

STEERING SYSTEM

SECTION ST

CONTENTS

STEERING COLUMN	ST-2	POWER STEERING GEAR AND LINKAGE ..	ST-14
STEERING WHEEL	ST-2	POWER STEERING OIL PUMP	ST-24
STEERING COLUMN	ST-2	SERVICE DATA AND	
STEERING LOCK	ST-4	SPECIFICATIONS (S.D.S.)	ST-28
MANUAL STEERING GEAR		GENERAL SPECIFICATIONS	ST-28
(Model : RP15L) AND LINKAGE	ST-4	INSPECTION AND ADJUSTMENT	ST-28
POWER STEERING SYSTEM		TIGHTENING TORQUE	ST-29
(Model : IPRP15L)	ST-9	TROUBLE DIAGNOSES AND	
DESCRIPTION	ST-9	CORRECTIONS	ST-30
POWER STEERING SYSTEM	ST-9	SPECIAL SERVICE TOOLS	ST-31

STEERING COLUMN

STEERING WHEEL

REMOVAL

1. Disconnect battery ground cable.
2. Remove horn pad.
3. Remove steering wheel nut.
4. Remove steering wheel using Steering Wheel Puller ST27180001.

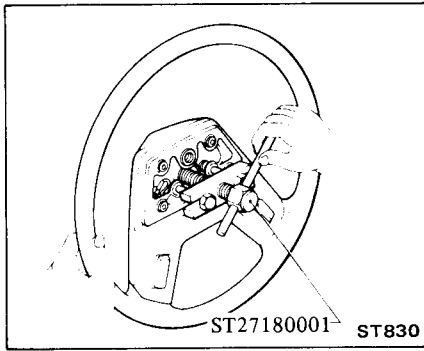

CAUTION:

Do not strike end of steering column shaft with a hammer. Striking shaft will damage bearing or column shaft.

Ⓣ : Steering wheel nut
 39 - 49 N·m
 (4.0 - 5.0 kg·m,
 29 - 36 ft·lb)

After installing steering wheel, turn it clockwise and counterclockwise, checking for catch or drag. Also check horn for operation.

INSTALLATION

Install steering wheel in the reverse order of removal. Observe the following instructions.

1. Apply grease to sliding portions.
2. Install steering wheel on column shaft in a straight ahead position after facing punch mark on the top of upper column shaft in that direction.

STEERING COLUMN

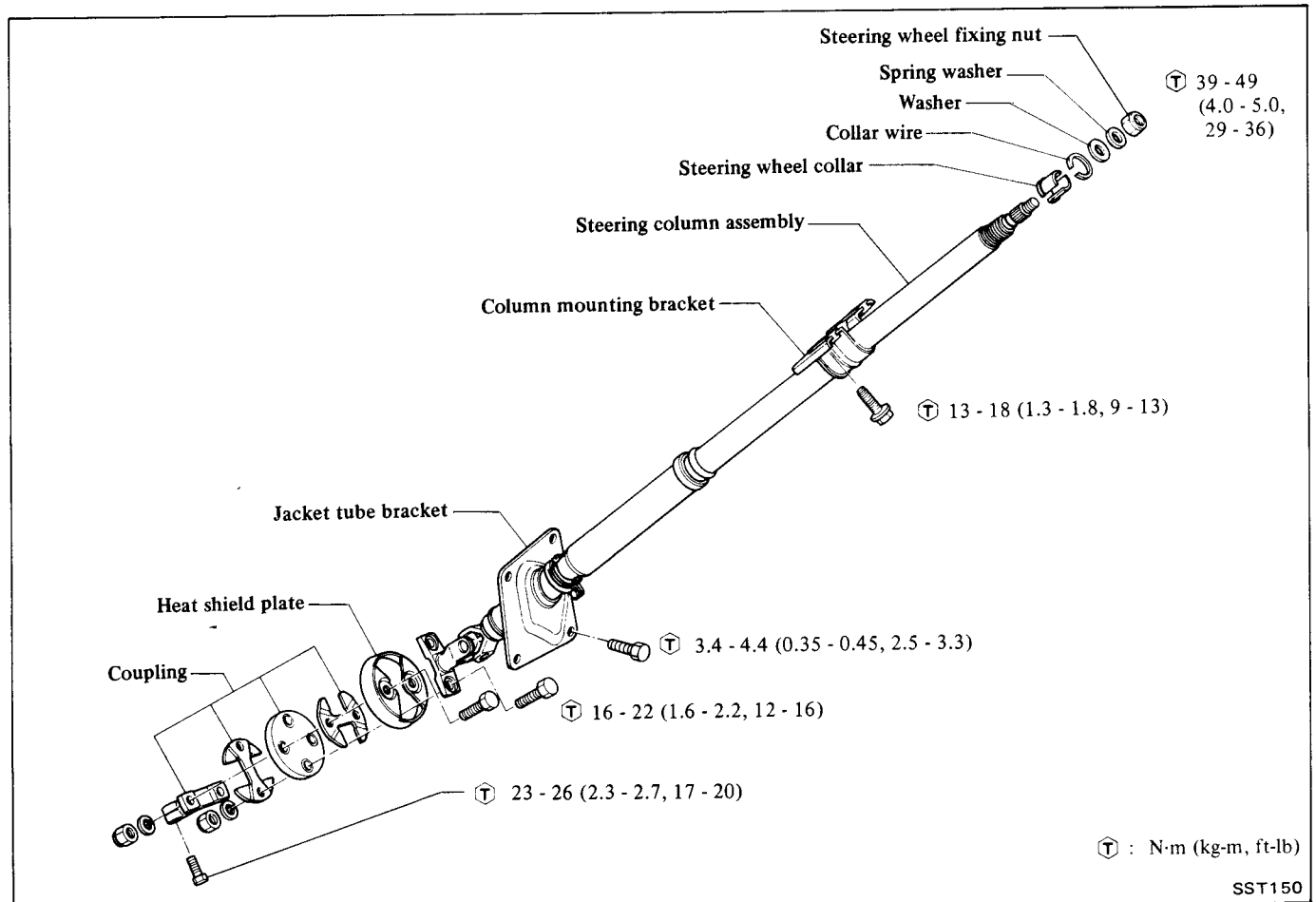

CAUTION:

- a. Never in any case should undue stress be applied to steering column in axial direction.
- b. When installing, do not apply bending force to steering column.

When a head-on collision is encountered, inspect steering system as follows:

The steering system is very important unit for driving. The collapsible type steering column should not be disassembled, and if necessary, replace it as an assembly.

REMOVAL

1. Remove bolt securing lower joint and rubber coupling.
2. Remove steering wheel. Refer to Steering Wheel.
3. Remove steering column shell covers.
4. Remove combination switch assembly.
5. Remove jacket tube bracket and jacket tube bracket cover from dash panel.
6. Remove column mounting bracket.

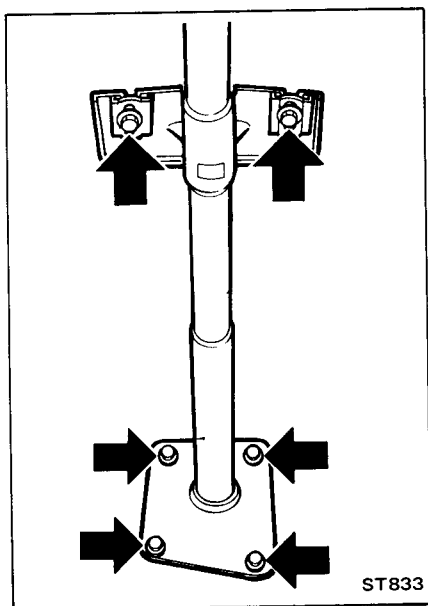

7. Draw out steering column assembly from the room side.

INSTALLATION

Install steering column in reverse order of removal.

1. Set wheels in a straight ahead position.
2. Fit steering column assembly into lower joint serration through dash panel.

Carefully install so that punch mark at top end of column shaft faces upward.

3. Tighten column mounting bracket temporarily.
4. Tighten lower joint securing bolts temporarily to support upper side of steering column assembly.
5. After sliding jacket tube bracket to dash panel, tighten bolts to retain it.

CAUTION:

- a. Make sure that undue stress is not applied to rubber coupling.
- b. To avoid damaging bolt or serrations, align groove in lower joint shaft with bolt hole in rubber coupling.

⊕ : Jacket tube bracket and cover to dash panel
 3.4 - 4.4 N·m
 (0.35 - 0.45 kg·m,
 2.5 - 3.3 ft·lb)

6. Tighten lower joint securing bolts and then tighten column mounting bracket securing bolts.

⊕ : Column mounting bracket
 13 - 18 N·m
 (1.3 - 1.8 kg·m,
 9 - 13 ft·lb)
 Lower joint to coupling
 23 - 26 N·m
 (2.3 - 2.7 kg·m,
 17 - 20 ft·lb)

7. Install steering wheel. Refer to Steering Wheel.
8. After installation, make sure that steering wheel turns smoothly.

INSPECTION

1. When steering wheel can not be rotated smoothly, check the steering

column for the following matters and replace faulty parts.

- (1) Check column bearings for damage or unevenness. If so, lubricate with recommended multi-purpose grease or replace with a new one as steering column assembly.
- (2) Check jacket tube for deformation or breakage, and replace if necessary.
- (3) Check column spring, and replace if damaged or weakened.

2. When the car comes into light collision, check the following parts and replace if necessary.

- (1) Jacket tube
 Measure dimension "L".
 When jacket tube is crushed, dimension "L" is reduced.

Column length "L":
 399.5 - 400.5 mm
 (15.73 - 15.77 in)

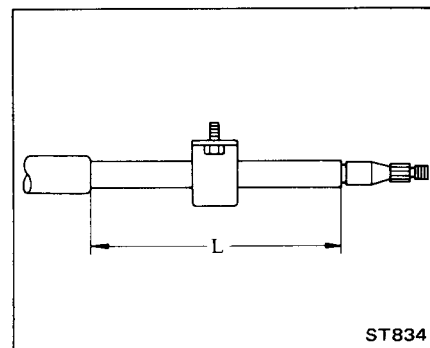

- (2) Column mounting bracket
 Make sure column mounting bracket touches block.
 Measure distance "B". Standard distance "B" is 0 mm (0 in). When jacket tube is crushed, distance "B" becomes larger.

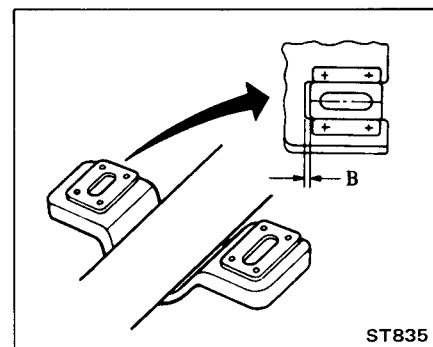

STEERING LOCK

To make steering lock system tamper-proof, self-shear type screws are used; their heads are sheared off upon installation so that steering lock system cannot be easily removed.

REMOVAL

1. Break self-shear type screws with a drill or other appropriate tool.
2. Remove screws and dismount steering lock.

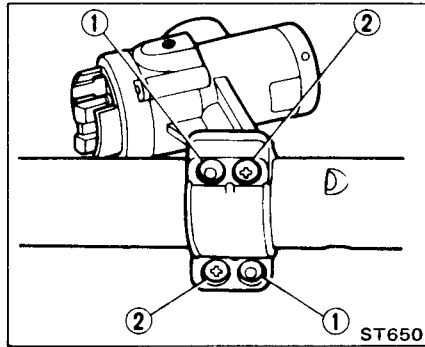

- 1 Self-shear type screw
- 2 Screw

INSTALLATION

1. Align steering lock hole in jacket tube with mating portion of steering lock.
2. Install self-shear type screws and cut off their heads.

MANUAL STEERING GEAR (Model : RP15L) AND LINKAGE

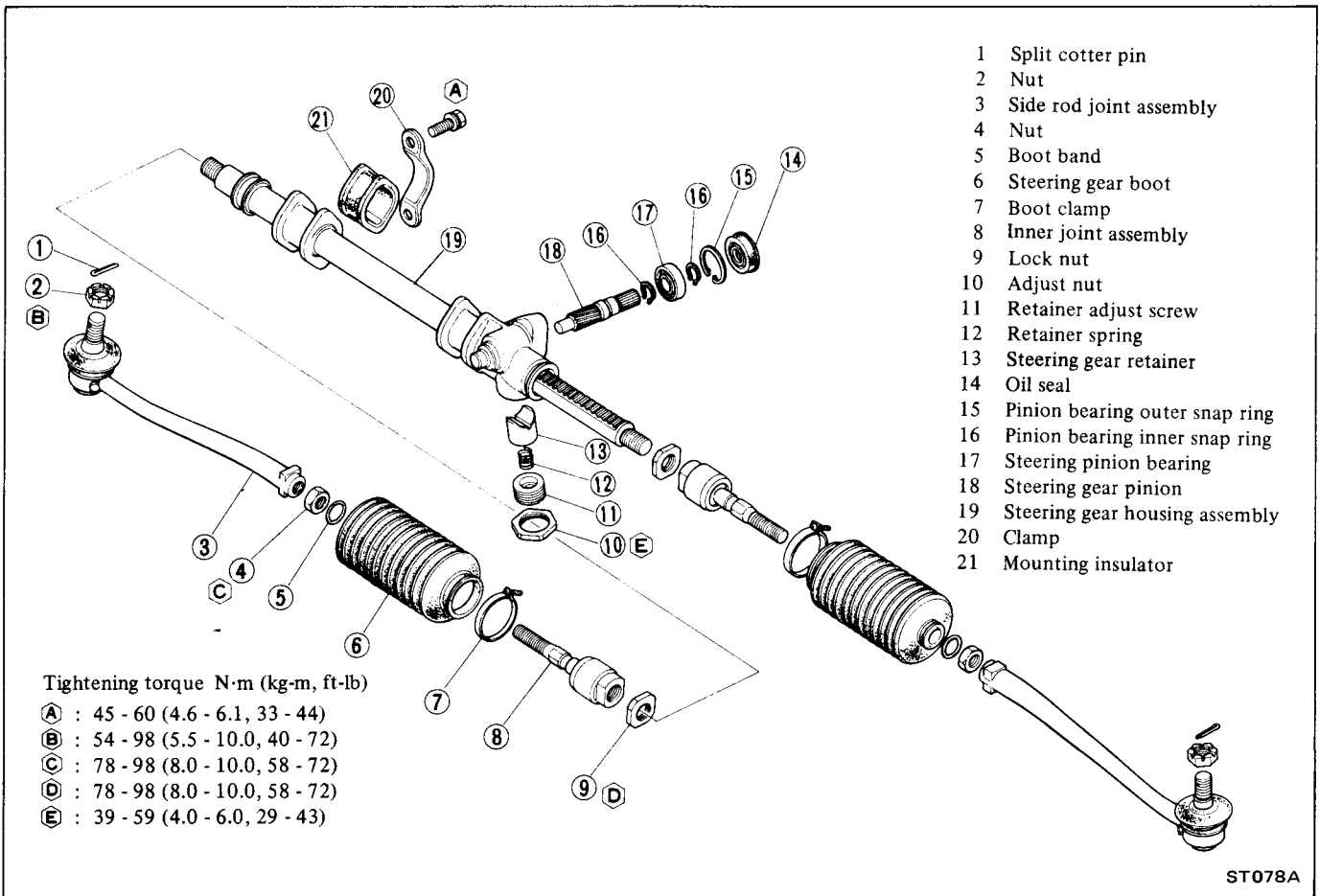

REMOVAL

1. Jack up front of car and support it with safety stand.
2. Loosen bolt securing lower joint shaft to rubber coupling.

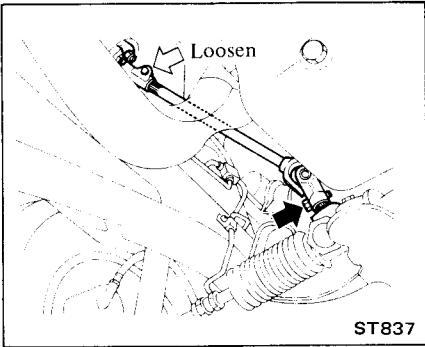

3. Disconnect bolt securing lower joint to steering pinion gear and then draw out lower joint from steering pinion gear.
4. Remove cotter pins and nuts fastening side rod ball studs.
5. To detach side rod ball studs from knuckle arms, insert Steering Ball Joint Remover HT72520000 between them and separate them.

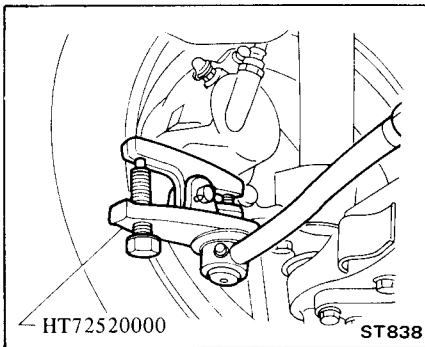

6. Remove bolts securing steering gear housing to suspension cross-member.

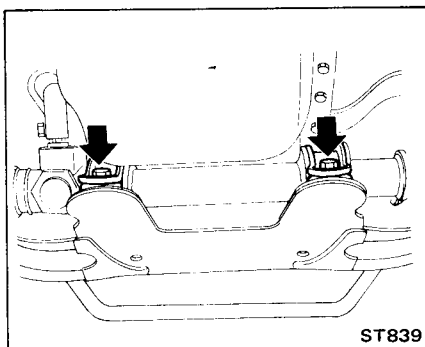

Before removal, loosen nuts mounting front engine mount, place a wooden block under oil pan and jack up so that front engine mount is raised by 10 to 15 mm (0.39 to 0.59 in).

7. Remove steering gear and linkage assembly from car.

INSTALLATION

Install steering gear and linkage in reverse order of removal.

Observe the following instructions:

- Ⓣ : Side rod to knuckle arm
 - 54 - 98 N-m
 - (5.5 - 10 kg-m,
 - 40 - 72 ft-lb)
- Gear housing clamp bolt
 - 45 - 60 N-m
 - (4.6 - 6.1 kg-m,
 - 33 - 44 ft-lb)
- Lower joint to pinion gear
 - 39 - 49 N-m
 - (4.0 - 5.0 kg-m,
 - 29 - 36 ft-lb)
- Lower joint to coupling
 - 23 - 26 N-m
 - (2.3 - 2.7 kg-m,
 - 17 - 20 ft-lb)

Check wheel alignment, and if necessary adjust.

Refer to Section MA.

DISASSEMBLY

1. Clamp steering gear and linkage assembly in a vise using patches on steering gear housing to prevent scarring.
2. Remove boot clamps from steering gear boots. (Both left and right)

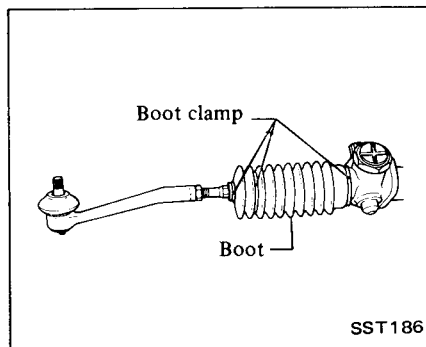

3. Loosen inner joint lock nut.
4. Remove side rod assembly from rack.

CAUTION:

Do not disassemble inner joint assembly and side rod socket assembly.

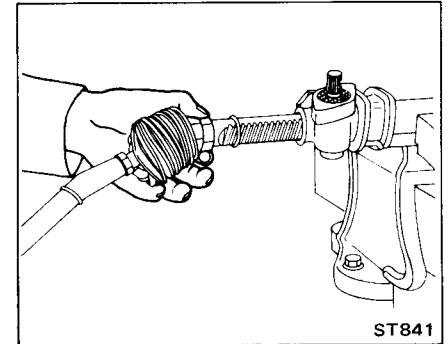

5. Loosen adjust lock nut and remove retainer adjust screw. Then take retainer spring and steering gear retainer out.

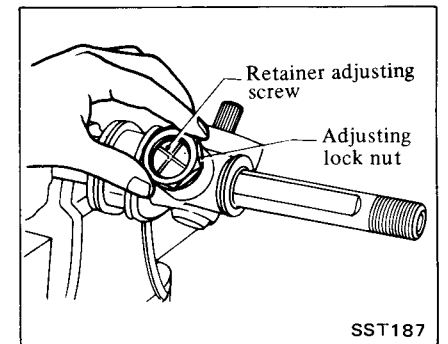

6. Remove oil seal from gear housing.

Oil seal must not be reused.

7. Pry off snap ring from gear housing.
8. Draw steering pinion assembly out.
9. Draw rack out from gear housing.

Pinion gear

1. Pry off snap ring securing pinion bearing from the side of bearing.

2. Press out bearing from pinion shaft.

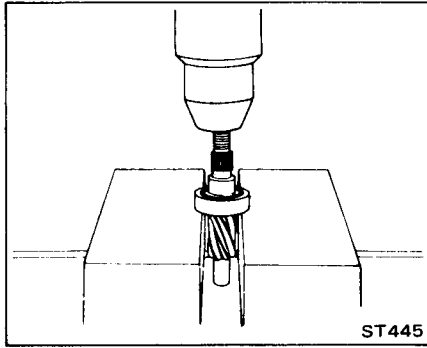

INSPECTION

Thoroughly clean all parts in cleaning solvent, and blow dry with compressed air, if available.

Rack

Thoroughly examine rack gear. If rack gear is worn, replace.

Fractures, hollows, or roughness in surfaces of rack indicate unserviceability.

Pinion

Thoroughly examine pinion gear. If pinion gear is damaged, cracked or worn, replace.

Side rod outer ball joint

Ball joint is assembled at factory and cannot be disassembled.

1. Check ball joint for play. If ball stud is worn and play in axial direction is excessive or joint is hard to swing, replace as a complete unit.

Side rod outer ball joint:

Swinging torque:

0.3 - 4.9 N·m
 (3 - 50 kg-cm,
 2.6 - 43.4 in-lb)

2. Check condition of dust cover. If it is cracked excessively, replace ball joint.

Side rod inner ball joint

Ball joint is assembled at factory and cannot be disassembled.

1. Check ball joint for play. If ball stud is worn and play in axial direction is excessive or joint is hard to swing, replace as a complete unit.

Side rod inner ball joint:

Swinging torque:

0 - 4.9 N·m
 (0 - 50 kg-cm,
 0 - 43 in-lb)

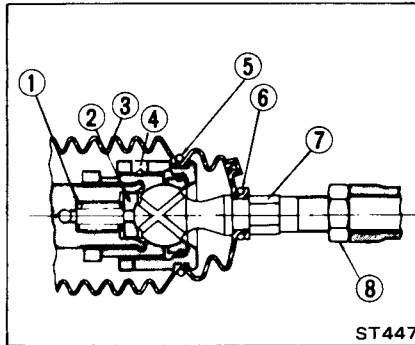

- | | |
|-------------------|--------------------|
| 1 Side rod spring | 5 Dust cover clamp |
| 2 Spring seat | 6 Boot clamp |
| 3 Boot | 7 Side rod ball |
| 4 Welded | 8 Stopper nut |

2. Check condition of boot. If it is cracked excessively, replace it.

Pinion bearing

Inspect bearings to see that they roll freely and are free from cracked, pitted, or worn balls, rollers and races. Replace if necessary.

Oil seal

Replace oil seal every disassembly even if it appears serviceable.

ASSEMBLY AND ADJUSTMENT

Assemble steering gear in reverse order of disassembly. Observe following instructions.

Rack and pinion

1. Install inner snap ring (2) onto pinion gear.

Inner snap ring thickness:

1.19 - 1.24 mm
 (0.0469 - 0.0488 in)

2. Press bearing onto pinion gear.

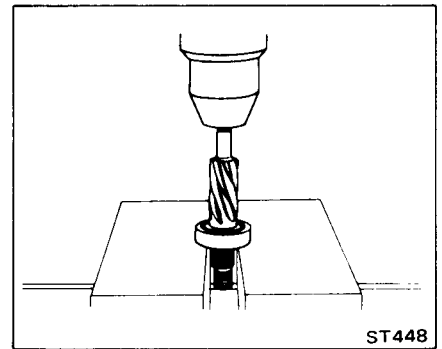

3. Install outer snap ring (1).

Snap ring (1) should be of such thickness that axial play is less than 0.1 mm (0.004 in).

To ensure proper axial play, select snap ring of proper thickness.

Pinion bearing inner snap ring:

Refer to Service Data and Specifications.

Snap rings should be fitted to grooves correctly.

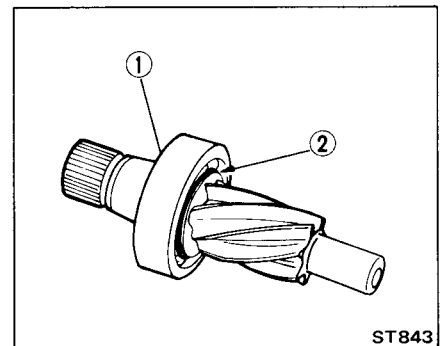

4. Clamp steering gear housing in a vise.

5. Sparingly apply recommended multi-purpose grease to toothed faces and friction surfaces of rack.

6. Insert rack gear from gear housing side.

Pay attention to direction of rack teeth.

7. Properly mesh pinion with rack, and insert pinion assembly into groove in pinion serration part facing upward.

8. Make sure that rack protrudes by the same amount from both ends of housing.

Standard length "L" (both sides)
L: 89.4 mm (3.520 in)

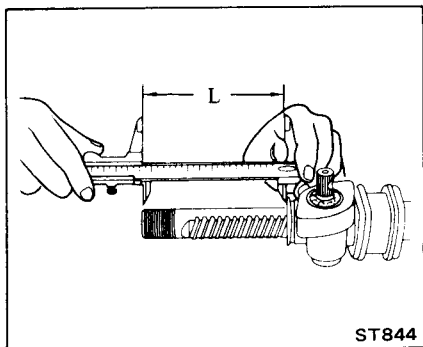

Ⓣ : 39 - 59 N·m
(4 - 6 kg·m,
29 - 43 ft·lb)

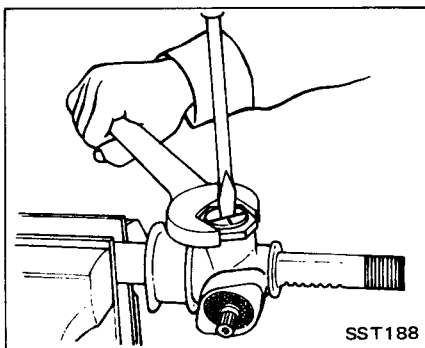

Both parts should move smoothly
over their entire travel.

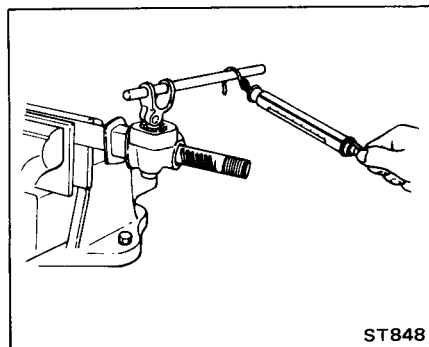

9. Secure pinion bearing to gear housing with snap ring.

Snap ring should be of such thickness that axial play is less than 0.1 mm (0.004 in).

Pinion bearing outer snap ring:
Refer to Service Data and Specifications.

10. Fit grease seal.

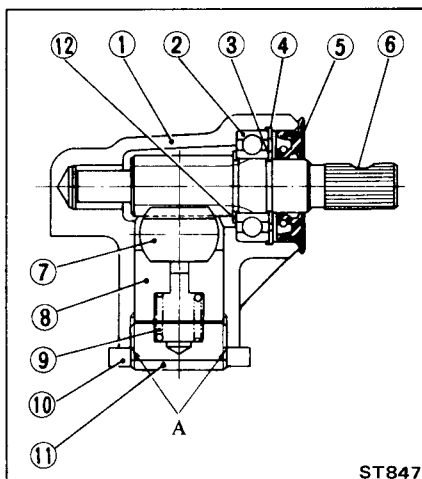
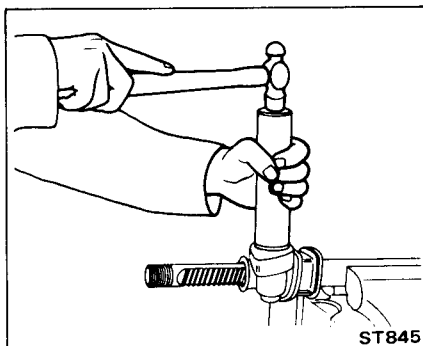

- 1 Steering gear housing
- 2 Steering pinion bearing
- 3 Snap ring
- 4 Pinion bearing outer snap ring
- 5 Oil seal
- 6 Steering gear pinion
- 7 Steering rack gear
- 8 Steering gear retainer
- 9 Retainer spring
- 10 Lock nut
- 11 Retainer adjust screw
- 12 Snapping

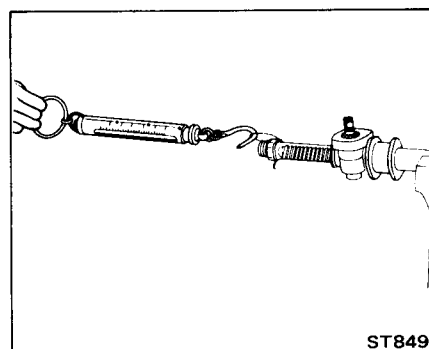

Side rod and gear boot

1. Fit boot and small clamp on side rod assembly.
2. Thread lock nut and lock nut over the threaded portion of rack.
3. Apply an adequate amount of recommended multi-purpose grease to the sliding surfaces of side rod inner joint and spring seat.
4. Fit side rod assembly to rack end together with inner spring and spring seat.

Pack sealing lips with multi-purpose grease.

11. Make sure that pinion assembly rotates smoothly.

12. Apply an adequate amount of recommended multi-purpose grease to steering gear retainer.

13. Insert gear retainer and retainer spring into housing. Turn retainer adjusting screw in, and install adjusting lock nut.

14. Fully tighten adjusting screw and then back it off 20 to 25 degrees.

15. Apply suitable liquid sealant around lock nut at "A" and tighten lock nut.

16. Upon completion of gear assembly measure the torque required to keep pinion and rack in motion. Re-adjust retainer adjusting screw as necessary to obtain proper torque.

Pinion (turning torque):
Less than 2.0 N·m
(20 kg·cm, 17 in·lb)

Rack (force to pull at neutral position):
Less than 98 N
(10 kg, 22 lb)

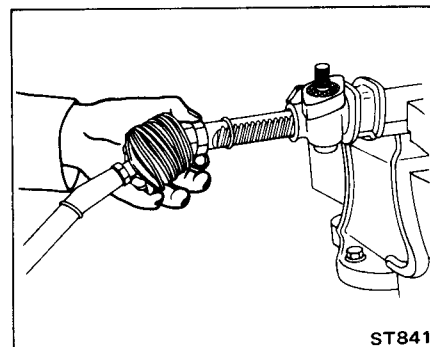

a. Make sure that boot is carefully positioned toward the ball stud end.

b. Side rod assembly for the left side has an L-mark. (No mark is used for the right side.)

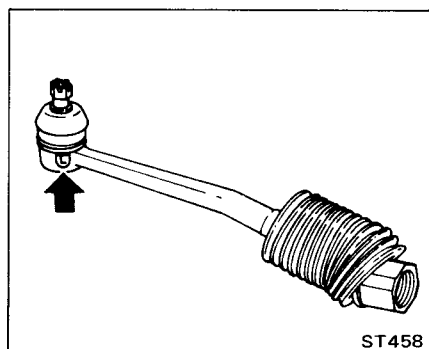

Axial play:
0 - 0.05 mm
(0 - 0.0020 in)

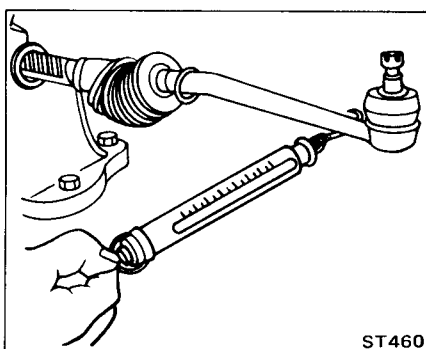

9. Install boot to gear housing, then tighten inside boot clamp securely.

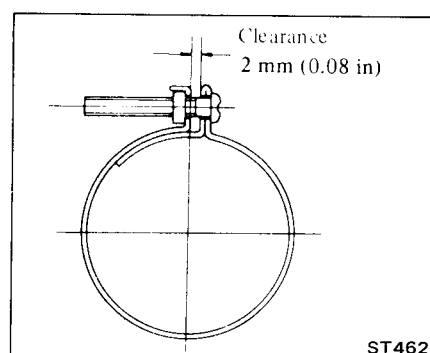

5. Screw inner socket portion until ball seat reaches the rack end, and then tighten lock nut securely.

⊕ : 78 - 98 N·m
(8 - 10 kg·m,
58 - 72 ft·lb)

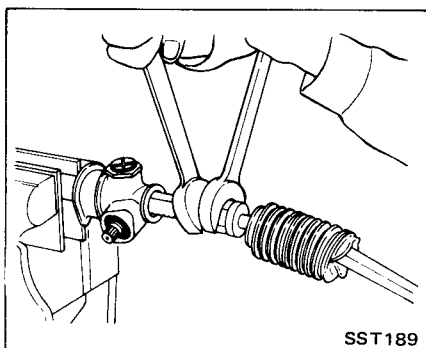

7. Measure rack stroke.

Rack stroke "L" (both sides):
66.4 mm (2.614 in)

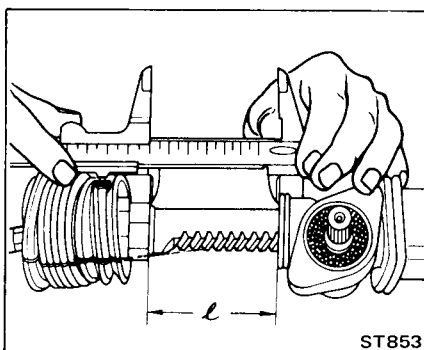

Boot should be neither too inflated nor too elongated.

10. Adjust the side rod length both left and right, and tighten steering stopper nuts.

⊕ : 78 - 98 N·m
(8 - 10 kg·m,
58 - 72 ft·lb)
Side rod length "L"
29.5 mm (1.161 in)

6. Upon completion of side rod assembly, measure swinging torque and axial play of inner ball joint.

Swinging torque:
0 - 4.9 N·m
(0 - 50 kg·cm,
0 - 43 in·lb)

8. Fit large boot clamp at inner socket, install a grease nipple at both ends of rack, and apply recommended multi-purpose grease to each joint.

Lubrication of the rack ends is made so that a small quantity of new grease appears at the boot grease outlet hole.

Do not apply an excessive amount of grease.

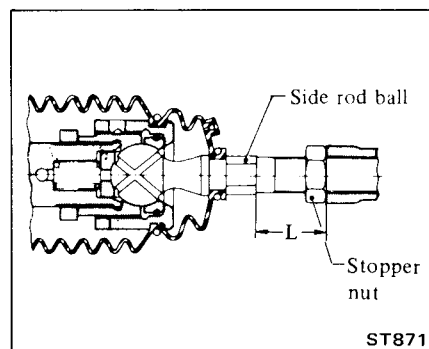

POWER STEERING SYSTEM (Model : IPRP15L)

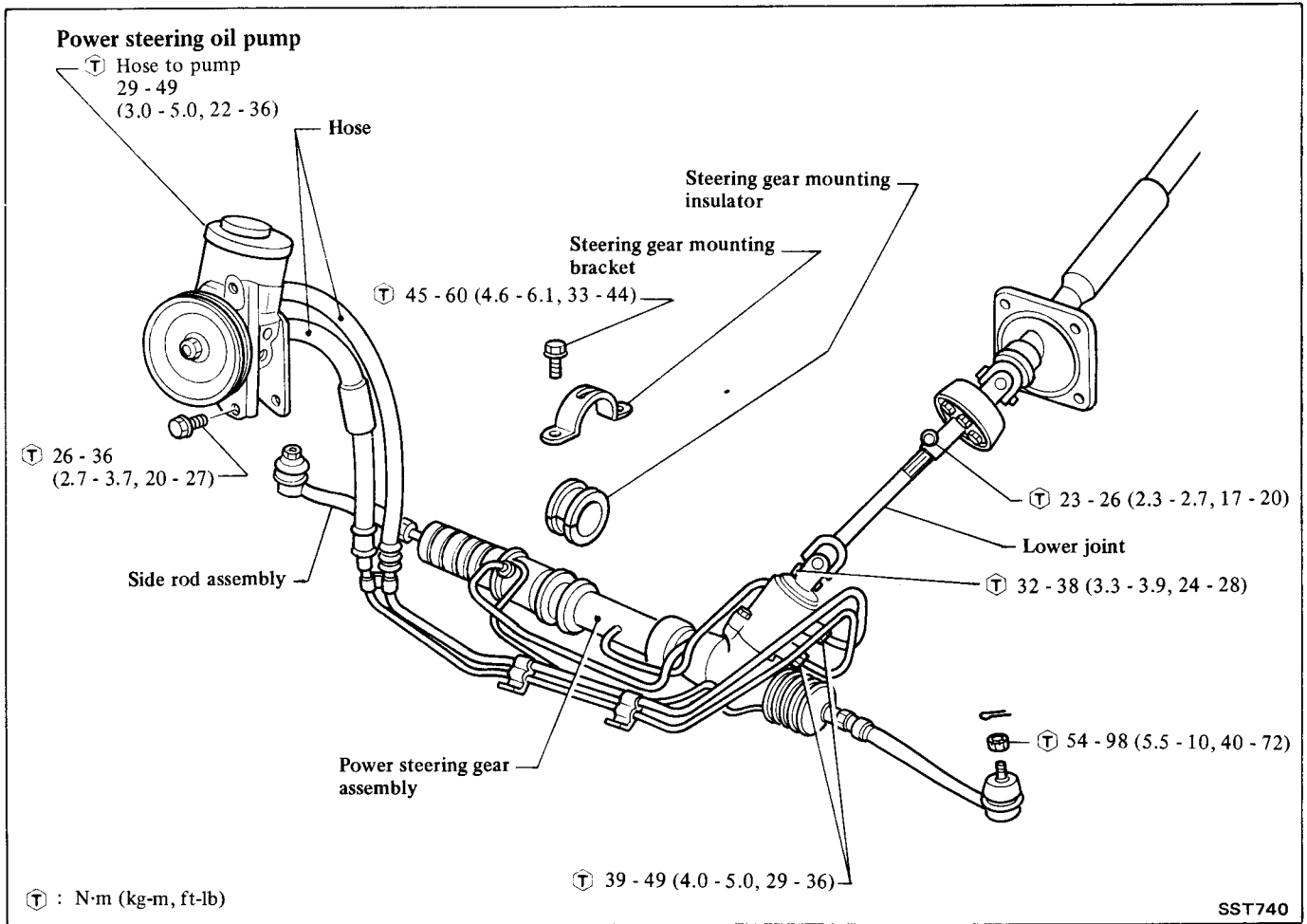

DESCRIPTION

POWER STEERING SYSTEM

The power steering gear is licensed by ZF company in West Germany.

The major components are as follows:

- Power steering pump
- Power steering gear and linkage
- Hydraulic piping

POWER STEERING GEAR AND OIL PUMP

The integral power steering gear and oil pump are an accurate hydraulic pressure mechanism.

Only the sealing parts can be replaced. The remaining parts must be replaced as an assembly.

CAUTION:

- a. The parts which can be disassembled are strictly limited, and never disassemble other parts than the specified ones.
- b. Disassembly of integral power steering gear should be performed in a place as clean as possible.
- c. Hands should be cleaned before disassembly.
- d. Do not use a rag. Be sure to use nylon or paper cloth.
- e. Be sure to follow procedures and cautions indicated in the Service Manual.

POWER STEERING SYSTEM

INSPECTION

Fluid level

1. Check the fluid level in reservoir

by observing the dipstick when the fluid is cold. Add fluid as necessary to bring the level into the proper range on dipstick.

CAUTION:
Do not overfill.

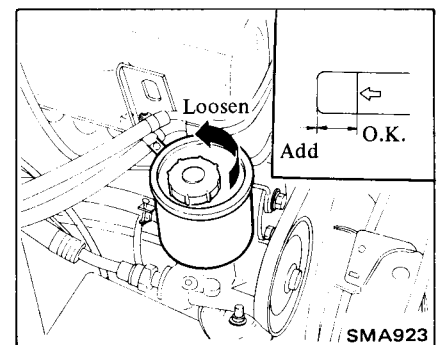

2. Check fluid level and leakage.

Recommended fluid is Automatic Transmission Fluid "Dexron Type".

Refer to Section MA for "Recommended Lubricant".

Fluid capacity (With pump, each hose and steering gear assembly):

Approximately: 1.1 ℓ
(1 - 1/8 US qt, 1 Imp qt)

Pump belt adjustment

Adjust power steering oil pump belt tension.

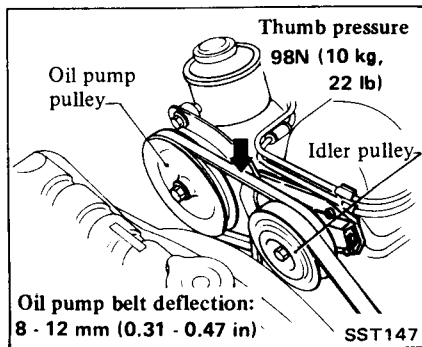

Check fluid leakage

1. Run engine at idle speed or 1,000 rpm.

Make sure temperature of fluid in pump rises to 60 to 80°C (140 to 176°F).

2. Turn steering wheel to right-to-left several times.

3. Hold steering wheel at each "lock" position for five seconds and carefully check the following points for fluid leakage.

- Pinion housing
- Rear housing and rear cover
- Rack end (Both sides)
- Cylinder
- If fluid leakage at connectors is noticed, once loosen flare nut and then retighten.

CAUTION:

Do not hold steering wheel at lock position for more than fifteen seconds at a time.

Hydraulic system check

To determine whether problem is in steering gear or power steering pump, measure operating pressure.

Before conducting hydraulic system test, carefully check belt tension and condition of driving pulley.

Tires must be inflated to normal pressure.

1. Check fluid level and fluid leakage, adding fluid if necessary.

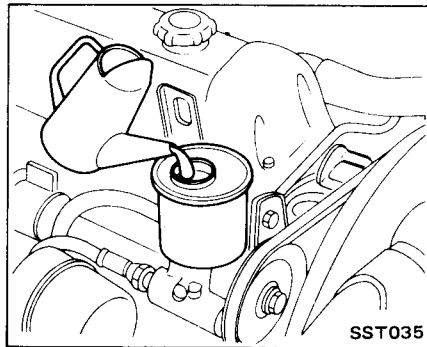

2. Run engine.

Make sure temperature of fluid in pump rises to 60 to 80°C (140 to 176°F).

3. Stop engine.

4. Set Tool. And bleed air.

- Gauge must be between shut-off valve and power steering pump.

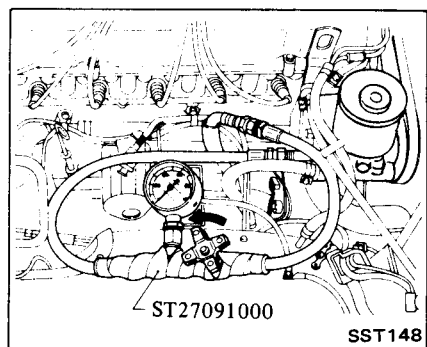
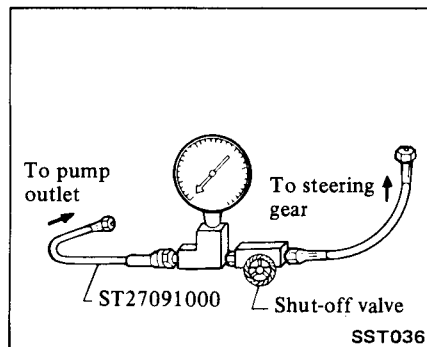

5. Open shut-off valve.

6. Check fluid level, adding fluid if necessary.

7. Run engine at idle for 3 to 5 seconds.

8. Stop engine and check fluid level, adding fluid if necessary.

9. Run engine and check fluid level again, adding fluid if necessary.

10. Turn steering wheel fully in left or right until fluid reaches operating temperature.

- Be sure that all connections are tight.
- Expel any air from system.

11. Check pressure with steering wheel fully turned in left and right.

CAUTION:

Do not hold steering wheel at lock position for more than fifteen seconds, as this would abnormally increase fluid temperature and cause undue gear and pump wear.

Pressure should be as follows:

Normal pressure:

6,571 - 7,748 kPa

(67 - 79 kg/cm², 953 - 1,123 psi)

at idling

12. If oil pressure is abnormal, slowly close shut-off valve and check oil pressure to determine which part is faulty, as follows:

Pressure	Faulty part
Normal	Gear
Abnormal	Pump

CAUTION:

Do not close shut-off valve for more than fifteen seconds, as this would abnormally increase lubricant temperature and cause undue pump wear.

13. Replace any part that is faulty.

CAUTION:

The power steering system consists primarily of an accurate hydraulic pressure unit.

Any abnormality in one of this unit's parts will cause the other part(s) to malfunction, or the oil to deteriorate. Whenever faulty parts must be replaced, oil should be discarded and all other parts should be cleaned.

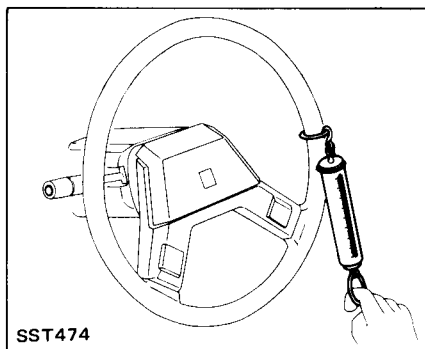

3. Disconnect flare nut at steering gear and drain fluid.

Be careful not to damage flare nut.

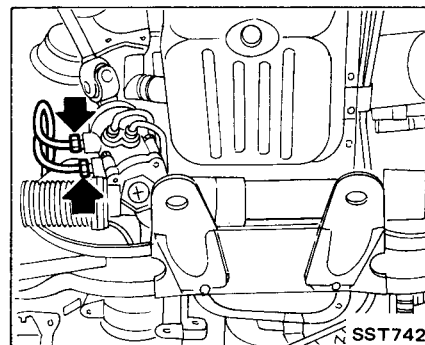

14. Open shut-off valve, pour fresh oil into and bleed air from power steering system, as outlined in the "Bleeding Hydraulic System" section.

15. Repeat steps 10 through 14 above until oil pressure is normal.

After checking hydraulic system, remove Tool and add fluid as necessary, then completely bleed air out of system.

4. Remove cotter pins and nuts fastening side rod ball studs, and detach side rod ball studs from knuckle arms with Tool.

REMOVAL

Power steering gear and linkage

CAUTION

- Whenever disconnecting hydraulic lines, cover openings to prevent foreign matter from entering.
- When installing or carrying power steering gear, be sure to hold gear, and not tube. When tube is held, it may be deformed or fluid will leak out from connector.

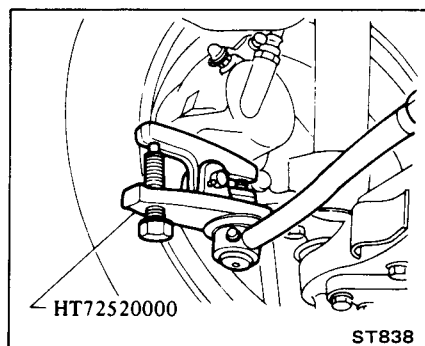

Steering wheel turning force check

1. Park car on a level, dry surface and set parking brake firmly.
2. Bring power steering fluid up to adequate operating temperature. [Approximately 60 to 80°C (140 to 176°F)].

- Fluid temperature can be warmed up more easily by idling engine and at the same time turning steering wheel from left to right for about two minutes. Alternatively, drive car several miles.
- Tires must be inflated to normal pressure.

3. Check steering wheel turning force when steering wheel has been turned 360° from straight-ahead position.

Steering wheel turning force:
 Less than 24.5 - 29.4 N (2.5 - 3.0 kg, 5.5 - 6.6 lb)

1. Jack up front of car and support it with safety stand.
2. Disconnect hose clamp fixing bolt.

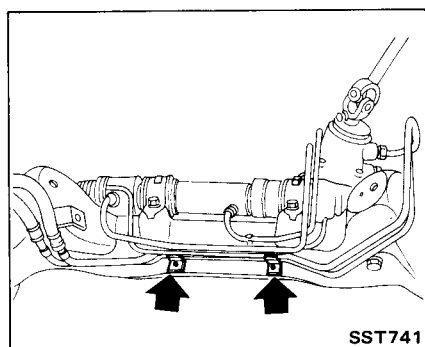

5. Loosen bolt securing lower joint to rubber coupling. Disconnect bolt securing lower joint to pinion gear. And then draw out lower joint from pinion gear.

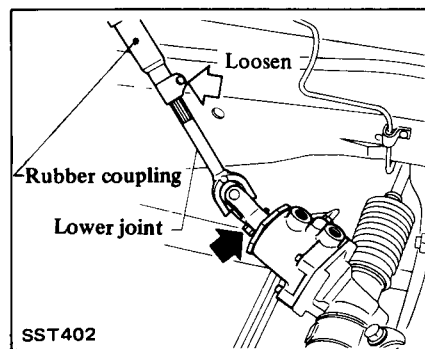

6. Remove nuts that secure front engine mounting insulator to front suspension crossmember.

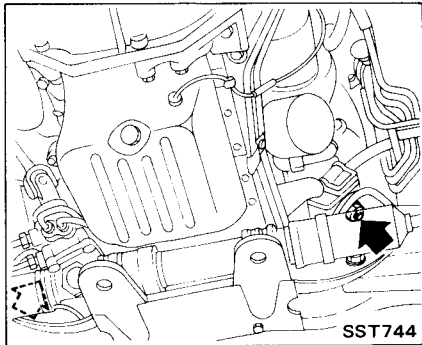

7. Refer to the ER section and remove engine hood. Lift engine until front engine mounting insulator is slightly away from front suspension crossmember.

8. Loosen (not remove) steering gear mounting bolts.

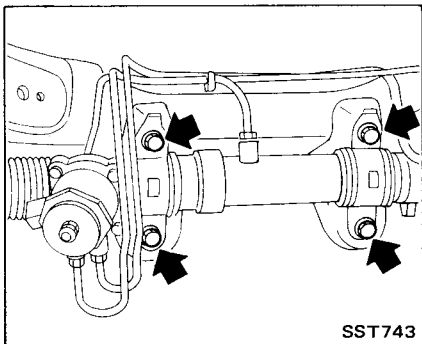

9. Lightly support front suspension crossmember with a garage jack, remove bolts and then lower jack.

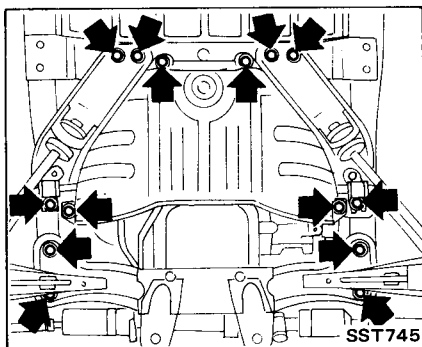

10. Remove bolt securing steering gear housing to suspension crossmember. And then remove steering gear and linkage assembly from car.

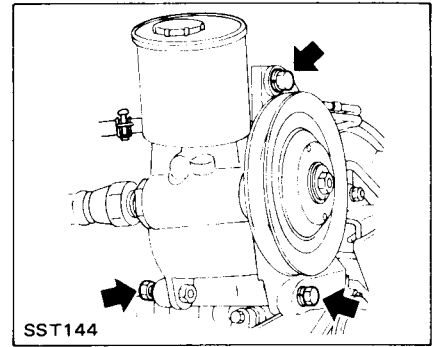

Oil pump

CAUTION:
Whenever disconnecting hydraulic lines, cover openings to prevent foreign matter from entering.

1. Loosen power steering pump pulley lock nut.
2. Turn adjusting bolt counterclockwise to loosen pump belt.

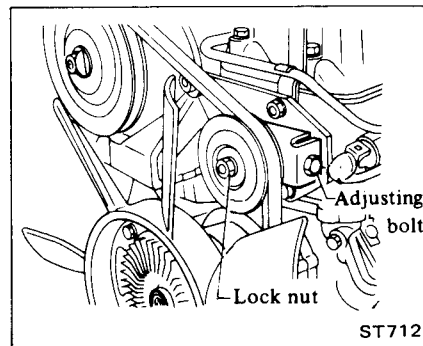

3. Remove power steering pump belt.
4. Disconnect pressure hose flare nut at power steering pump, and drain fluid. Then remove return hose clamp.

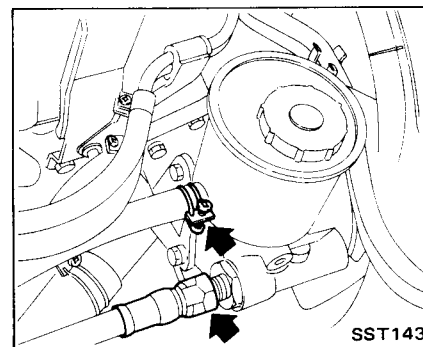

5. Remove power steering pump assembly.

Hose

1. Remove bolts.

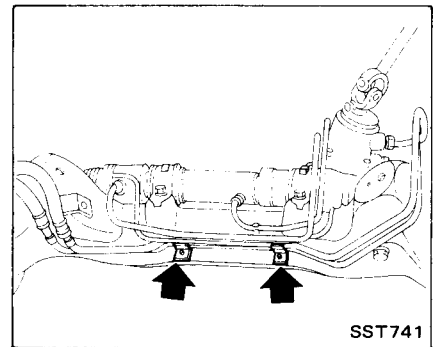

2. Disconnect flare nut at steering gear and drain fluid.

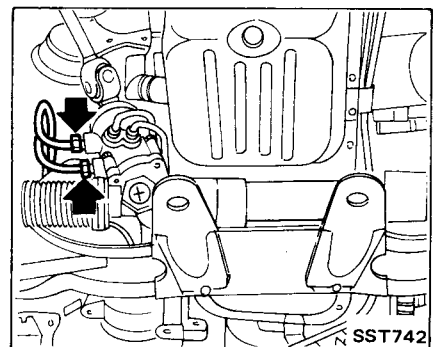

3. Disconnect hose from oil pump and remove it from car.

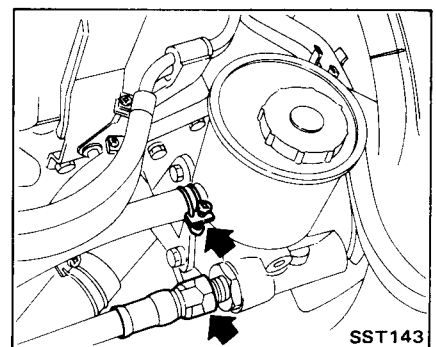

INSTALLATION AND ADJUSTMENT

Power steering gear and linkage

Install steering gear and linkage in the reverse order of removal.

Install lower joint on steering gear as shown, and then tighten steering gear mounting bolts.

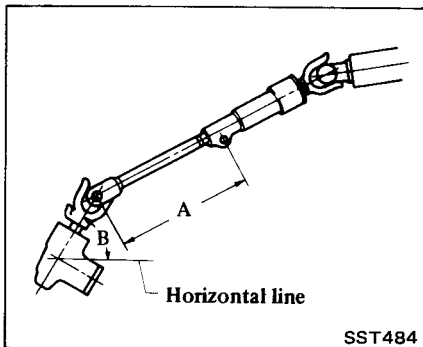

"A" dimension:
197.3 mm (7.77 in)
"B" angle: 57.07°

Ⓣ : Side rod to knuckle arm

54 - 98 N·m
(5.5 - 10 kg·m,
40 - 72 ft·lb)

Gear housing clamp bolt

45 - 60 N·m
(4.6 - 6.1 kg·m,
33 - 44 ft·lb)

Lower joint to pinion gear

32 - 38 N·m
(3.3 - 3.9 kg·m,
24 - 28 ft·lb)

Lower joint to rubber coupling

23 - 26 N·m
(2.3 - 2.7 kg·m,
17 - 20 ft·lb)

Front suspension crossmember to body

69 - 88 N·m
(7.0 - 9.0 kg·m,
51 - 65 ft·lb)

Tension rod bracket to body

31 - 42 N·m
(3.2 - 4.3 kg·m,
23 - 31 ft·lb)

Front suspension crossmember to front engine mounting insulator

31 - 42 N·m
(3.2 - 4.3 kg·m,
23 - 31 ft·lb)

Hose to power steering gear

39 - 49 N·m
(4.0 - 5.0 kg·m,
29 - 36 ft·lb)

Check wheel alignment, and if necessary adjust.

Refer to Section MA.

After installation is completed, fill fluid and bleed system.

Oil pump

Install power steering pump and hoses in the reverse order of removal.

Ⓣ : Pressure hose to pump

29 - 49 N·m
(3.0 - 5.0 kg·m,
22 - 36 ft·lb)

Pump mounting bolt

26 - 36 N·m
(2.7 - 3.7 kg·m,
20 - 27 ft·lb)

After installation is completed, fill fluid and bleed system.

Bleeding hydraulic system

1. Raise front end of car until wheels clear ground.
2. Quickly turn steering wheel all the way to right and left ten times and lightly touch wheel stoppers.
3. Check fluid level, adding fluid if necessary.

4. Run engine. Make sure temperature of fluid in pump rises to 60 to 80°C (140 to 176°F) with a temperature indicator.

5. Stop engine, adding fluid if necessary.

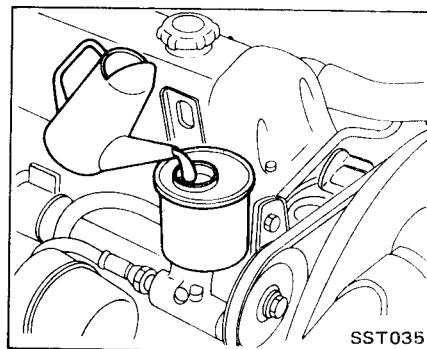

6. Run engine for 3 to 5 seconds.
7. Stop engine, adding fluid if necessary.
8. Quickly turn steering wheel all the way to right and left ten times and lightly touch wheel stoppers.
9. Check fluid level, adding fluid if necessary.
10. Start engine at idle.

Repeat steps 6 through 10 until air will be bled from pump.

11. If air cannot be bled completely in steps 1 through 10, proceed as follows:

Turn steering wheel to right and left from lock to lock five to ten times. Carefully check fluid leakage with steering wheel held at each lock position for five seconds.

CAUTION:

Do not hold steering wheel at lock position for more than fifteen seconds at a time.

POWER STEERING GEAR AND LINKAGE

DISASSEMBLY

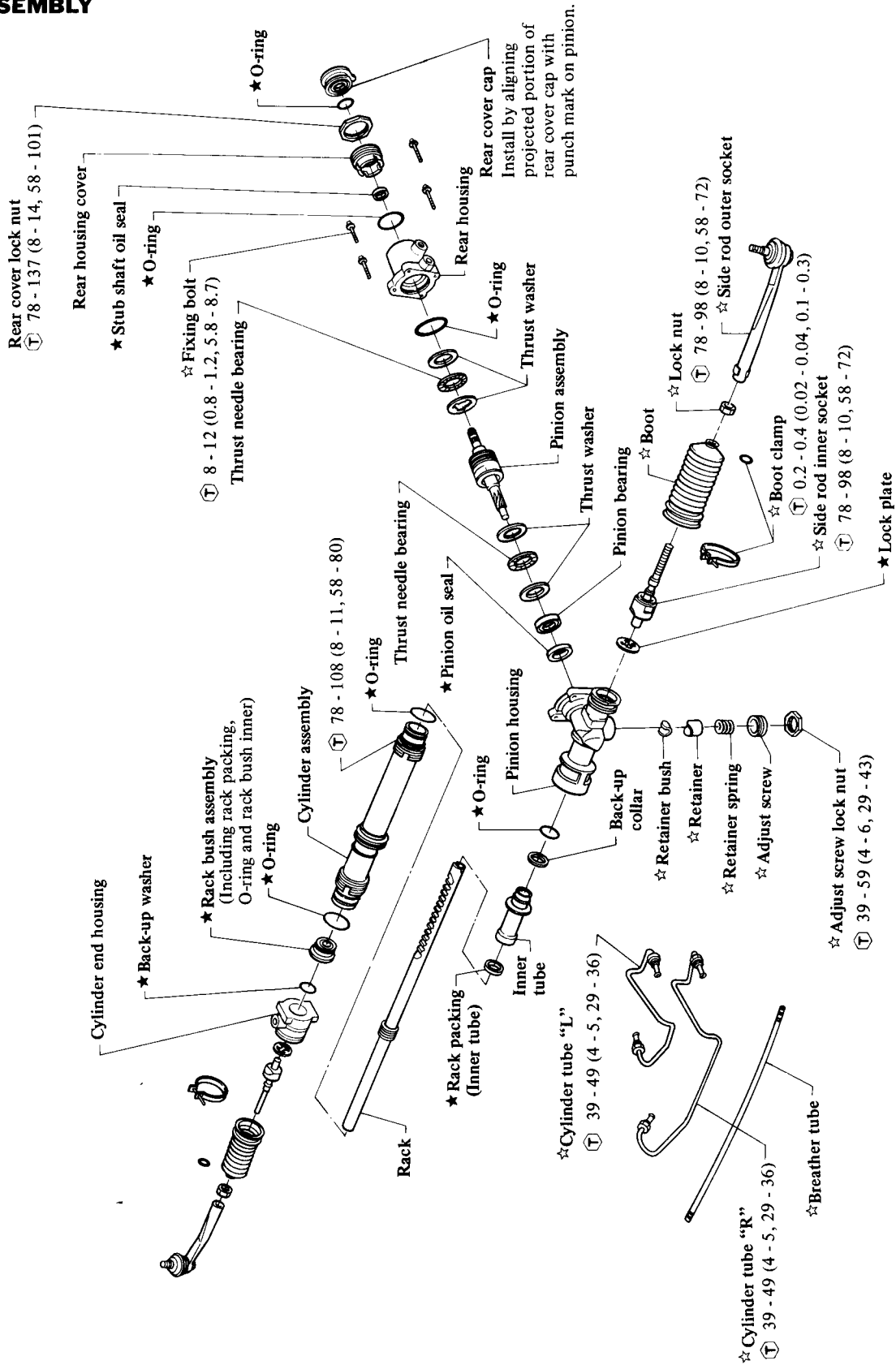

(T) : N·m (kg·m, ft·lb)
 ☆ or ☆ : are available for service replacement.
 ★ : always replace when disassembled.

CAUTION:

When disassembling and reassembling, do not allow any foreign matter to enter or contact parts.

Measuring pinion rotating torque and rack starting force

Prior to disassembling, measure pinion rotating torque and rack starting force. If they are not within specifications, adjust retainer adjust screw. If adjustments cannot be made properly, replace steering gear assembly.

Install steering gear on Tool KV48102100 in a vice.

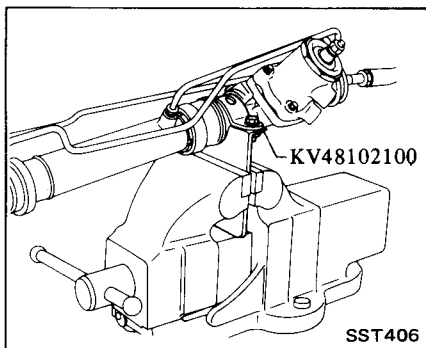

Before measuring, be sure to disconnect cylinder tube and drain fluid.

a. Pinion rotating torque

Less than 0.9 N·m (9 kg·cm, 7.8 in·lb) on average and less than 1.5 N·m (15 kg·cm, 13 in·lb) at maximum.

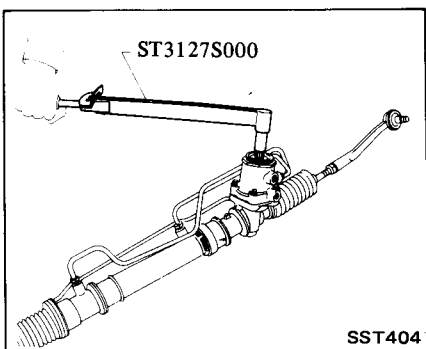

- Stub shaft can be turned by wrapping vinyl tape around serration area of stub shaft and fitting socket wrench.

b. Rack starting force

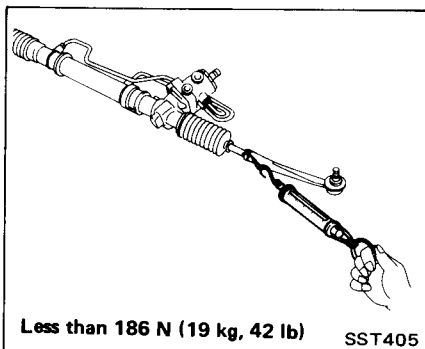

Side rod and breather tube

1. Install steering gear on Tool KV48102100 in a vice.
2. Remove boot clamp and then remove breather tube. (Both left and right)

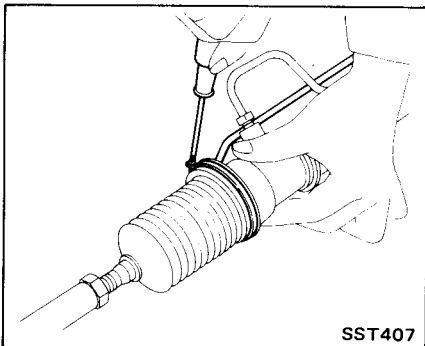

3. Flatten lock plate.

Always replace lock plate when disassembled.

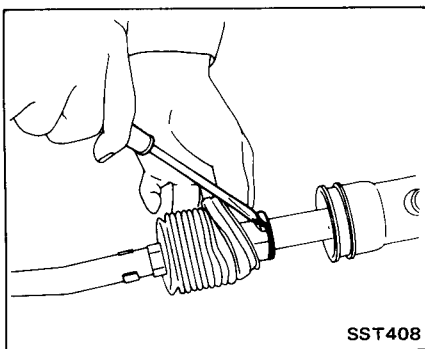

4. Disconnect side rod inner socket and remove side rod assembly from steering gear assembly.

Use a wrench of approximately 6 mm (0.24 in) in thickness which can be placed in the thickness across the flats of the rack.

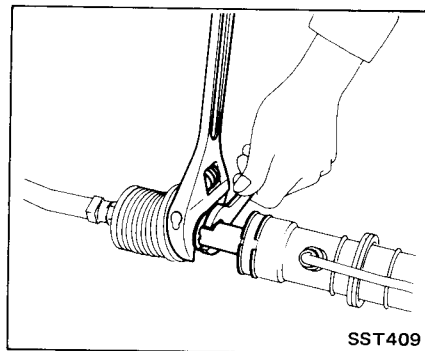

5. Remove side rod inner socket from side rod outer socket.

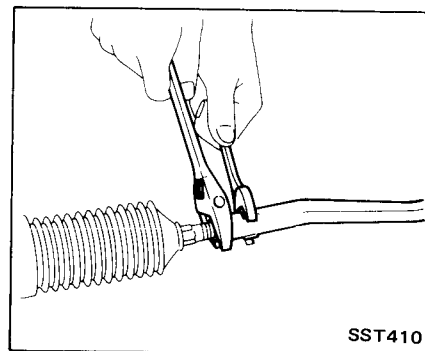

CAUTION:

Do not disassemble inner socket assembly and outer socket assembly.

Cylinder tubes

1. Install steering gear on Tool KV48102100 in a vice.
2. On cylinder tube "L", first disconnect flare nut at cylinder side and then the other one at pinion housing side.

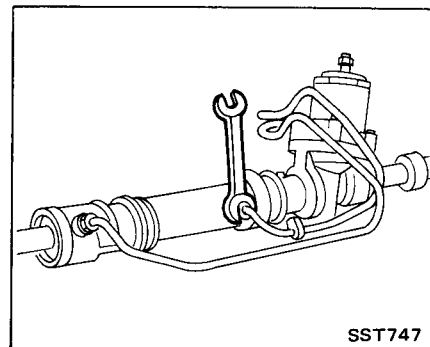

3. Remove cylinder tube "R" in the same way.

Retainer

1. Install steering gear on Tool KV48102100 in a vice.
2. Loosen adjust screw lock nut and then remove retainer adjust screw. Take retainer out.

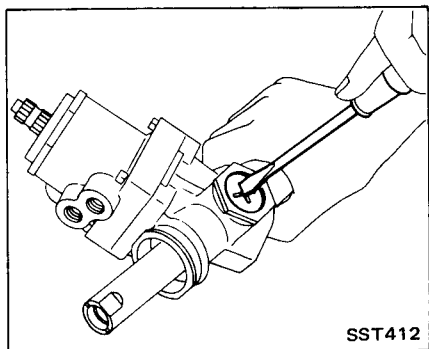

Stub shaft oil seal

1. Install steering gear on Tool KV48102100 in a vice.
2. Remove retainer.

Refer to Retainer for disassembly.

3. Remove rear cover cap and loosen rear cover lock nut two or three pitches using Tool.

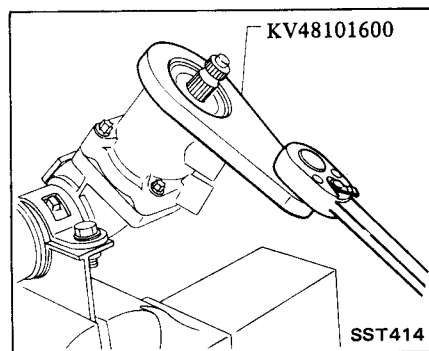

4. Remove rear housing cover using Tool.

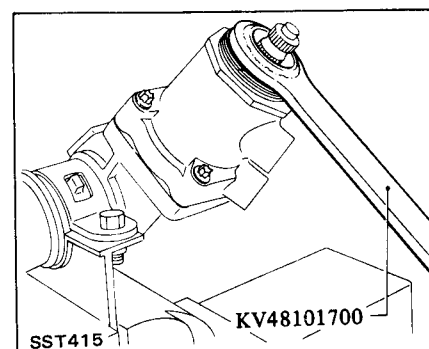

5. Remove rear cover O-ring and discard.

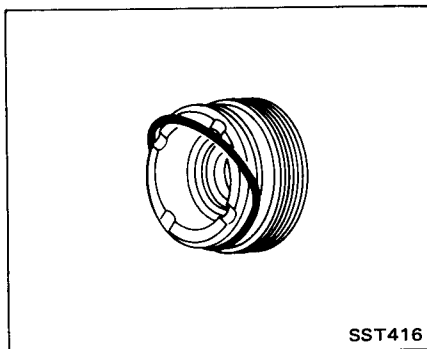

6. Remove stub shaft oil seal using suitable tool and discard.

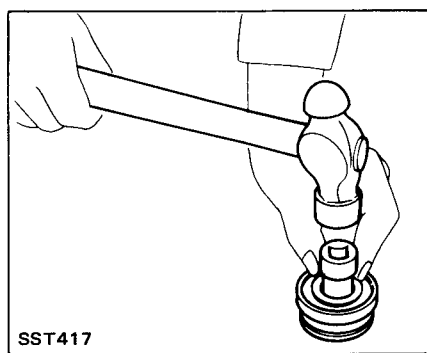

Pinion oil seal

1. Install steering gear on Tool KV48102100 in a vice.
2. Before disassembling, put matching marks on rear housing and pinion housing.

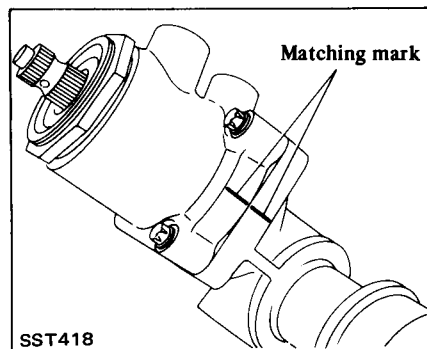

3. Remove cylinder tubes.

Refer to Cylinder Tubes for disassembly.

4. Remove retainer.

Refer to Retainer for disassembly.

5. Remove rear cover.

Refer to Stub Shaft Oil Seal for disassembly.

6. Disconnect rear housing fixing bolts using torx wrench.

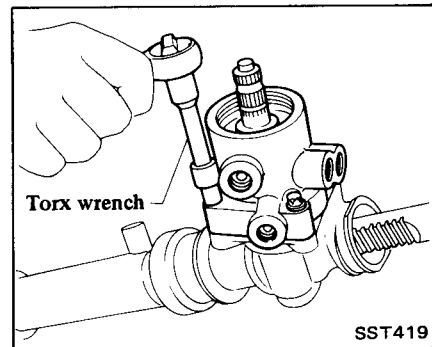

7. Remove rear housing and then remove O-ring.

Always replace O-ring when disassembled.

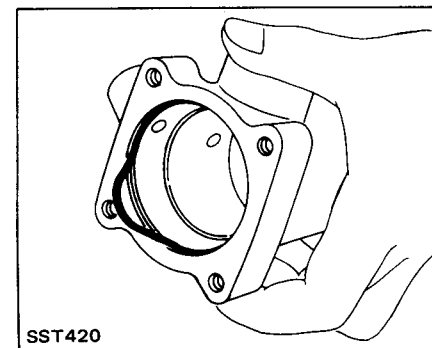

8. Remove two thrust washers and needle bearing from upper surface of pinion.

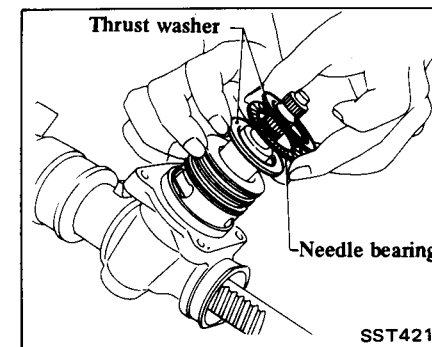

9. Remove pinion assembly and then remove thrust washers and needle bearing.

- a. Do not hammer pinion assembly nor damage its teflon seal.
- b. Do not attempt to disassemble pinion assembly.

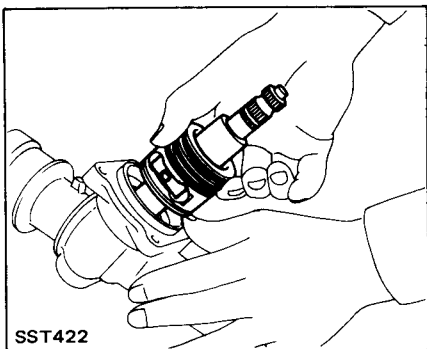

10. Remove pinion bearing and pinion oil seal using suitable tool.

Always replace oil seal when disassembled.

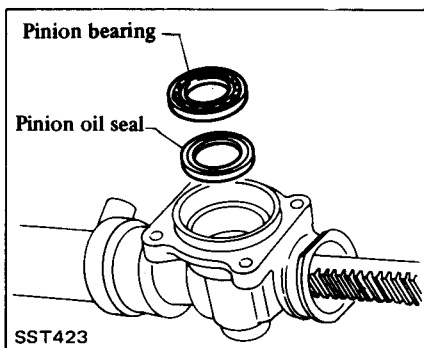

Rack bush assembly (Cylinder end housing)

1. Install steering gear on Tool KV48102100 in a vice.
2. Remove side rod and breather tube.

Refer to Side Rod and Breather Tube for disassembly.

3. Remove cylinder tubes.

Refer to Cylinder Tubes for disassembly.

4. Put matching mark.

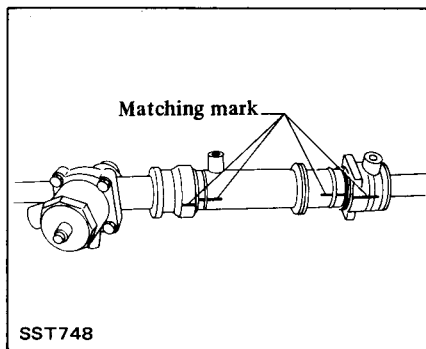

5. Remove cylinder end housing using Tool.

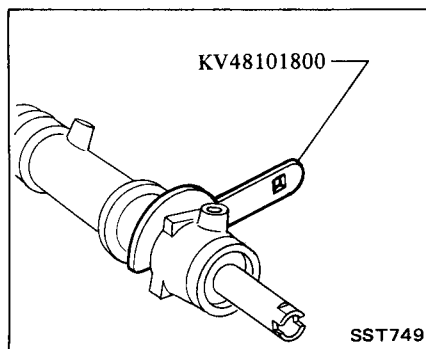

6. Disconnect cylinder lock nut using Tool and separate cylinder from pinion housing.

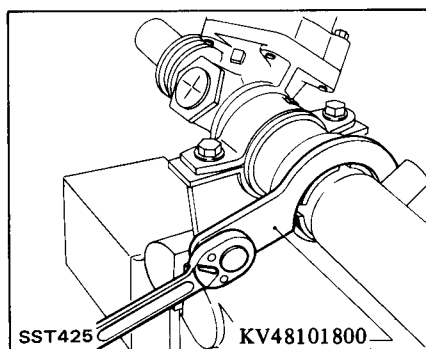

7. Remove rack bush assembly using suitable tool and discard it.

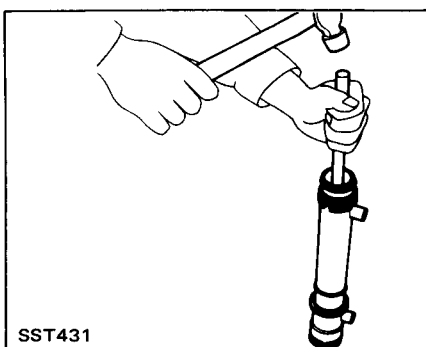

8. Remove cylinder O-rings and discard.

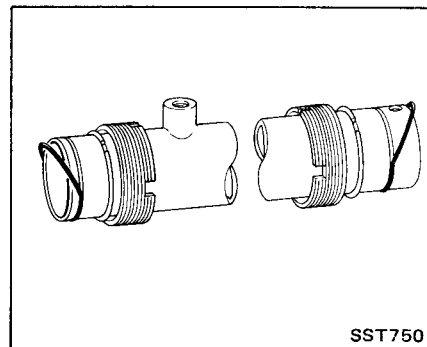

Rack packing (Inner tube)

1. Install steering gear on Tool KV48102100 in a vice.
2. Remove side rod and breather tube.

Refer to Side Rod and Breather Tube for disassembly.

3. Remove cylinder tubes.

Refer to Cylinder Tubes for disassembly.

4. Remove retainer.

Refer to Retainer for disassembly.

5. Remove cylinder end cover and cylinder assembly.

Refer to Rack Bush Assembly (Cylinder End Housing) for disassembly.

6. Remove pinion assembly.

Refer to Stub Shaft Oil Seal for disassembly.

7. Draw out rack from pinion housing.

8. Remove inner tube assembly from pinion housing.

9. Remove O-ring and inner tube collar from inner tube.

Always replace O-ring when disassembled.

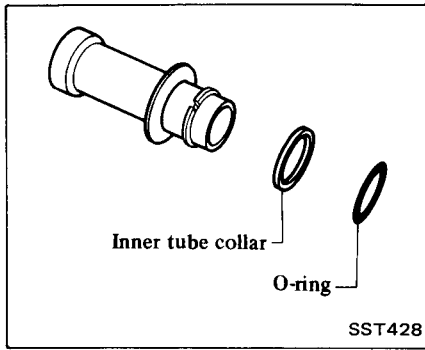

10. Remove rack packing and back-up collar using suitable tool.

Always replace rack packing when disassembled.

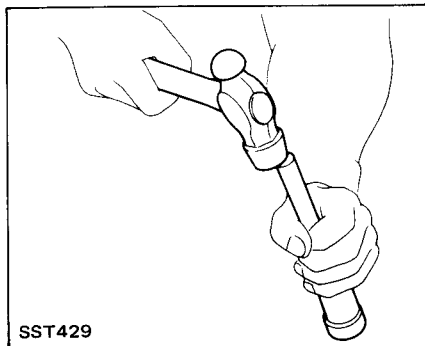

INSPECTION

Thoroughly clean all parts in cleaning solvent or automatic transmission fluid "Dexron Type", and blow dry with compressed air, if available.

Oil seals and O-rings

Always replace oil seals and O-rings when disassembled.

Snap rings

Always replace snap rings when disassembled.

Side rod outer ball joint

Ball joint is assembled at factory and cannot be disassembled.

1. Check ball joint for play. If ball stud is worn and play in axial direction is excessive or joint is hard to swing, replace as a complete unit.

Side rod outer ball joint:

Swinging torque
0.3 - 2.9 N·m
(3 - 30 kg-cm,
2.6 - 26.0 in-lb)

2. Check condition of dust cover. If it is cracked excessively, replace ball joint.

Side rod inner ball joint

Ball joint is assembled at factory and cannot be disassembled.

1. Check ball joint for play. If ball stud is worn and play in axial direction is excessive or joint is hard to swing, replace as a complete unit.

Side rod inner ball joint:

Swinging torque
0.1 - 7.8 N·m
(1 - 80 kg-cm,
0.9 - 69.4 in-lb)

Axial play
0 mm (0 in)

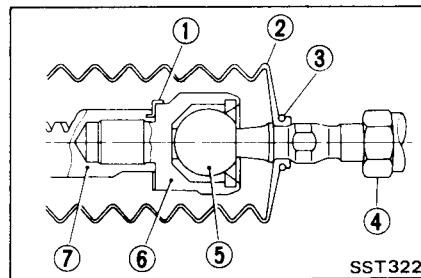

- | | |
|--------------|--------------------|
| 1 Lock plate | 5 Inner ball joint |
| 2 Boot | 6 Inner socket |
| 3 Boot clamp | 7 Rack |
| 4 Lock nut | |

2. Check condition of boot. If it is cracked excessively, replace it.

Cylinder tubes and breather tube

Check cylinder tubes and breather tube for scratches or other damage. Replace if necessary.

Steering gear component parts

Thoroughly examine those component parts. If those parts are damaged, cracked or worn, replace as steering gear assembly.

ASSEMBLY AND ADJUSTMENT

CAUTION:

- When assembling power steering gear, apply a coat of automatic transmission fluid "Dexron Type" as necessary.
- Be careful not to damage or deform O-rings and oil seals when installing them.

Assemble power steering gear and linkage in reverse order of disassembly. Observe the following instructions.

Side rod and breather tube

1. Apply locking agent to threaded portion of inner socket and fit inner socket to rack end together with new lock plate.

Be sure lock plate ratchet enters groove at end portion of rack so that rack and inner socket fit snugly.

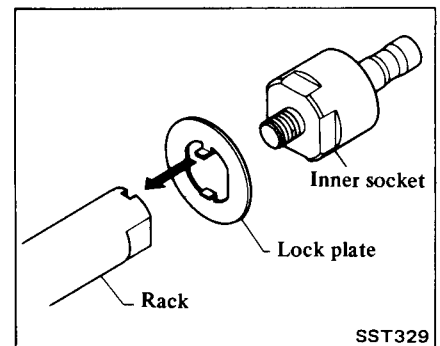

2. Tighten inner socket and securely bend lock plate at 2 cut-out portions of inner socket.

To prevent damage to boot, remove burrs after bending lock plate.

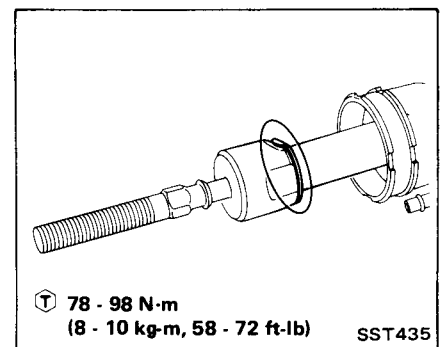

78 - 98 N·m
(8 - 10 kg-m, 58 - 72 ft-lb)

SST435

3. Screw in side rod outer socket until the distance shown in the figure below is reached. Then tighten lock nut.

⊕ : 78 - 98 N·m
(8 - 10 kg·m, 58 - 72 ft·lb)

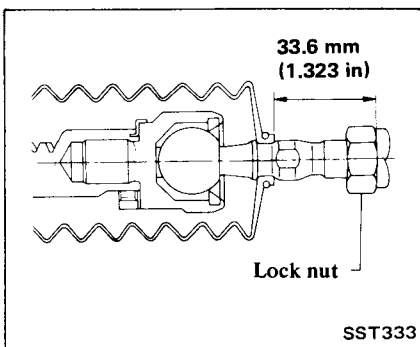

Side rod outer socket for the left side has an L-mark. (R-mark is used for the right side.)

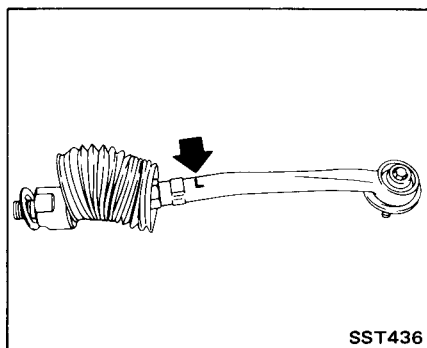

4. Measure rack stroke (both sides).

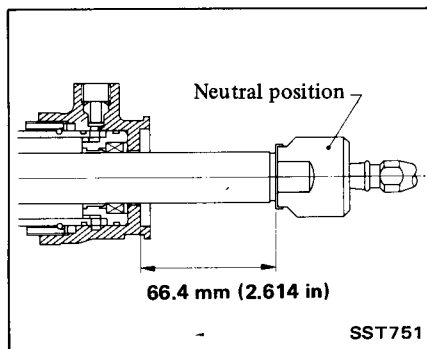

5. Apply a coat of sealant to contact surfaces between boot and cylinder and breather tube before installing boot.

Do not block through hole in breather tube with sealant.

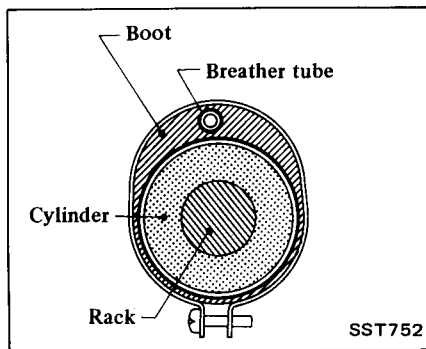

6. Set breather tube as shown below, and tighten boot clamp.

Locate clamp bolt in its place opposite to breather tube.

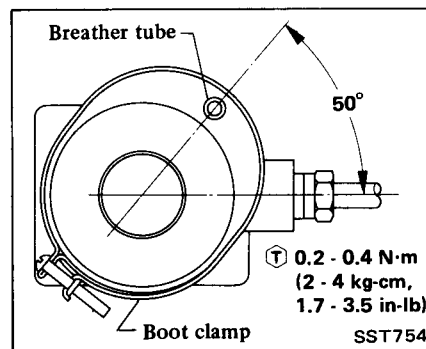
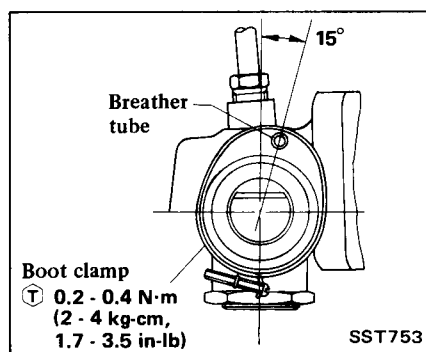

7. Upon completion of assembly, make sure that rack operates smoothly, that boot is not deformed, and that clamp is tightly in place.

Cylinder tubes

1. On cylinder tube "R", temporarily tighten flare nut at rear housing side and then the other one at cylinder side. Finally tighten these nuts to specified torque.

Be careful not to damage flare nut.

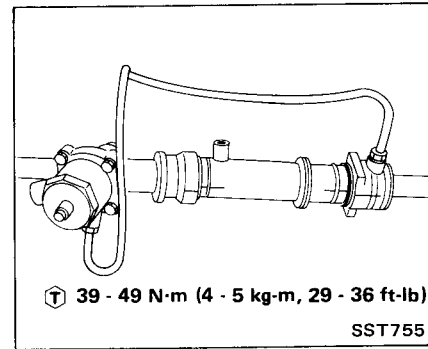

2. Install and tighten flare nuts for cylinder tube "L" in the same way.

Retainer

1. Apply a coat of grease to contact surfaces with rack, and install retainer to pinion housing.

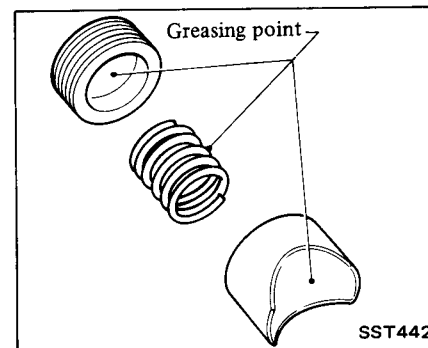

2. Install retainer spring and fully tighten adjust screw.

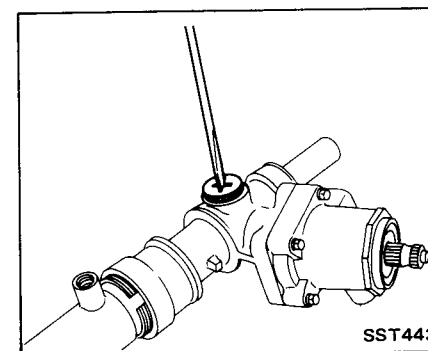

3. Turn back adjust screw 20 to 25° and tighten lock nut.

⊕ : 39 - 59 N·m
(4 - 6 kg·m,
29 - 43 ft·lb)

4. Measure pinion rotating torque and rack starting force. If they are not within specifications, readjust.

a. Pinion rotating torque

Less than 0.9 N·m (9 kg-cm, 7.8 in-lb) on average and less than 1.5 N·m (15 kg-cm, 13 in-lb) at maximum

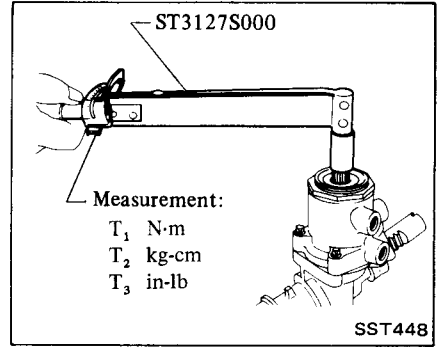
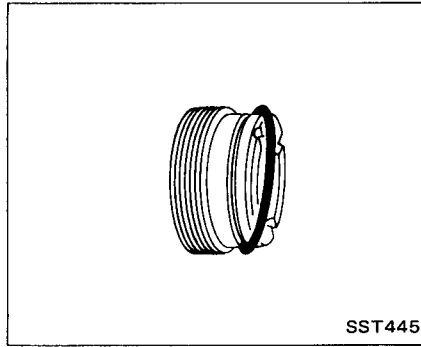
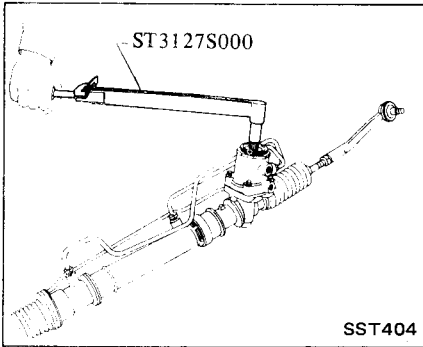

3. Fit rear housing lock nut by approximately 10 pitches on rear housing cover.

6. Tighten rear housing cover until pinion rotating torque is within specified range, using Tool.

Ⓣ : Stub shaft preload
 $T_1 + 0.15$ to 0.25 N·m
 $(T_2 + 1.5$ to 2.5 kg-cm,
 $T_3 + 1.3$ to 2.2 in-lb)

b. Rack starting force

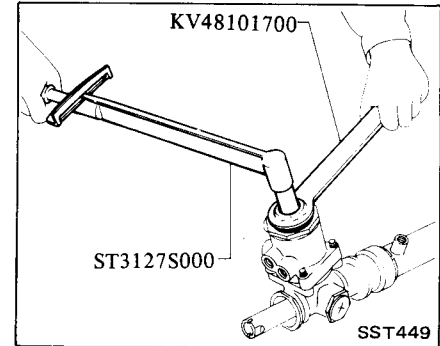
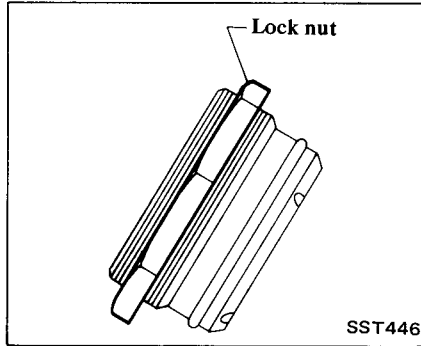
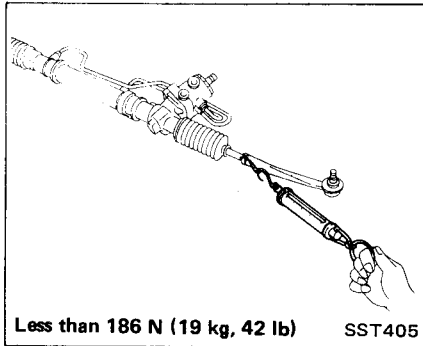

4. Completely tighten rear housing cover assembly to pinion housing and then turn back one pitch from that position.

7. Tighten rear cover lock nut using Tool.

Stub shaft oil seal

1. Apply a coat of automatic transmission fluid to new stub shaft oil seal and press it into rear housing cover using a suitable tool.

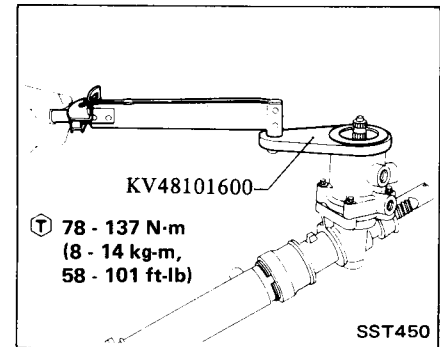
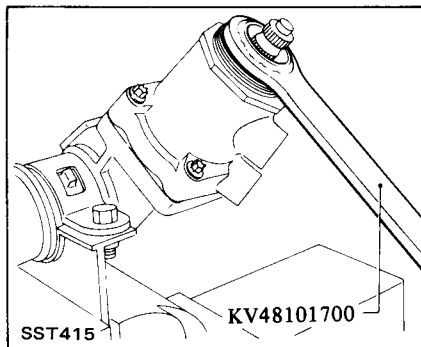
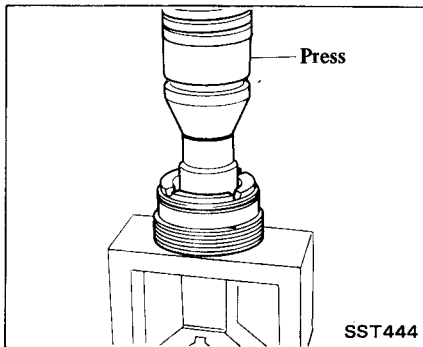

2. Apply a coat of automatic transmission fluid to new O-ring before installing it.

5. Turn stub shaft all the way to right and left several times. Measure pinion rotating torque (pinion bearing friction).

8. Remeasure pinion rotating torque. If it is not within specifications, re-adjust.

Ⓣ : Less than 0.9 N·m (9 kg-cm, 7.8 in-lb)

9. Install retainer and adjust pinion rotating torque.

Refer to Retainer for assembly.

Pinion oil seal

1. Press new pinion oil seal into pinion housing, using a suitable tool.

Be sure to apply a coat of automatic transmission fluid to oil seal before installing it.

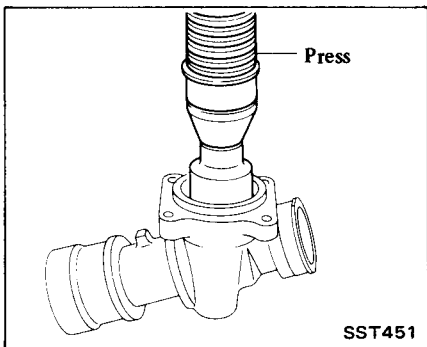

Apply a coat of bearing grease to oil seal lip.

2. Attach two thrust washers and thrust bearing and install pinion bearing.

Apply grease to bearing.

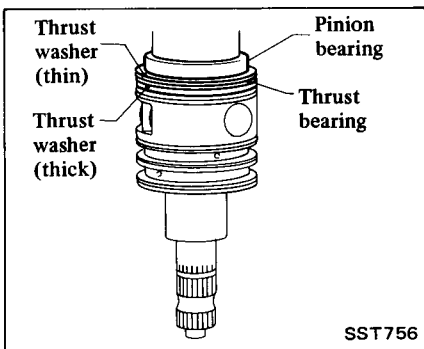

3. Situate rack as shown in figure below.

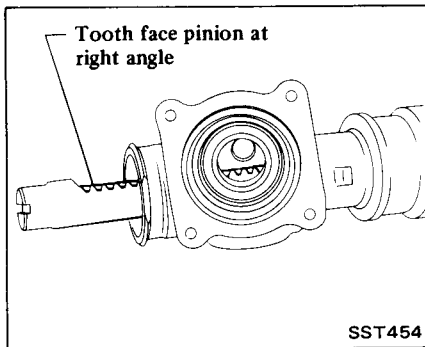
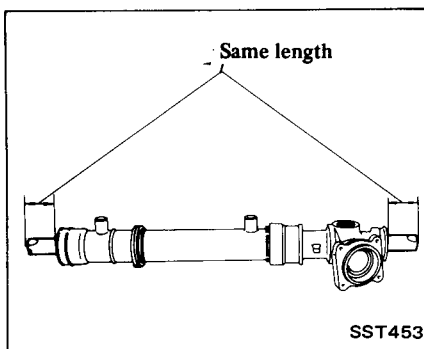

4. Install pinion assembly so that punch mark on pinion stub shaft is located exactly on rear side as it is mounted in car.

- a. Be careful not to damage pinion oil seal.
- b. Do not apply any undue pressure to pinion stub shaft.
- c. Apply a coat of grease to rack and pinion gear.

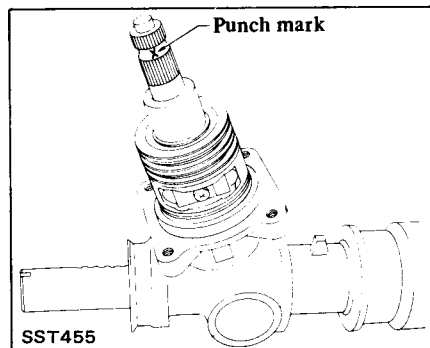

5. Apply a coat of automatic transmission fluid to new O-ring before installing it.

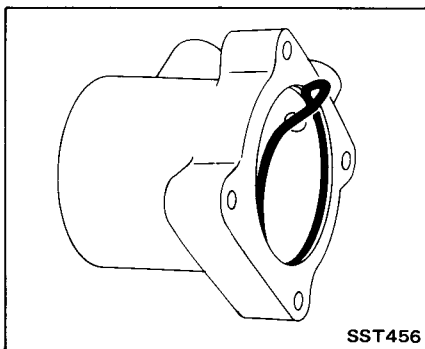

6. Install rear housing by aligning matching marks.

Be careful not to damage pinion teflon ring.

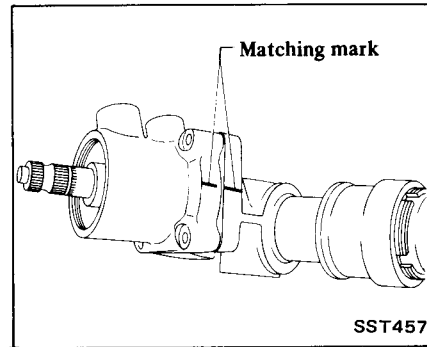

If a matching mark is not present, position cylinder as follows:

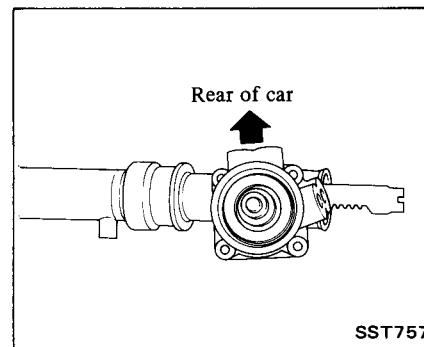

7. Tighten rear housing fixing bolts using torx wrench.

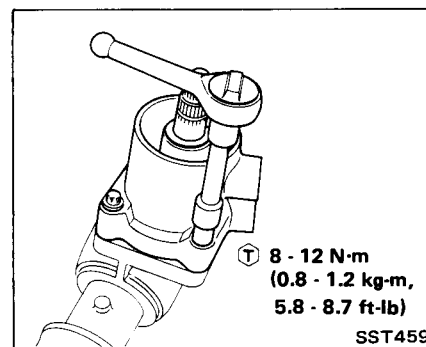

8. Properly position thrust washer and needle bearing on pinion's upper surface.

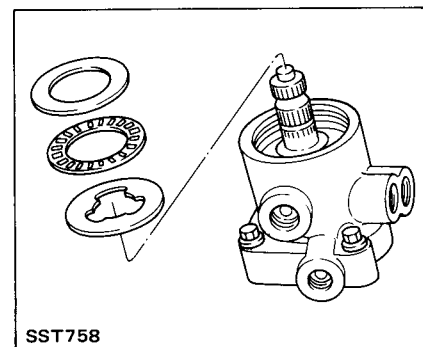

9. Install rear cover.

Refer to **Stub Shaft Oil Seal for assembly.**

10. Install retainer and adjust pinion rotating torque.

Refer to **Retainer for assembly.**

11. Install cylinder tubes.

Refer to **Cylinder Tubes for assembly.**

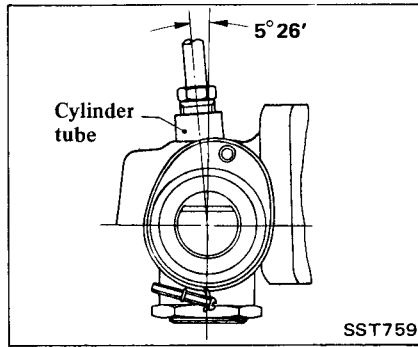

If a matching mark is not present, position cylinder end housing as follows:

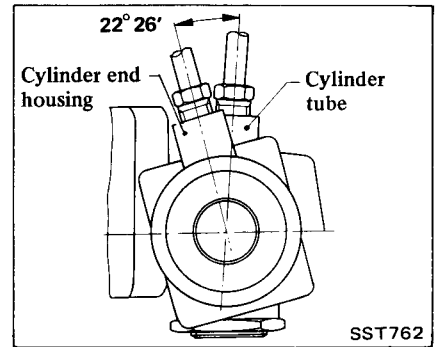

Rack bush assembly (Cylinder and housing)

1. Apply a coat of automatic transmission fluid to new O-ring before installing it on cylinder.

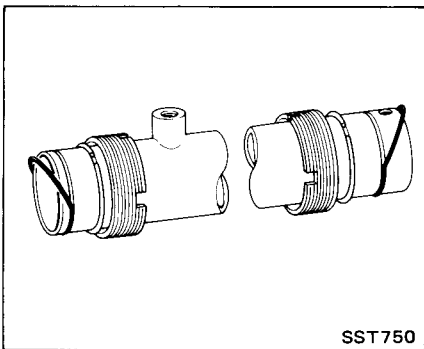

3. Tighten cylinder lock nut using Tool.

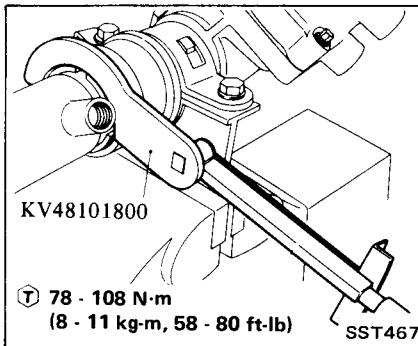

5. Tighten cylinder end housing using Tool.

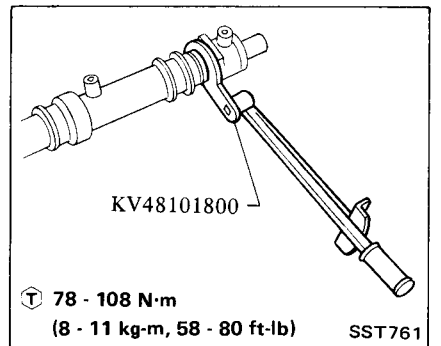

2. Position cylinder on pinion housing by aligning matching marks.

Be careful not to damage piston teflon ring.

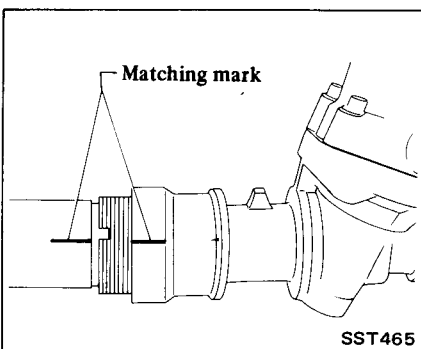

4. Wrap cellophane tape around rack end. Then place a new rack bush assembly and back-up washer onto rack end. Next align cylinder end housing at matching marks.

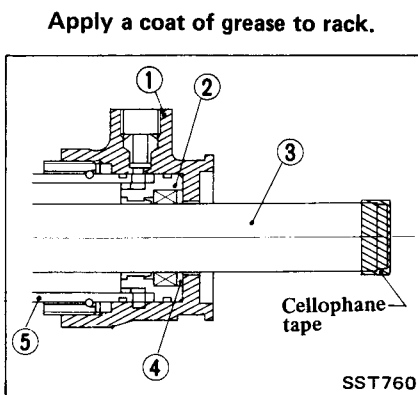

6. Install cylinder tubes.

Refer to **Cylinder Tubes for assembly.**

7. Install side rod and breather tube.

Refer to **Side Rod and Breather Tube for assembly.**

Rack packing (Inner tube)

1. Apply a coat of automatic transmission fluid to new O-ring when installing it to inner tube.

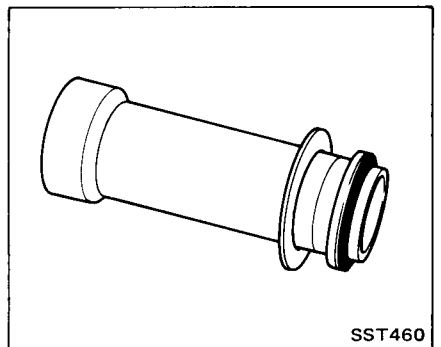

If a matching mark is not present, position cylinder as follows:

- 1 Cylinder end housing
- 2 Rack bush assembly
- 3 Rack
- 4 Back-up washer
- 5 Cylinder assembly

2. Attach back-up collar to inner tube and press new rack packing into place, using a suitable tool.

Pressing force:
Less than 5,884 N
(600 kg, 1,323 lb)

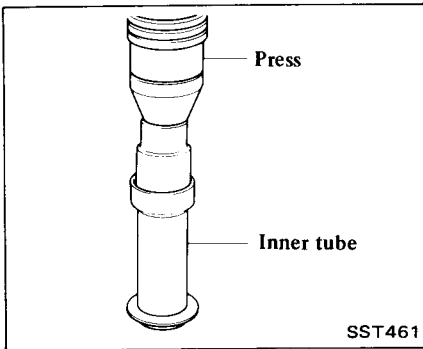

3. Insert inner tube assembly.

- Place plastic film on inner side of rack packing to prevent damage by rack teeth.
- Always remove plastic film after rack packing is positioned properly.

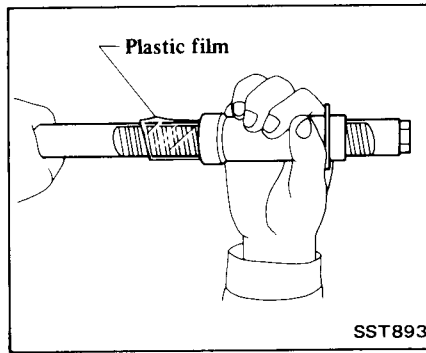

4. Insert rack assembly, and then set inner tube assembly to pinion housing.

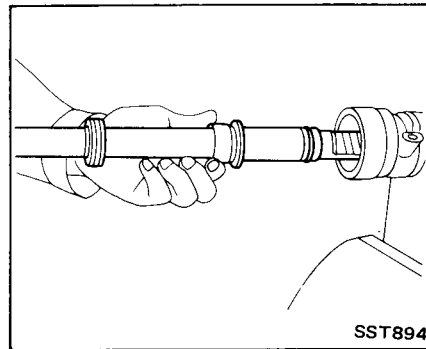

5. Install cylinder and rack bush assembly.

Refer to Rack Bush Assembly (Cylinder end housing) for assembly.

6. Install pinion assembly.

Refer to Stub Shaft Oil Seal for assembly.

7. Install cylinder tubes.

Refer to cylinder Tubes for assembly.

8. Install side rod and breather tube.

Refer to Side Rod and Breather Tube for assembly.

POWER STEERING OIL PUMP

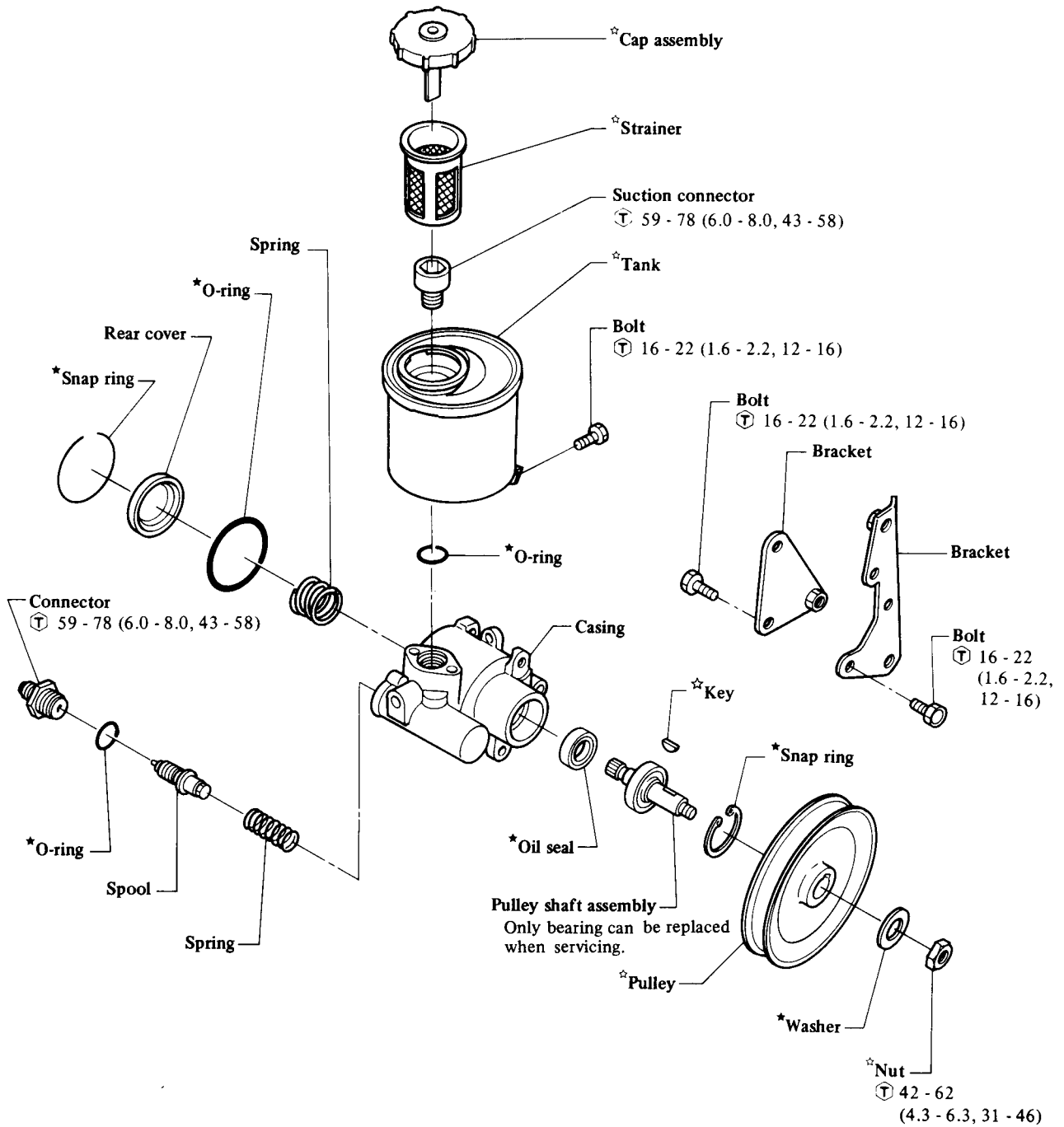

Ⓜ: N·m (kg·m, ft·lb)
 * or ☆: are available for service replacement.
 ☆: always replace when disassembled.

SST720

The power steering oil pump should be disassembled only if any of the following phenomena is noted.

- Oil leak at the following points

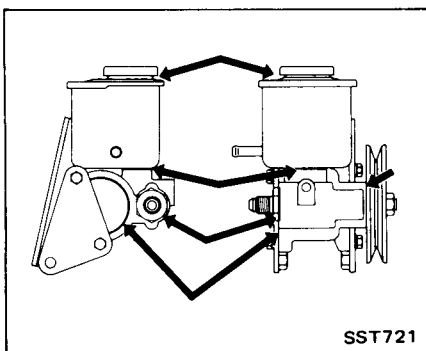

- Deformed or damaged pulley
- Deformed or damaged cap assembly or strainer

CAUTION:

This power steering oil pump is a precision hydraulic unit. Extreme care should be taken to prevent entry of dust, dirt, metal chips, etc. into oil pump during disassembly.

DISASSEMBLY

Pulley

Remove pulley.

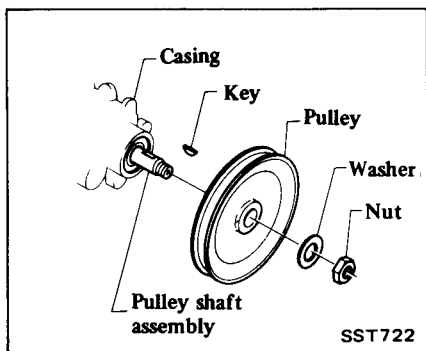

Do not reuse washer once it has been removed.

Cap assembly and strainer

Remove cap assembly.

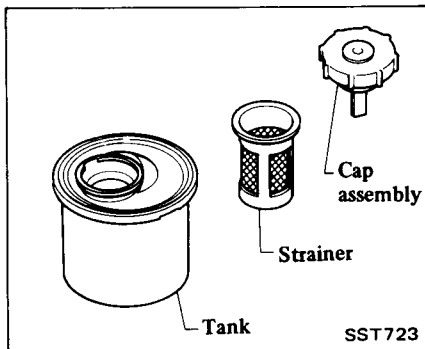

Tank O-ring

1. Remove tank.

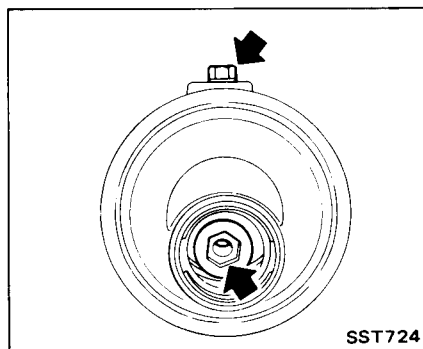

2. Remove O-ring.

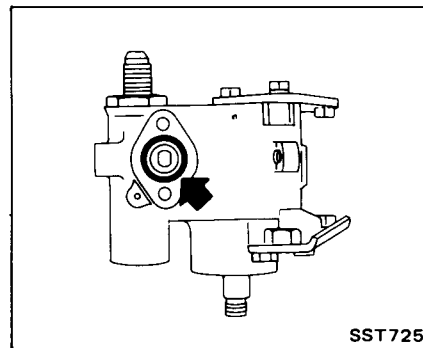

Do not reuse O-ring once it has been removed.

Connector

Remove connector, then remove O-ring.

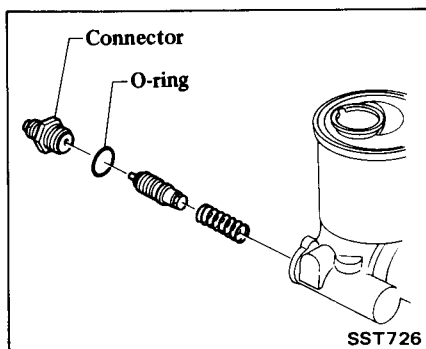

Do not reuse O-ring once it has been removed.

Rear cover O-ring

1. Remove tank.

Refer to "Tank O-ring" for disassembly.

2. Remove bracket.

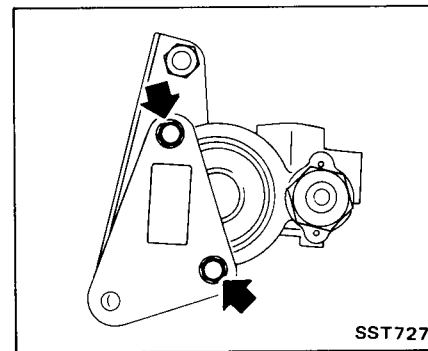

3. Remove snap ring.

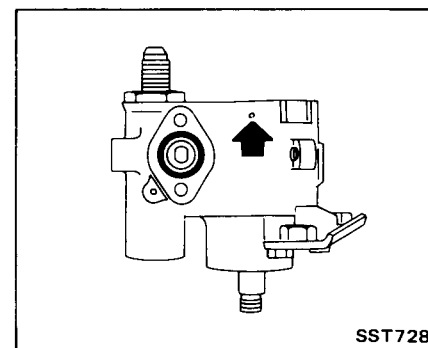

Do not reuse snap ring once it has been removed.

4. Remove rear cover and spring.
5. Remove O-ring.

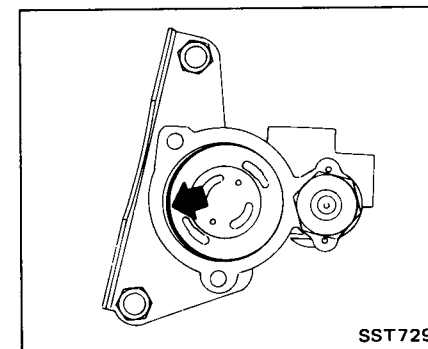

Do not reuse O-ring once it has been removed.

CAUTION:

Do not face rear cover side of housing downwards, nor jar the housing; otherwise, the side plate, etc. may fall. If dropped, do not attempt to reassemble them; rather replace oil pump assembly.

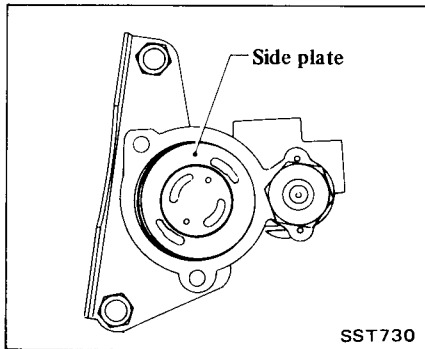

Pulley shaft oil seal

1. Remove pulley.

Refer to "Pulley" for disassembly.

2. Remove snap ring, then remove pulley shaft assembly.

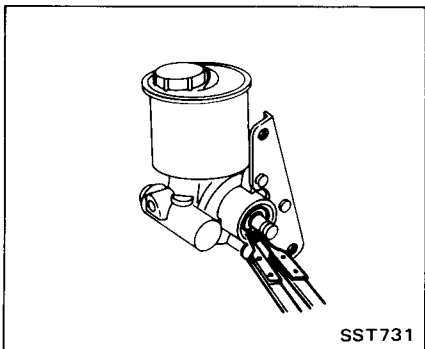

Do not reuse snap ring once it has been removed.

3. Remove oil seal.

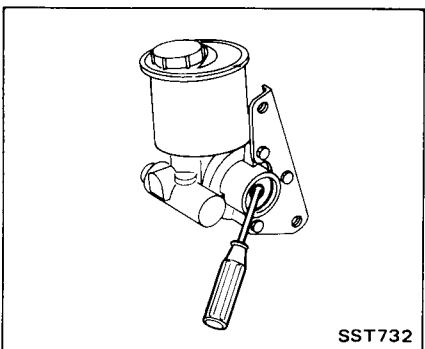

Do not reuse oil seal once it has been removed.

INSPECTION

Wash clean all disassembled parts in suitable cleaning solvent.

Discard any oil seals and O-rings which have once been removed.

Replace oil seal and O-ring if sealing surface is deformed or cracked.

Pulley and pulley shaft

- a. If pulley is cracked or deformed, replace it.
- b. If an oil leak is noticed around pulley shaft oil seal, replace it.
- c. If key or pulley's key groove is deformed or worn, replace oil pump assembly.

Cap assembly and strainer

- a. If cap assembly is deformed, damaged, or cracked, replace it.
- b. If an oil leak is noticed, replace cap assembly. If cap contacting portion of tank is damaged or deformed, replace tank.

Tank

- a. If tank is deformed or cracked, replace it.
- b. If an oil leak is noticed, replace O-ring.

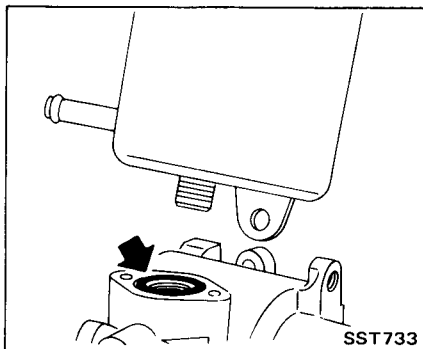

Connector

- a. If connector is deformed or cracked, replace oil pump assembly.
- b. If an oil leak is noticed, replace O-ring.

Rear cover

If an oil leak is noticed, replace O-ring.

CAUTION:

- a. When disassembling, reassembling or inspecting, use utmost care not to damage housing and rear cover contacting portion. If damaged accidentally, do not attempt to reassemble them; rather replace oil pump assembly.
- b. When rear cover is removed, do not face housing downwards; or the side plate, etc. may fall. If dropped, do not attempt to reassemble them; rather replace oil pump assembly.

ASSEMBLY

Pulley

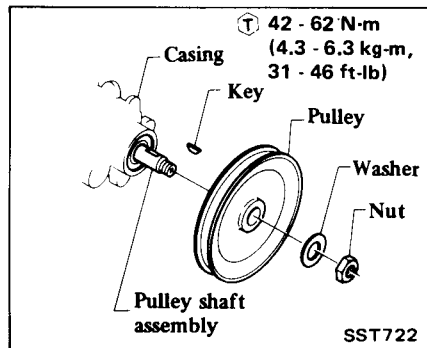

- a. Always use new washer.
- b. After tightening nuts securely, be sure to bend washer.

Cap assembly and strainer

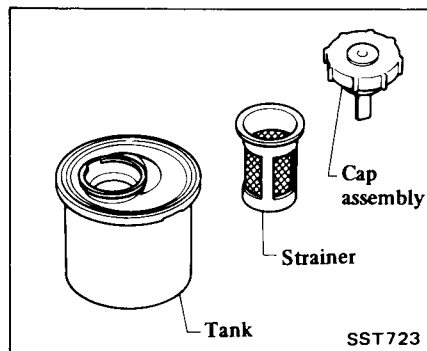

Tank O-ring

1. Install new O-ring.
 - a. Before installing, apply a thin coat of vaseline to O-ring.
 - b. Make certain that O-ring is installed properly.
2. Install tank.

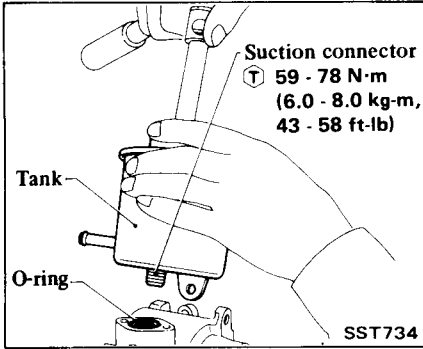

Use utmost care not to damage O-ring when installing suction connector.

3. Install bolt.

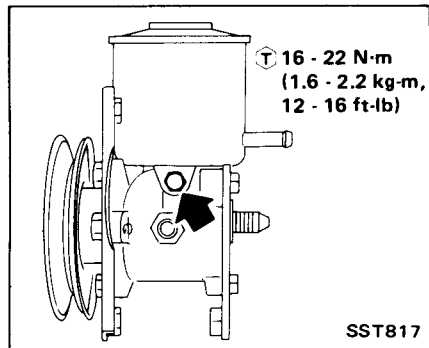

4. Install cap assembly.

Refer to "Cap assembly and strainer" for assembly.

Rear cover O-ring

1. Install new O-ring.

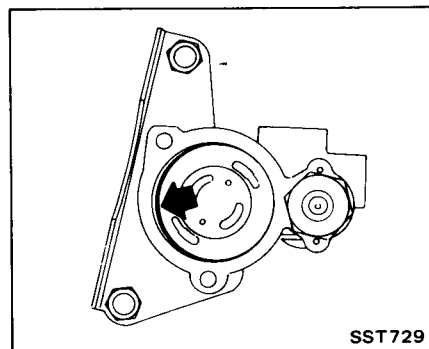

- a. Before installing, apply a thin coat of vaseline to O-ring.
 - b. Make certain that O-ring is installed properly.
2. Install spring, and press rear cover with a hydraulic press so that snap ring can be installed.

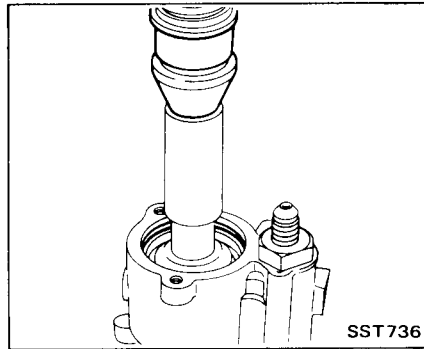

3. Install new snap ring.
4. Install bracket.

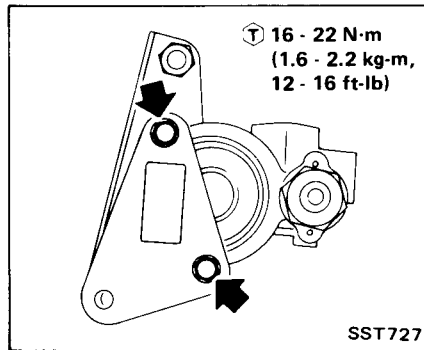

5. Assemble by referring to "Assembly of Tank O-ring".

Pulley shaft oil seal

1. Using a suitable tool, install new oil seal.

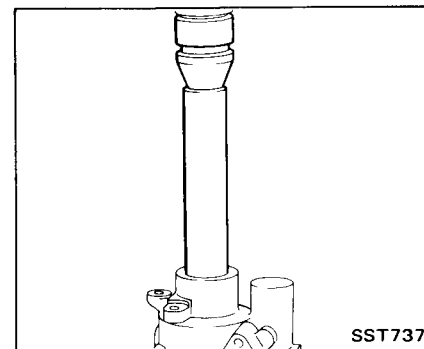

Before installing, apply a thin coat of vaseline to oil seal.

2. Securely install pulley shaft assembly by adjusting with screwdriver until rotor comes to the center position.

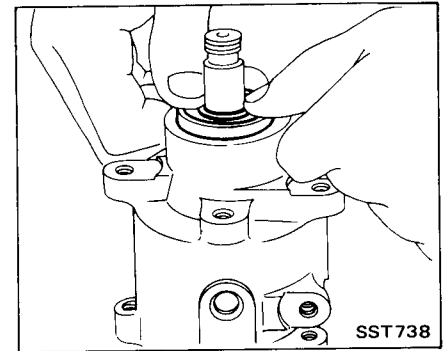

3. Install new snap ring.

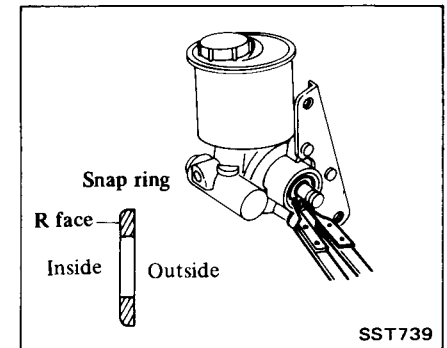

4. Install pulley.

Refer to "Pulley" for assembly.

Connector

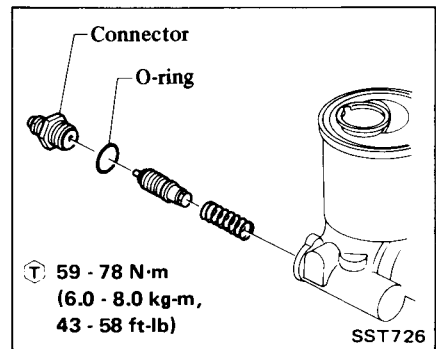

- a. Before installing, apply a thin coat of vaseline to O-ring.
- b. Make certain that O-ring is installed properly.

SERVICE DATA AND SPECIFICATIONS (S.D.S.)

GENERAL SPECIFICATIONS

Steering column	Collapsible column
Steering gear type	
Manual steering gear	RP15L (Rack-and-pinion)
Power steering gear	IPRP15L
Turns of steering wheel (Lock to Lock)	
RP15L	3.5
IPRP15L	3.2
Steering gear ratio (Overall ratio)	
RP15L	19.6 : 1
IPRP15L	17.8 : 1
Standard clearance between upper jacket head and lower jacket mm (in)	399.5 - 400.5 (15.73 - 15.77)

INSPECTION AND ADJUSTMENT

	RP15L, IPRP15L
Front wheel turning angle degree	
Inside	33-1/2° - 37-1/2°
Outside	29° - 33°
Steering wheel axial play mm (in)	
Equipped with RP15L	0 (0)
Equipped with IPRP15L	0 (0)
Steering wheel play mm (in)	
Equipped with RP15L	20 - 30 (0.79 - 1.18)
Equipped with IPRP15L	Less than 35 (1.38)

MODEL : RP15L

Side rod outer ball joint Swinging torque N·m (kg-cm, in-lb)	0.3 - 4.9 (3 - 50, 2.6 - 43.4)
Side rod inner ball joint Swinging torque N·m (kg-cm, in-lb)	0 - 4.9 (0 - 50, 0 - 43)
Pinion gear turning torque (Pinion gear and rack gear assembly) N·m (kg-cm, in-lb)	Less than 2.0 (20, 17)
Rack force to pull N (kg, lb)	Less than 98 (10, 22)
Side rod length mm (in)	29.5 (1.161)
Pinion bearing inner snap ring thickness mm (in)	1.04 - 1.09 (0.0409 - 0.0429) 1.09 - 1.14 (0.0429 - 0.0449) 1.14 - 1.19 (0.0449 - 0.0469) 1.19 - 1.24 (0.0469 - 0.0488) 1.24 - 1.29 (0.0488 - 0.0508)
Pinion bearing outer snap ring thickness mm (in)	1.55 - 1.60 (0.0610 - 0.0630) 1.60 - 1.65 (0.0630 - 0.0650) 1.65 - 1.70 (0.0650 - 0.0669) 1.70 - 1.75 (0.0669 - 0.0689)

MODEL: IPRP15L

Side rod outer ball joint Axial play mm (in)	0.1 - 0.8 (0.004 - 0.031)
Swinging torque N·m (kg-cm, in-lb)	0.3 - 2.9 (3 - 30, 2.6 - 26.0)
Side rod inner ball joint Axial play mm (in)	0 (0)
Swinging torque N·m (kg-cm, in-lb)	0.1 - 7.8 (1 - 80, 0.9 - 69.4)
Pinion rotating torque (Gear assembly) N·m (kg-cm, in-lb)	Less than 1.5 (15, 13)
Rack starting force (Gear assembly) N (kg, lb)	Less than 186 (19, 42)
Side rod length mm (in)	33.6 (1.323)
Oil pump belt deflection mm (in)	8 - 12 (0.31 - 0.47) at 98 N (10 kg, 22 lb)
Steering wheel turning force N (kg, lb)	24.5 - 29.4 (2.5 - 3.0, 5.5 - 6.6)
Normal operating temperature at fluid °C (°F)	60 - 80 (140 - 176)
Oil pump maximum pressure kPa (kg/cm ² , psi)	6,571 - 7,748 (67 - 79, 953 - 1,123)
Fluid capacity ℓ (US qt, Imp qt)	1.1 (1-1/8, 1)

TIGHTENING TORQUE

STEERING COLUMN

Unit	N·m	kg·m	ft·lb
Steering wheel nut	39 - 49	4.0 - 5.0	29 - 36
Jacket tube bracket and cover to dash panel	3.4 - 4.4	0.35 - 0.45	2.5 - 3.3
Steering column mounting bracket	13 - 18	1.3 - 1.8	9 - 13
Coupling to column shaft	16 - 22	1.6 - 2.2	12 - 16
Lower joint to rubber coupling	23 - 26	2.3 - 2.7	17 - 20
Lower joint to pinion gear (RP15L)	39 - 49	4.0 - 5.0	29 - 36
Lower joint to pinion gear (IPRP15L)	32 - 38	3.3 - 3.9	24 - 28

STEERING GEAR AND LINKAGE

Model : RP15L

Unit	N·m	kg·m	ft·lb
Side rod to knuckle arm	54 - 98	5.5 - 10.0	40 - 72
Side rod lock nut	78 - 98	8.0 - 10.0	58 - 72
Gear housing clamp	45 - 60	4.6 - 6.1	33 - 44
Retainer lock nut	39 - 59	4.0 - 6.0	29 - 43
Side rod inner socket lock nut	78 - 98	8.0 - 10.0	58 - 72

Model: IPRP15L

Unit	N·m	kg·m	ft·lb
Side rod to knuckle arm	54 - 98	5.5 - 10.0	40 - 72
Side rod lock nut	78 - 98	8.0 - 10.0	58 - 72
Gear housing clamp	45 - 60	4.6 - 6.1	33 - 44
Oil pump to bracket	26 - 36	2.7 - 3.7	20 - 27
Hose to oil pump	29 - 49	3.0 - 5.0	22 - 36
Hose to gear housing	39 - 49	4.0 - 5.0	29 - 36
Side rod inner socket lock nut	78 - 98	8.0 - 10.0	58 - 72
Boots clamp securing bolt	0.2 - 0.4	0.02 - 0.04	0.1 - 0.3
Retainer lock nut	39 - 59	4.0 - 6.0	29 - 43
Rear cover lock nut	78 - 137	8.0 - 14.0	58 - 101
Cylinder lock nut	78 - 108	8.0 - 11.0	58 - 80
Rear housing fixing bolt	8 - 12	0.8 - 1.2	5.8 - 8.7
Cylinder tube flare nut	39 - 49	4.0 - 5.0	29 - 36
Pulley nut	42 - 62	4.3 - 6.3	31 - 46
Oil pump bracket	16 - 22	1.6 - 2.2	12 - 16
Oil pump to tank	16 - 22	1.6 - 2.2	12 - 16
Connector	59 - 78	6.0 - 8.0	43 - 58
Suction connector	59 - 78	6.0 - 8.0	43 - 58

TROUBLE DIAGNOSES AND CORRECTIONS





MANUAL STEERING

Refer to TROUBLE DIAGNOSES AND CORRECTIONS in “Front Axle & Front Suspension” Section.

POWER STEERING

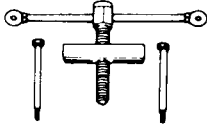
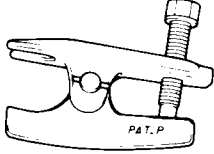
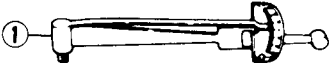
Condition	Probable cause	Corrective action
Oil pressure does not build up.	Pump drive belt slipping on pulley. Pump malfunctioning. Oil leaking through hose joints. Oil leaking through power steering.	Readjust belt tension. Replace. Replace or retighten copper washer. Replace sealing parts at steering system.
Steering wheel moves heavily.	Lack of oil in oil pump.* Air present in oil. Oil pressure too low. Wheel alignment out of specifications or air pressure in tires too low.* Steering gears improperly engaged.* Steering column out of alignment.* Worn or damaged ball joint at suspension and steering linkage.*	Refill. Bleed air. See “Hydraulic system check”. Re-align or inflate tires to correct pressure. Replace gear assembly. Repair or replace. Replace.
Steering wheel fails to return.	Refer to items marked “*” above. Front wheel caster improperly adjusted. Internal gears dragged or gouged.	Readjust. Replace gear assembly.
Steering effort is not the same in both directions.	Oil leakage in steering gear. Stuffy oil passage in steering gear.	Replace sealing parts. Replace gear assembly.
Unstable running.	Wheel bearing not properly adjusted. Stuck or damaged control valve in steering gear. Front wheel alignment not properly. Excessive steering gear play. Play at suspension and linkage ball joint.	Readjust. Replace gear assembly. Readjust. Readjust backlash or replace gear assembly. Replace.
Noisy pump.	Lack of oil in oil pump. Hoses or oil filter clogged. Loose pulley. Belt noisy or slapping. Broken pump part.	Refill. Clean or, if necessary, replace. Repair. Readjust tension. Replace.

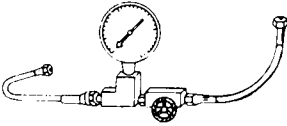
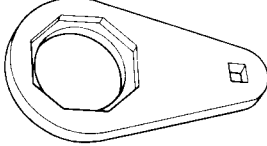
SPECIAL SERVICE TOOLS

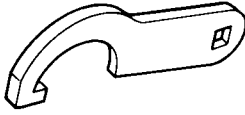
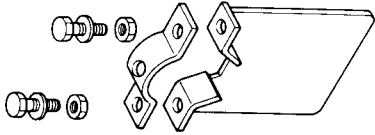
Tool number (Kent-Moore No.)	Tool name	Unit application	
		RP15L	IPRP15L
ST27180001 (J25726)	Steering wheel puller 	X	X
HT72520000 (J25730-A)	Ball joint remover 	X	X
ST3127S000 (See J25765)	Preload gauge		
① GG91030000 (J25765)	Torque wrench 		
② HT62900000 (-)	Socket adapter (Useless) 	-	X
③ HT62940000 (-)	Socket adapter (Useless) 		
ST27091000 (J26357)	Pressure gauge 	-	X
KV48101600 (J28818)	Rear housing lock nut wrench 	-	X
KV48101700 (J28819)	Rear cover wrench 	-	X
KV48101800 (J28820)	Cylinder lock nut wrench 	-	X
KV48102100 (J28817)	Power steering stand 	-	X