

REAR AXLE & REAR SUSPENSION

SECTION RA

CONTENTS

REAR SUSPENSION	RA- 2	DRIVE SHAFT (Cardan universal joint type) . . .	RA- 9
REAR AXLE AND SUSPENSION		DRIVE SHAFT (Tripod universal joint type) . . .	RA-11
ASSEMBLY	RA- 3	SERVICE DATA AND	
SUSPENSION MEMBER AND		SPECIFICATIONS (S.D.S.)	RA-15
STABILIZER	RA- 5	GENERAL SPECIFICATIONS	RA-15
COIL SPRING AND SHOCK ABSORBER		INSPECTION AND ADJUSTMENT	RA-16
ASSEMBLY	RA- 6	TIGHTENING TORQUE	RA-16
REAR AXLE	RA- 7	TROUBLE DIAGNOSES AND	
REAR AXLE SHAFT, WHEEL BEARINGS		CORRECTIONS	RA-17
AND SEALS	RA- 7	SPECIAL SERVICE TOOLS	RA-18
SUSPENSION ARM	RA- 8		

REAR SUSPENSION

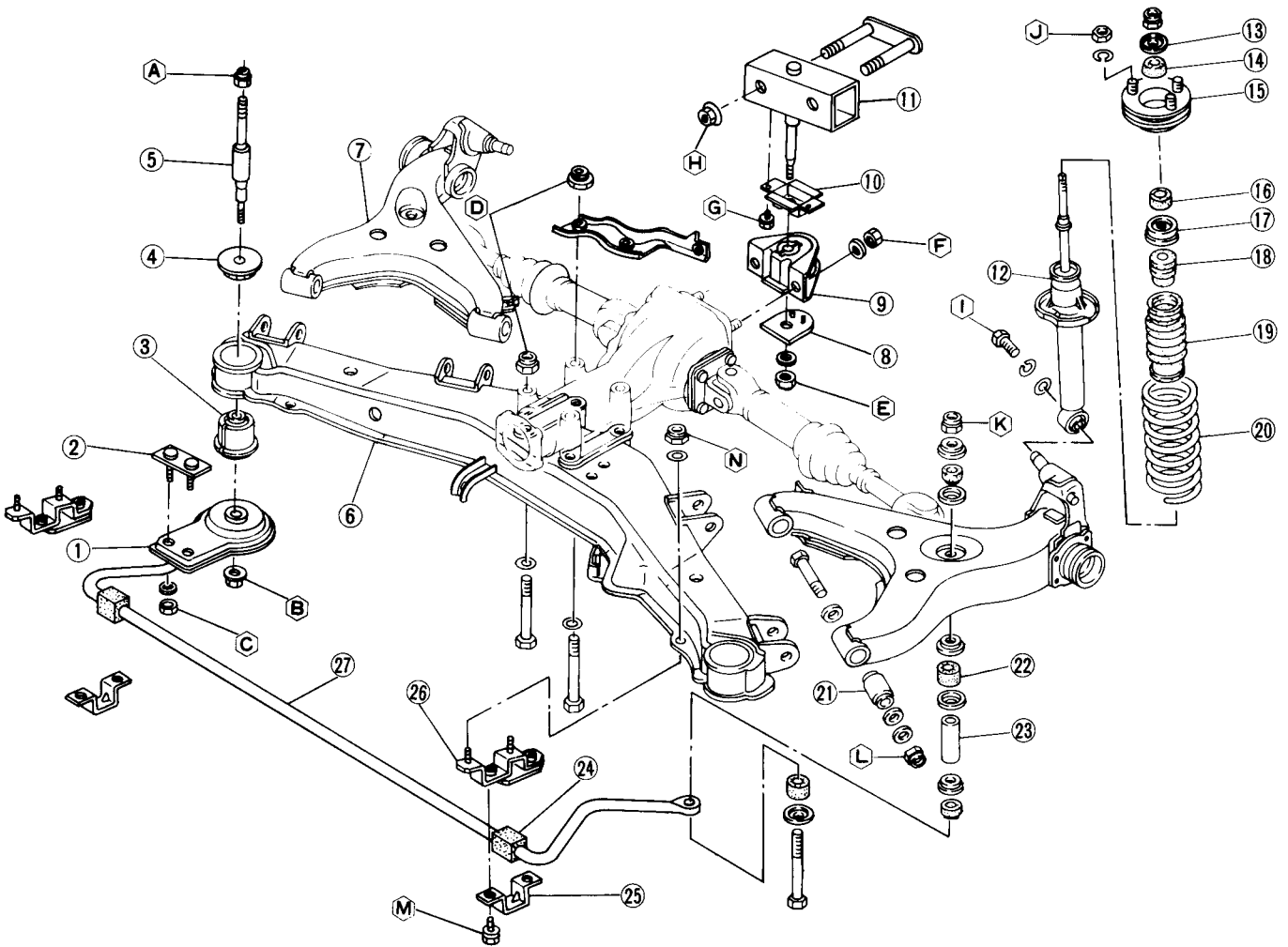

- 1 Suspension member mounting stay
- 2 Suspension member mounting bolt
- 3 Member mounting insulator
- 4 Member mounting upper stopper
- 5 Suspension mounting bolt
- 6 Suspension member assembly
- 7 Suspension arm assembly
- 8 Differential mounting plate
- 9 Differential mounting insulator
- 10 Differential mounting adapter plate
- 11 Differential mounting bracket
- 12 Shock absorber assembly
- 13 Special washer
- 14 Shock absorber mounting bushing A

- 15 Shock absorber mounting insulator
- 16 Shock absorber mounting bushing B
- 17 Bound bumper cover
- 18 Bound bumper
- 19 Dust cover
- 20 Coil spring
- 21 Suspension arm bushing
- 22 Stabilizer bushing
- 23 Stabilizer collar
- 24 Stabilizer mounting bushing
- 25 Stabilizer mounting clip
- 26 Stabilizer mounting bracket
- 27 Rear stabilizer

Tightening torque N-m (kg-m, ft-lb)

- A** : 118 - 157 (12 - 16, 87 - 116)
- B** : 78 - 98 (8 - 10, 58 - 72)
- C** : 20 - 25 (2.0 - 2.6, 14 - 19)
- D** : 59 - 78 (6 - 8, 43 - 58)
- E** : 118 - 147 (12 - 15, 87 - 108)
- F** : R200 Diff.:
88 - 118 (9 - 12, 65 - 87)
R180 Diff.:
59 - 78 (6 - 8, 43 - 58)
- G** : 31 - 42 (3.2 - 4.3, 23 - 31)
- H** : 59 - 78 (6 - 8, 43 - 58)
- I** : 59 - 78 (6 - 8, 43 - 58)
- J** : 29 - 39 (3 - 4, 2℄ - 29)
- K** : 16 - 21 (1.6 - 2.1, 12 - 15)
- L** : 78 - 98 (8 - 10, 58 - 72)
- M** : 16 - 21 (1.6 - 2.1, 12 - 15)
- N** : 16 - 21 (1.6 - 2.1, 12 - 15)

REAR AXLE AND SUSPENSION ASSEMBLY

REMOVAL

It is not necessary to remove rear axle and suspension assembly for any normal repairs. However, if the rear suspension member is damaged, the rear axle and the suspension member assembly may be removed and installed using the following procedure.

1. Block front wheels with chocks.
2. Raise the rear of car high enough to permit working underneath, and support it on safety stands. Place stands solidly under body member on both sides.

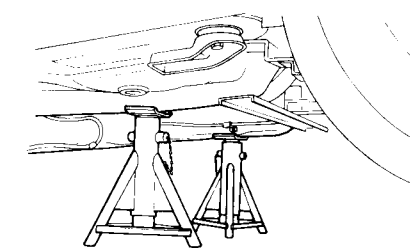

G1414

3. Remove rear wheels.
4. Remove heat shield plate located in front of fuel tank.
5. Disconnect hand brake cable by removing lock nut at adjuster and clevis pin ①.

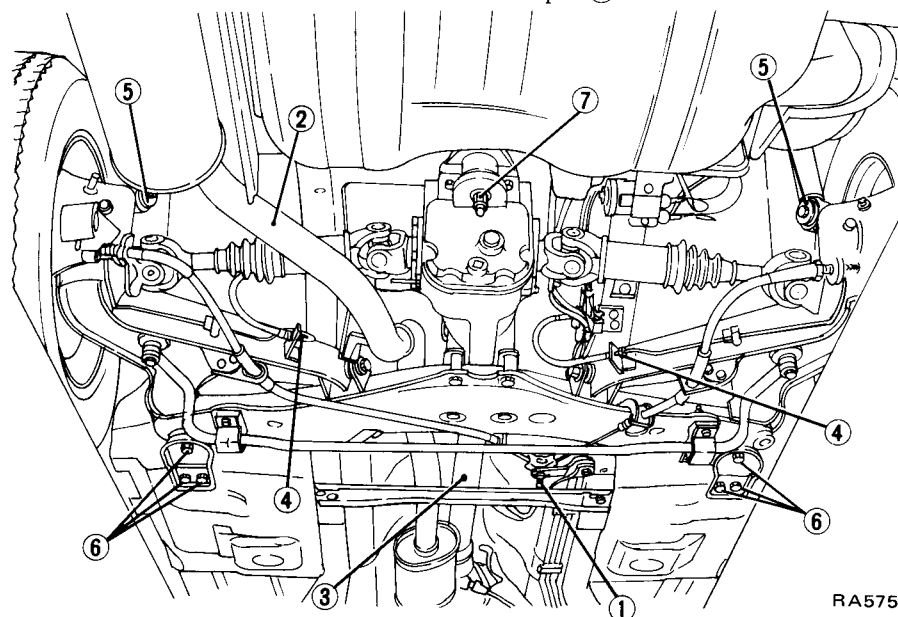

RA575

6. Remove rear exhaust tube and muffler ②. Refer to Exhaust System (Section FE).
7. Mark flange yoke of propeller shaft and companion flange of differential gear carrier for proper reassembly, then remove propeller shaft ③.
8. Disconnect rear brake hoses ④.

9. Support under center of suspension member and differential carrier with a transmission jack.
10. Disconnect shock absorbers at lower end ⑤.
11. Disconnect suspension member from body by removing nuts ⑥ at both ends of member.
12. Disconnect differential carrier mounting lock nut ⑦.
13. Carefully lower jack with suspension assembly, and take it out from under car. Support suspension assembly so that it does not tilt and fall off jack.

CAUTION:

- a. When disconnecting brake tube, use suitable tube wrench. Never use open-end or adjustable wrench.
- b. Cover brake hose and tube openings to prevent entrance of dirt.

INSPECTION AND REPAIR

When the rear suspension has been removed, examine all parts for wear or damage. Particular attention should be given to bushing in suspension arms and bound bumper rubbers. Also check the condition of rubber insulators in the suspension member and the differential mounting.

Any of these components, if worn, can result in noise and vibration to the interior of car.

If necessary, replace differential mounting insulator.

Note:

- a. Mounting insulator of R200 differential carrier differs in dimension "B" from that of R180 differential carrier.
- b. When replacing, be sure to install differential mounting insulator with "U" mark facing upward.

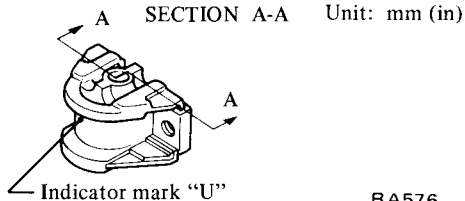
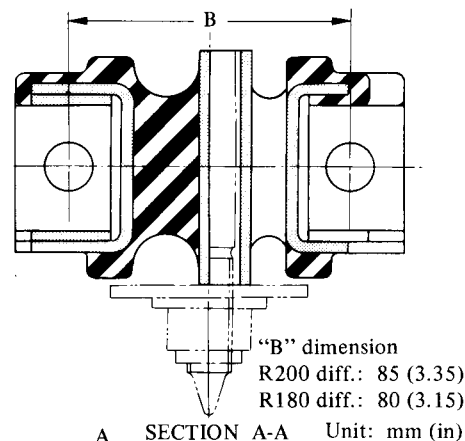

RA576

INSTALLATION

Install rear axle and suspension assembly in the reverse order of removal, noting the following points.

CAUTION:

When installing brake tubes, use Flare Nut Torque Wrench GG94310000.

1. Ensure suspension member and differential mounting insulator are correctly lined up.
2. When installing suspension member insulator, two slits in rubber insulators should be positioned in fore-and-after direction as shown below. Rubber insulators should be inserted from the underside of member.
3. Do not use lesser quality or substitute design parts.
4. Replace self-locking nuts at each removal.
5. Tightening torque values must be used as specified during reassembly to assure proper retention of parts.

CAUTION:

When reinstalling suspension member mounting bolt, make sure that bolt and tapered surface of collar are free from foreign material. Be sure to tighten lock nut **(A)** on body side to specification before tightening suspension member mounting lock nut **(1)**.

- (T)** : Propeller shaft to companion flange connecting nut
34 - 44 N·m
(3.5 - 4.5 kg·m,
25 - 33 ft-lb)
- Brake tube connector flare nut
15 - 18 N·m
(1.5 - 1.8 kg·m,
11 - 13 ft-lb)
- Shock absorber lower end fixing bolt
59 - 78 N·m
(6 - 8 kg·m,
43 - 58 ft-lb)
- Suspension member mounting lock nut **(1)**
78 - 98 N·m
(8 - 10 kg·m,
58 - 72 ft-lb)
- Suspension member mounting stay nut **(2)**
20 - 26 N·m
(2.0 - 2.6 kg·m,
14 - 19 ft-lb)
- Differential carrier mounting lock nut **(3)**

- 118 - 147 N·m
(12 - 15 kg·m,
87 - 108 ft-lb)
- Differential carrier to mounting insulator **(4)**
(R200 diff.)
88 - 118 N·m
(9 - 12 kg·m,
65 - 87 ft-lb)
(R180 diff.)
59 - 78 N·m
(6 - 8 kg·m,
43 - 58 ft-lb)
- Differential mounting bracket fixing nut **(5)**
59 - 78 N·m
(6 - 8 kg·m,
43 - 58 ft-lb)
- Differential mounting adapter plate bolt **(6)**
31 - 42 N·m
(3.2 - 4.3 kg·m,
23 - 31 ft-lb)

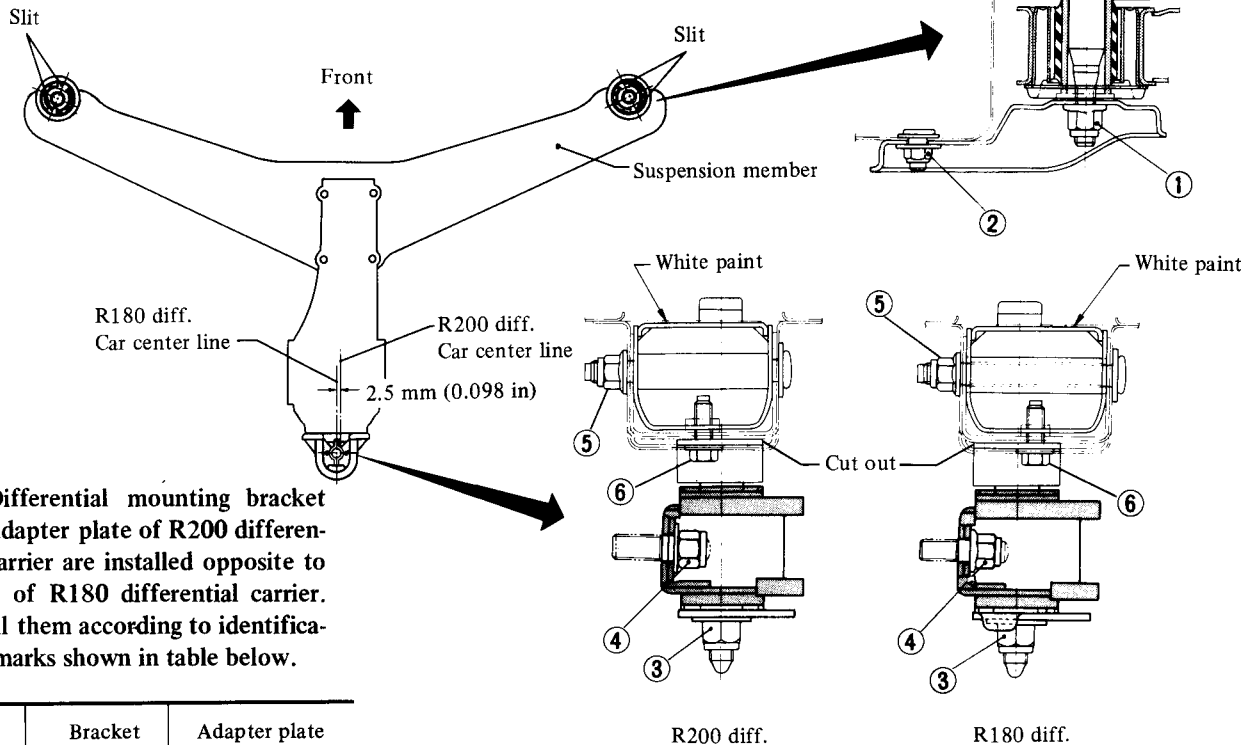

Note: Differential mounting bracket and adapter plate of R200 differential carrier are installed opposite to those of R180 differential carrier. Install them according to identification marks shown in table below.

	Bracket	Adapter plate
	White paint	Cutout
R200 diff.	Front	Rear
R180 diff.	Rear	Front

Tightening torque N·m (kg·m, ft-lb)

(A) : 118 - 157 (12 - 16, 87 - 116)

SUSPENSION MEMBER AND STABILIZER

REMOVAL

1. Block front wheels with chocks.
2. Raise the rear of car high enough to permit working underneath, and support it on safety stands. Place stands solidly under body member on both sides.
3. Support under center of differential carrier with a garage jack.
4. Disconnect brake tube ① and hand brake cable ② from suspension arm and member.

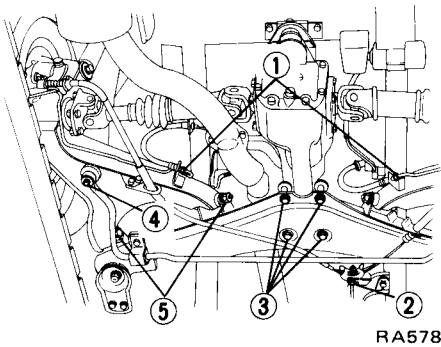

RA578

CAUTION:

- a. When disconnecting brake tube, use suitable tube wrench. Never use open-end or adjustable wrench.
- b. Cover brake hose and tube openings to prevent entrance of dirt.
- c. When disconnecting brake hose, be careful not to twist it while holding one side of it.

5. Disconnect differential gear carrier by removing bolts ③ at center of suspension member.
6. Remove stabilizer bar fixing bolt from suspension arm ④.
7. Disconnect suspension arms by removing suspension arm pins ⑤.
8. Disconnect suspension member from body by removing nuts at both ends of member.

9. Carefully lower jack with suspension member together with stabilizer, and take it out from under car. Support suspension assembly so that it does not tilt and fall off jack.
10. Remove stabilizer bar from suspension member by removing mounting clip bolts.

INSPECTION AND REPAIR

1. Check for evidence of deformation or cracks; if necessary, replace.
2. Check the rubber insulators of suspension member and mounting bushing of stabilizer for deterioration or cracks; if necessary, replace.

Replace rubber insulators of the suspension member using Rear Suspension Member Insulator Replacer KV40101300.

KV40101300

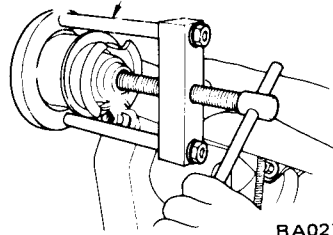

RA027

INSTALLATION

Install the rear suspension member and stabilizer in the reverse order of removal.

When installing, observe the following points:

1. Be sure to install stabilizer bushing with locating mark at outer side.
2. Install stabilizer mounting clip with arrow mark pointing to front.

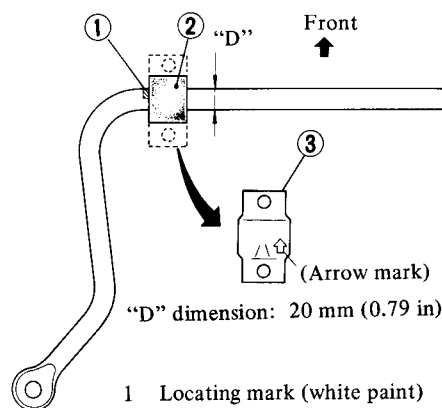

- 1 Locating mark (white paint)
- 2 Stabilizer bushing
- 3 Stabilizer mounting clip

RA579

3. Securely tighten stabilizer fixing bolt self-locking nut until it will no longer go.
4. Replace self-locking nuts at each removal.

CAUTION:

When installing brake tubes, use Flare Nut Torque Wrench GG94310000.

Note: Car weight must be on rear wheels when tightening suspension arm pins in order to clamp rubber bushings in a neutral or unloaded position.

Ⓣ : Brake tube connector flare nut

15 - 18 N·m
(1.5 - 1.8 kg·m,
11 - 13 ft·lb)

Differential gear carrier fitting nut

59 - 78 N·m
(6 - 8 kg·m,
43 - 58 ft·lb)

Suspension arm pin nut

78 - 98 N·m
(8 - 10 kg·m,
58 - 72 ft·lb)

Suspension member mounting lock nut

78 - 98 N·m
(8 - 10 kg·m,
58 - 72 ft·lb)

Suspension member mounting stay nut

20 - 25 N·m
(2 - 2.6 kg·m,
14 - 19 ft·lb)

Stabilizer bar fixing bolt

16 - 21 N·m
(1.6 - 2.1 kg·m,
12 - 15 ft·lb)

Stabilizer mounting clip bolt

16 - 21 N·m
(1.6 - 2.1 kg·m,
12 - 15 ft·lb)

Stabilizer mounting bracket nut

16 - 21 N·m
(1.6 - 2.1 kg·m,
12 - 15 ft·lb)

COIL SPRING AND SHOCK ABSORBER ASSEMBLY

REMOVAL

1. Block front wheels with chocks.
2. Raise the rear of car high enough to permit working underneath and until rear spring does not support car weight, and support it on safety stands. Place stands solidly under body member on both sides.
3. Open tail gate and turn cap at upper end of wheel house counter-clockwise.
4. Remove nuts securing shock absorber mounting insulator to body.

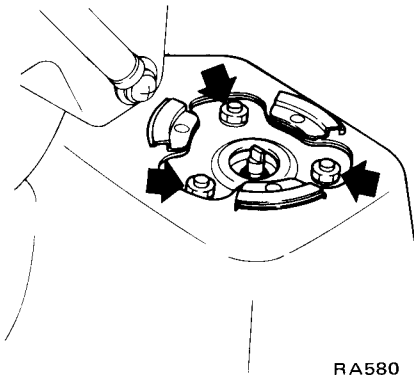

RA580

CAUTION:
Set Spring Compressor only on spring. Be careful so as not to damage shock absorber housing and piston rod.

3. Remove piston rod self-locking nut and washer. Release Spring Compressor ST35651001 and remove it from spring.
4. Take out bushing A, shock absorber mounting insulator, bushing B, bound bumper cover (dust cover) and bound bumper in that order.

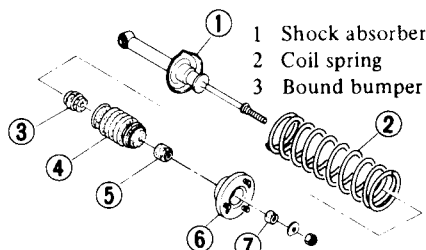

- 1 Shock absorber
- 2 Coil spring
- 3 Bound bumper
- 4 Bound bumper cover and dust cover assembly
- 5 Bushing B
- 6 Shock absorber mounting insulator
- 7 Bushing A

SRA238

5. Disconnect shock absorber by removing bolt at suspension arm.

DISASSEMBLY

1. Mark position of shock absorber mounting insulator and shock absorber lower end pin for proper reassembly.
2. Set up Spring Compressor ST35651001 on spring. Compress spring just far enough to permit turning of mounting insulator by hand.

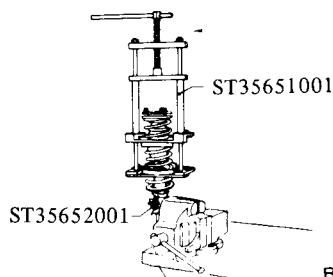

RA395

INSPECTION

Coil spring

1. Check coil spring for yield, deformation or cracks.
2. Test spring and compare with the specifications given in Service Data and Specifications.

Shock absorber

1. Test shock absorber and compare with the specification given in Service Data and Specifications. Replace if necessary.
2. Check for oil leakage and cracks. Also check piston rod for straightness.

Shock absorber mounting insulator

Replace if rubber and metal joints are melted or cracked.

Rubber parts

Check all rubber parts for wear, cracks, damage or deformation. Replace if necessary.

ASSEMBLY

Assemble spring and shock absorber assembly in the reverse order of disassembly, noting the following:

1. Correctly place coil spring in the lower spring seat. (Flat face of spring is top.)

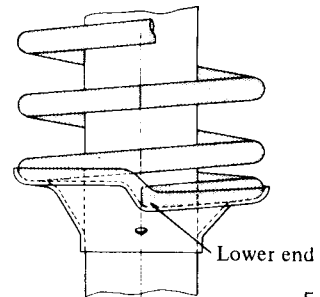

FA074

2. Make sure position of shock absorber mounting insulator and shock absorber lower end pin is correct.
3. Replace self-locking nut whenever it is removed.
4. Securely tighten piston rod self-locking nut until it will no longer go.

INSTALLATION

Install spring and shock absorber assembly in the reverse order of removal, noting the following:

Install top end of spring and shock absorber assembly first.

Ⓢ : Shock absorber mounting insulator to body nut

29 - 39 N·m
(3 - 4 kg·m,
22 - 29 ft·lb)

Shock absorber lower end fixing bolt

59 - 78 N·m
(6 - 8 kg·m,
43 - 58 ft·lb)

Piston rod nut

19 - 25 N·m
(1.9 - 2.6 kg·m,
14 - 19 ft·lb)

REAR AXLE

REAR AXLE SHAFT, WHEEL BEARINGS AND SEALS

REMOVAL AND DISASSEMBLY

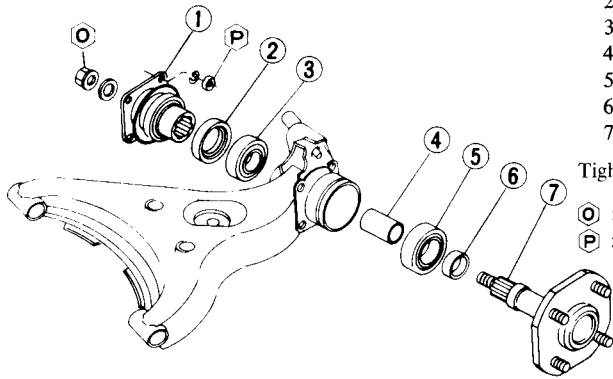

- 1 Companion flange
- 2 Grease seal
- 3 Inner wheel bearing
- 4 Distance piece
- 5 Outer wheel bearing
- 6 Bearing spacer
- 7 Rear axle shaft assembly

Tightening torque N·m (kg·m, ft·lb)

O : 245 - 324 (25 - 33, 181 - 239)

P : 49 - 59 (5 - 6, 36 - 43)

RA531

INSPECTION

Inspect the following parts. Replace or repair if necessary.

1. Check wheel bearing for end play and rolling surface for flaking, wear or seizure.
2. Check axle shaft for straightness, cracks, wear or distortion.
3. Check grease seal for cracks or deformation and seal lip for damage or wear.

ASSEMBLY AND INSTALLATION

Install in the reverse order of removal, noting the following points.

1. Clean wheel bearings, grease seal and the inside of axle shaft housing.
2. Wheel bearings are sealed type. When installing ensure that the sealed side of outer bearing faces the wheel and that the sealed side of inner bearing faces the differential.
3. When installing outer bearing to rear axle shaft, use Rear Axle Shaft Bearing Drift ST37750000.
4. A mark "N", "M", or "P" is stamped on bearing housing. Select a distance piece having a mark corresponding to the mark on bearing housing.

When a distance piece is reused, make sure that both ends are not collapsed or deformed.

1. Chock front wheels.
2. Loosen rear wheel nuts, jack up the rear of car and support it with safety stands.
3. Remove brake rotor and caliper assembly, referring to Section BR.
4. Disconnect drive shaft from axle shaft.
5. Remove wheel bearing lock nut using Rear Axle Stand KV40101000 and suitable bar.

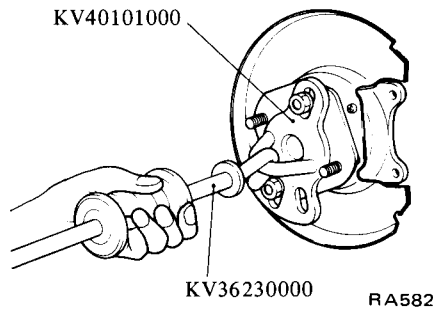

RA582

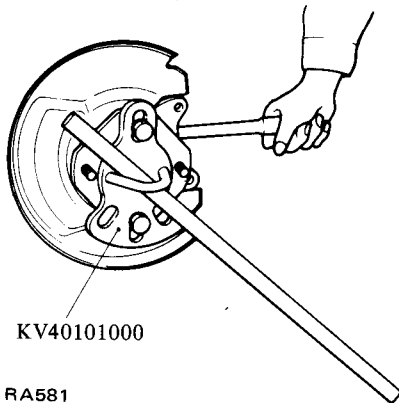

RA581

7. Remove companion flange.
8. Remove grease seal and inner bearing using Rear Axle Shaft Bearing Drift ST37750000.

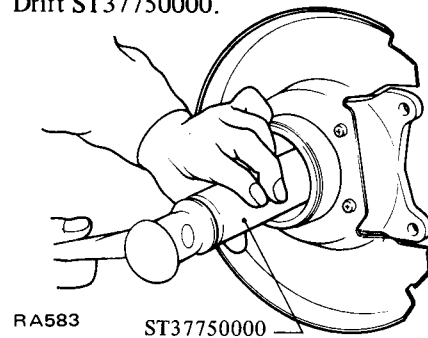

RA583

6. Draw out axle shaft using Rear Axle Stand KV40101000 and Sliding Hammer ST36230000. Remove rear axle shaft.

9. Withdraw outer bearing from rear axle shaft using a suitable bearing puller.

Note: Do not reuse bearings and grease seal after removal.

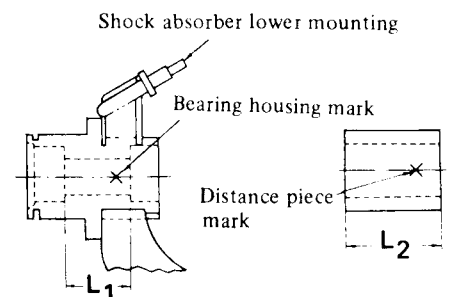

BEARING HOUSING DISTANCE PIECE

RA268

Rear bearing housing		Distance piece	
Mark	Size (L ₁ length) mm (in)	Mark	Size (L ₂ length) mm (in)
N	55.85 - 55.95 (2.1988 - 2.2028)	N	55.82 - 55.88 (2.1976 - 2.2000)
M	55.95 - 56.05 (2.2028 - 2.2067)	M	55.92 - 55.98 (2.2016 - 2.2039)
P	56.05 - 56.15 (2.2067 - 2.2106)	P	56.02 - 56.08 (2.2055 - 2.2079)

5. Fill recommended multi-purpose grease to the portions indicated by asterisk (*) as shown below.

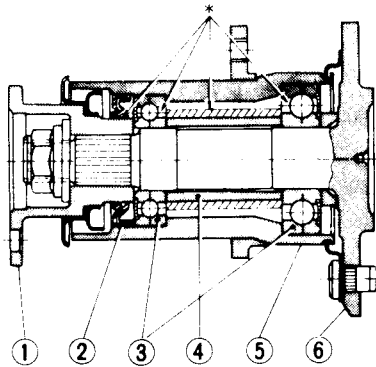

- 1 Companion flange
- 2 Grease seal
- 3 Wheel bearing
- 4 Distance piece
- 5 Bearing housing
- 6 Rear axle shaft

RA399

6. Install grease seal by Rear Axle Grease Seal Drift ST37710000.

7. Tighten new wheel bearing lock nut and measure the preload and rear axle shaft end play. If the correct preload or end play cannot be obtained, disassemble again and replace distance piece.

Ⓣ : Wheel bearing lock nut

245 - 324 N·m
(25 - 33 kg·m,
181 - 239 ft·lb)

Wheel bearing preload
0.69 N·m (7.0 kg·cm,
6.1 in·lb) or less

At the hub bolt
11.8 N (1.2 kg,
2.6 lb) or less

Rear axle shaft end play
Less than 0.3 mm (0.012 in)

8. Caulk wheel bearing lock nut securely after checking preload and end play.

SUSPENSION ARM REMOVAL

1. Chock front wheels.
2. Loosen wheel nuts, jack up the rear of car and support it with safety stands.
3. Disconnect brake tube ① from brake hose and wheel cylinder, remove brake tube from suspension arm.
4. Disconnect hand brake cable ② from caliper assembly and remove hand brake cable from suspension arm.
5. Disconnect drive shaft ③ from axle shaft.
6. Remove stabilizer bar bolt ④.

CAUTION:

- a. When disconnecting brake tube, use suitable tube wrench. Never use open-end or adjustable wrench.
- b. Cover brake hose and tube openings to prevent entrance of dirt.

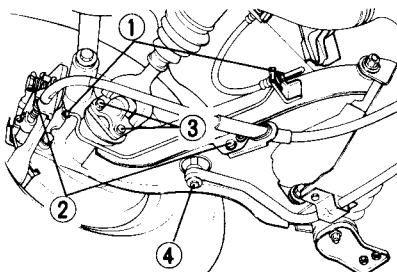

RA584

7. Remove brake rotor and caliper assembly, referring to Section BR.
8. Remove rear axle shaft, wheel bearings and grease seal. Refer to Rear Axle for removal and disassembly.
9. Disconnect shock absorber at lower end.
10. Disconnect suspension arm by removing suspension arm pins securing suspension arm to suspension member.

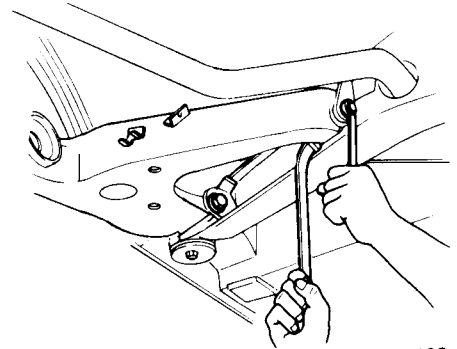

RA402

11. Draw out rubber bushings from suspension arm using Rear Suspension Arm Bushing Remover ST38280000.

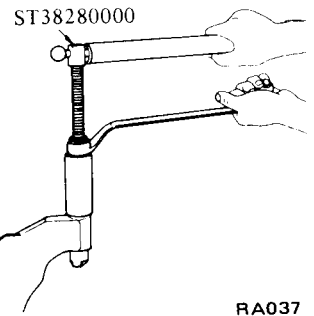

RA037

INSPECTION

1. Examine suspension arms to ensure they are not deformed or cracked.
2. Check rubber bushings for wear, damage or separation. Replace if necessary.

INSTALLATION

Install in the reverse order of removal, noting the following points:

1. Replace self-locking nuts at each removal.
2. Finally tighten suspension arm pin nut to specifications after install-

ing wheels and placing car on ground under the curb weight in order to clamp rubber bushings in a neutral position.

3. Adjust parking brake cable. Refer to Hand Brake (Section MA) for adjustment.
4. Bleed air from brake system. Refer to Bleeding Hydraulic System (Section BR).

ⓧ : Brake tube connector flare nut

15 - 18 N·m
(1.5 - 1.8 kg-m,
11 - 13 ft-lb)

Brake baffle plate
3.1 - 4.3 N·m
(0.32 - 0.44 kg-m,
2.3 - 3.2 ft-lb)

Brake caliper
38 - 52 N·m
(3.9 - 5.3 kg-m,
28 - 38 ft-lb)

Wheel bearing lock nut
245 - 324 N·m
(25 - 33 kg-m,
181 - 239 ft-lb)

Drive shaft flange yoke nut
49 - 59 N·m
(5 - 6 kg-m,
36 - 43 ft-lb)

Suspension arm pin nut
78 - 98 N·m
(8 - 10 kg-m,
58 - 72 ft-lb)

Stabilizer bar fixing or mounting bolts
16 - 21 N·m
(1.6 - 2.1 kg-m,
12 - 15 ft-lb)

DRIVE SHAFT (Cardan universal joint type)

REMOVAL

1. Chock front wheels.
2. Jack up rear of car and support on safety stands.

3. Side Flange type (R200 diff.);
Remove drive shaft universal joint yoke flange bolts and nuts from both sides.

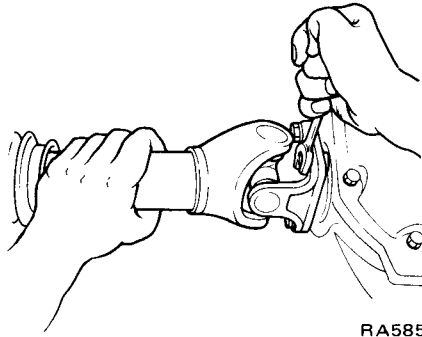

Pre-disassembly inspection

1. Visually inspect parts for wear, deformation or damage.
2. Stroke drive shaft to see if it moves smoothly.
3. Check play in drive shaft. If the play exceeds 0.2 mm (0.008 in), replace drive shaft assembly.

Note: Measurement should be taken with drive shaft fully compressed.

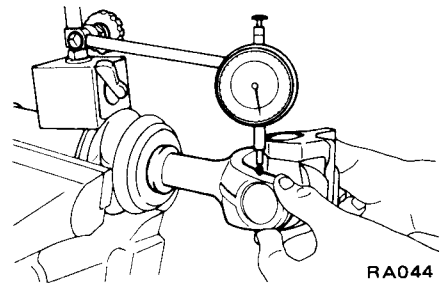

4. Side Yoke type (R180 diff.);
Disconnect drive shaft on the wheel side.
Remove side yoke fitting bolts, and extract side yokes together with drive shafts.

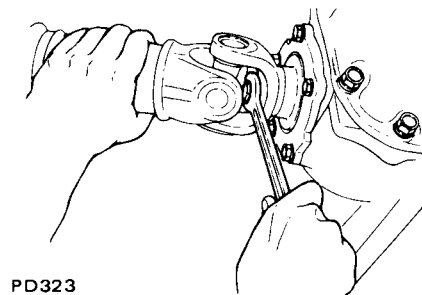

4. Check movement of spider journal. If journal does not move smoothly, disassemble and replace journal.
5. Check journal axial play. If the play exceeds 0.02 mm (0.0008 in), adjust or replace as required.

DISASSEMBLY

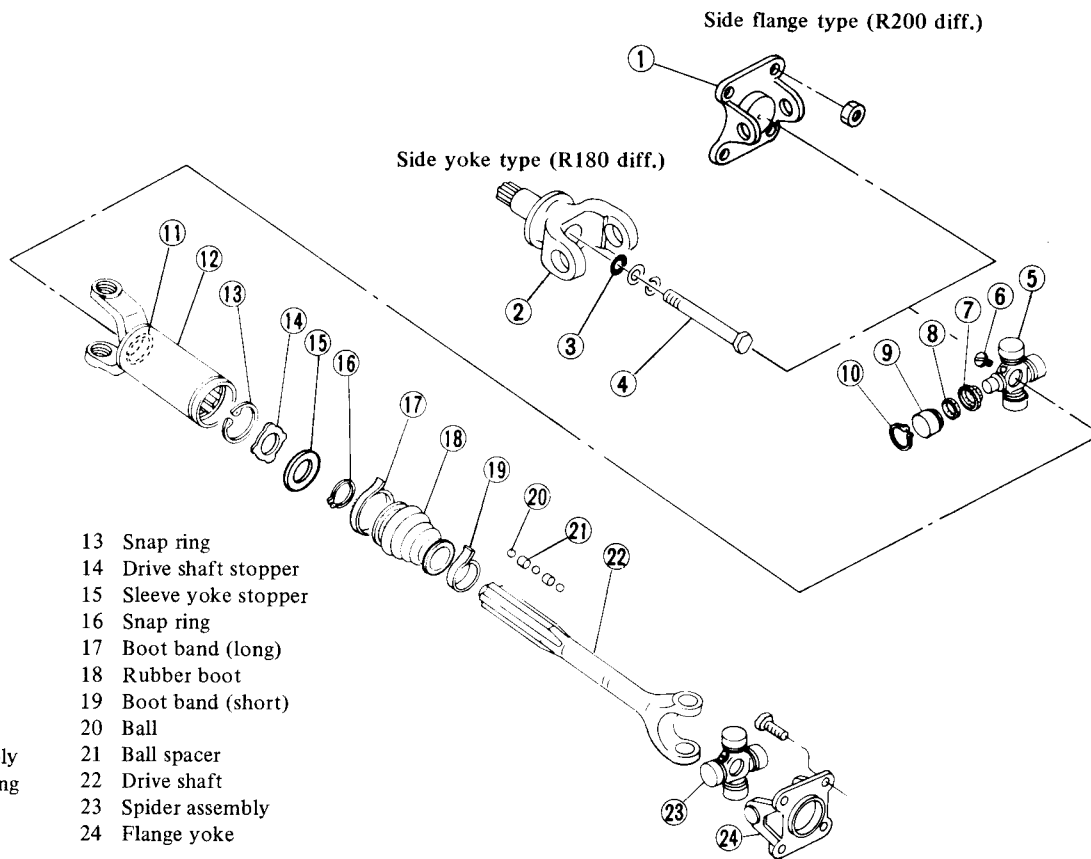

- | | |
|---------------------------|------------------------|
| 1 Yoke flange | 13 Snap ring |
| 2 Side yoke | 14 Drive shaft stopper |
| 3 O-ring | 15 Sleeve yoke stopper |
| 4 Side yoke bolt | 16 Snap ring |
| 5 Spider journal | 17 Boot band (long) |
| 6 Filler plug | 18 Rubber boot |
| 7 Dust cover | 19 Boot band (short) |
| 8 Oil seal | 20 Ball |
| 9 Bearing race assembly | 21 Ball spacer |
| 10 Bearing race snap ring | 22 Drive shaft |
| 11 Sleeve yoke plug | 23 Spider assembly |
| 12 Sleeve yoke | 24 Flange yoke |

RA586

1. Mark relationship across propeller shaft and journal so that the original combination is restored at assembly.
2. Remove snap ring with a standard screwdriver.
3. Lightly tap base of yoke with a hammer, and withdraw bearing race.
4. Cut boot band and remove boot from sleeve yoke.
5. Remove snap ring from sleeve yoke using suitable snap ring plier.
6. Withdraw drive shaft carefully from sleeve yoke so as not to lose balls and spacers.

4. Check journal pin for dent or brinell marks, and yoke hole for sign of wear or damage.

Snap ring, bearing, grease seal and dust seal should also be inspected to see if they are damaged, worn or deformed. Replace as required.

Note: Sleeve yoke, balls, spacers and drive shaft are not available as service parts. Therefore, if any wear or damage exists in above parts, drive shaft must be replaced as an assembly.

ASSEMBLY

Assemble drive shaft in the reverse order of disassembly, noting the following:

1. Thoroughly remove used grease from sleeve yoke, drive shaft ball rolling grooves and grease grooves, and clean them.
2. Align the yokes and ensure that steel balls and spacers are fitted in the correct sequence.
3. Apply an adequate quantity of multi-purpose grease to the ball rolling groove and grease groove, approximately 10 g (0.35 oz). In addition, apply 35 g (1.23 oz) of grease to the area shown below.

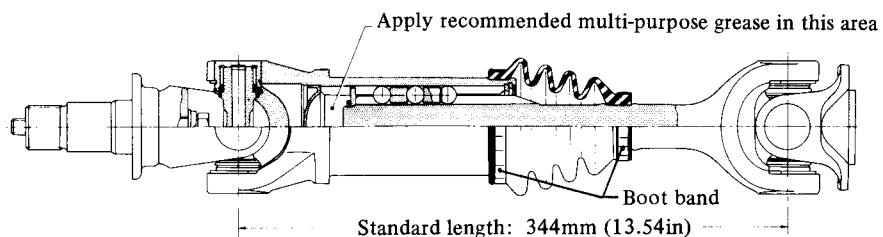

INSPECTION

1. Replace boot and O-ring of side yoke, if damaged.
2. Check drive shaft for straightness, cracks, damage, wear or distortion. Replace drive shaft assembly as required.
3. Check steel balls and sleeve yoke for damage, wear or distortion. Replace drive shaft assembly as required.

RA404

4. Check the drive shaft play. Refer to Drive Shaft for pre-disassembly inspection.
5. Adjust distance between spider journals to standard length of 344 mm (13.54 in). Cover sleeve yoke with boot and secure with boot band.
6. Selecting a suitable snap ring, adjust the axial play of universal joint to within 0.02 mm (0.0008 in). Snap rings of seven different thicknesses are available. Refer to Service Data and Specifications.

⊕ : 31 - 42 N·m
(3.2 - 4.3 kg·m,
23 - 31 ft·lb)

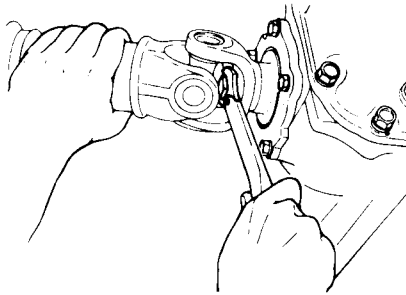

PD324

3. Extract drive shaft from differential carrier by prying it with a suitable steel bar.

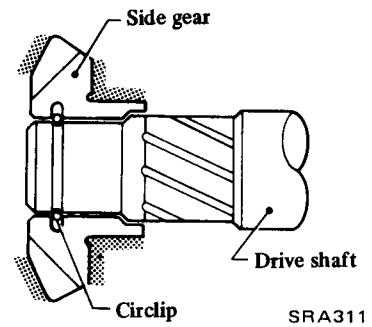

SRA311

Note: Two opposite snap rings should be equal in thickness.

INSTALLATION

1. Side Flange type (R200 diff.);
Install drive shaft universal joint yoke flange bolts and nuts on both sides, and tighten yoke flange bolts and nuts to specified torque using torque wrench.

⊕ : 49 - 59 N·m
(5 - 6 kg·m,
36 - 43 ft·lb)

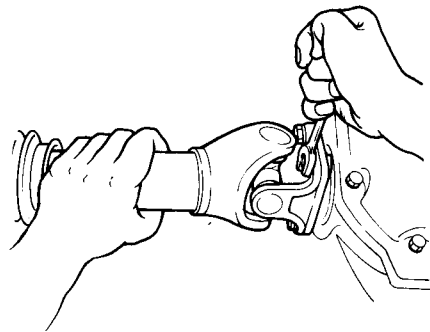

RA585

2. Side Yoke type (R180 diff.);
Install side yoke together with drive shafts to differential gear carrier assembly, and tighten side yoke fitting bolts to specified torque using torque wrench.

CAUTION:
Be careful not to damage side yoke and oil seal when installing.

3. Join drive shafts with rear axle flanges and tighten connecting bolts to specified torque.

⊕ : 49 - 59 N·m
(5 - 6 kg·m,
36 - 43 ft·lb)

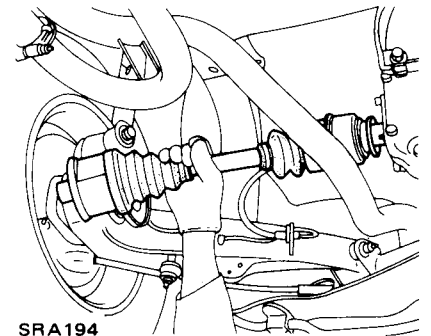

SRA194

4. Install in reverse order of removal, noting the following points.

CAUTION:
Be careful not to damage oil seal and either end of drive shaft when installing.

DRIVE SHAFT (Tripod universal joint type)

REMOVAL AND INSTALLATION

1. Block front wheels.
2. Disconnect drive shaft on the wheel side.

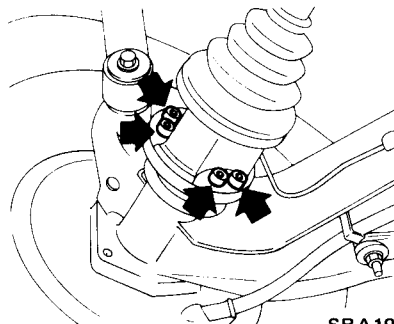

SRA193

⊕ : Drive shaft to companion flange fixing bolt
27 - 37 N·m
(2.8 - 3.8 kg·m,
20 - 27 ft·lb)

DISASSEMBLY

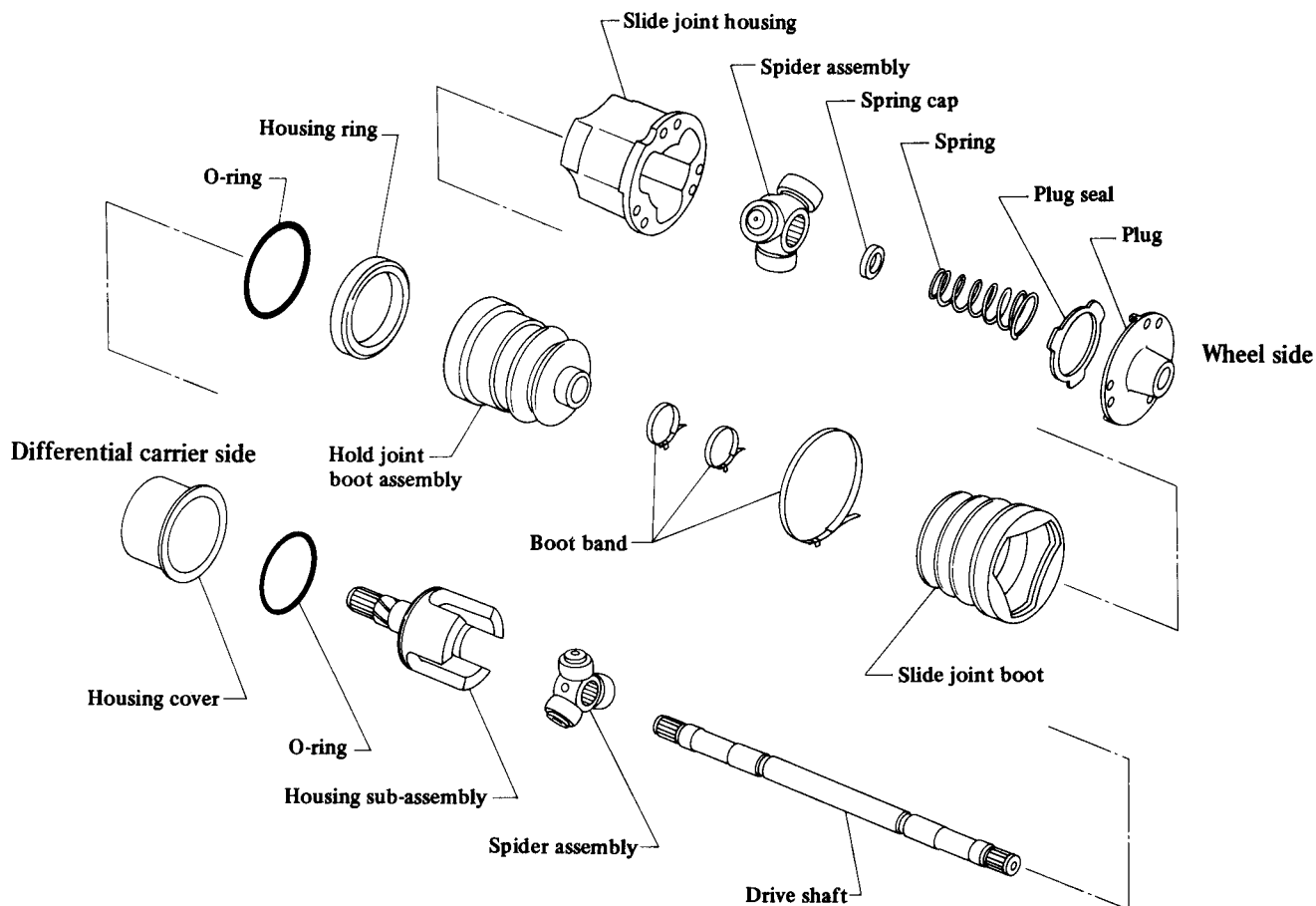

SRA333

Wheel side

1. Place “soft” jaws over steel jaws of bench vise, and place drive shaft securely in vise.
2. Remove plug.

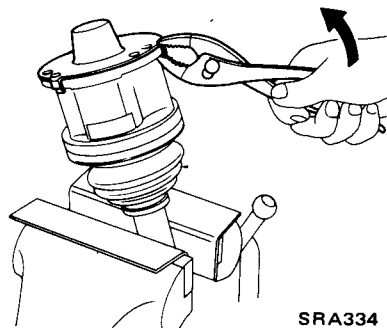

SRA334

4. Remove boot bands.

Do not reuse boot bands once they have been removed.

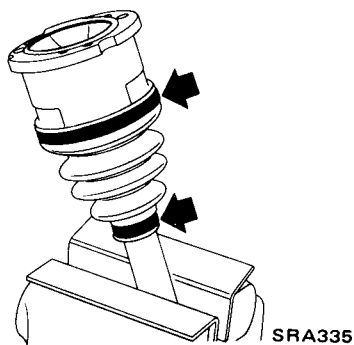

SRA335

Differential carrier side

1. Snugly place drive shaft assembly in a vise.

Be careful not to damage drive shaft assembly by forcing it into place.

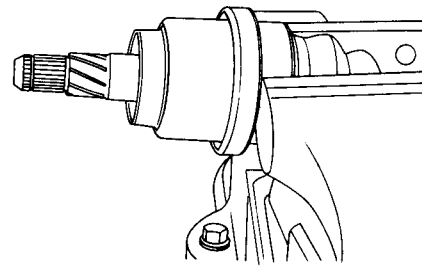

SRA336

3. Remove plug seal, spring and spring cap.

5. Remove spider assembly.
Refer to Spider Assembly for disassembly.
6. Draw out slide joint boot.

2. Cut off hold joint boot assembly with a metal saw blade and remove housing sub-assembly.

- When cutting off hold joint boot assembly, ensure that drive shaft is pushed into housing sub-assembly to prevent spider assembly from being scratched.
- Do not reuse hold joint boot assembly once it has been removed.

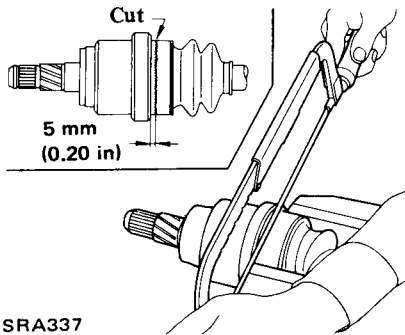

SRA337

3. Remove boot band.

Do not reuse boot band once it has been removed.

4. Remove spider assembly.

Refer to Spider Assembly for disassembly.

5. Cut off remaining part of hold joint boot assembly with a metal saw blade and remove it from housing sub-assembly.

- Be careful not to scratch housing sub-assembly.
- Be careful not to scratch housing ring excessively.

CAUTION:

Housing ring is selected to suit outside diameter of housing sub-assembly. Do not attempt to change original combination when replacing parts.

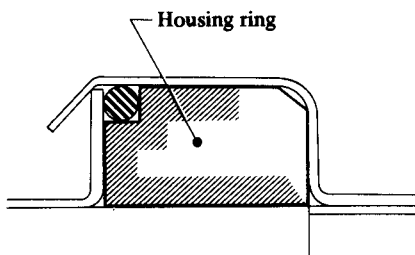

 : Surface where there must be no scratches
 SRA338

6. Remove housing cover.

Do not reuse housing cover once it has been removed.

7. Remove O-ring.

Do not reuse O-ring once it has been removed.

8. Remove housing ring.
9. Draw out hold joint boot.

Spider assembly

CAUTION:

The spider assembly is a non-disassembling type, consisting of a tripod, rollers, needle bearing and washer.

1. Make matching mark.

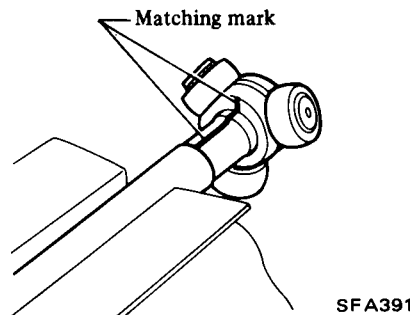

SFA391

2. Detach spider assembly using a press.

- Do not attempt to directly touch contact surface of drive shaft end at spring cap or housing sub-assembly. Use a suitable tool.
- To prevent drive shaft from dropping, always support drive shaft by hand when removing spider assembly.

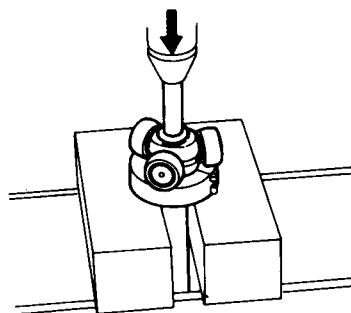

SFA392

INSPECTION

Thoroughly clean all parts in cleaning solvent, and dry with compressed air. Check parts for evidence of deformation or other damage.

Drive shaft

1. Replace drive shaft assembly if drive shaft is twisted or cracked.
2. Replace drive shaft if it is deformed or damaged.

Spider assembly

1. Replace spider assembly if needle bearing and washer are damaged.
2. Check to see if serrated portions are deformed; also check serrated portions on the drive shaft side. If necessary, replace.
3. Check to see if roller surfaces are scratched, worn or damaged; also check housing sub-assembly for abnormalities. If necessary, replace.

Boot, boot band and O-ring

1. Replace boot if it is cracked or torn.
2. Do not reuse boot bands and O-rings after they have been removed.

Other component parts

Replace other parts if deformed or damaged.

ASSEMBLY

- After drive shaft has been assembled, ensure that it moves smoothly over its entire range without binding.
- Use NISSAN GENUINE GREASE or equivalent after every overhaul.

Differential carrier side

1. Attach housing ring, O-ring, housing sub-assembly and housing cover to a new hold joint boot assembly and place assembled unit flange on a vise.

- Do not place any other part of assembled unit on a vise.
- Apply a coat of grease to O-ring.

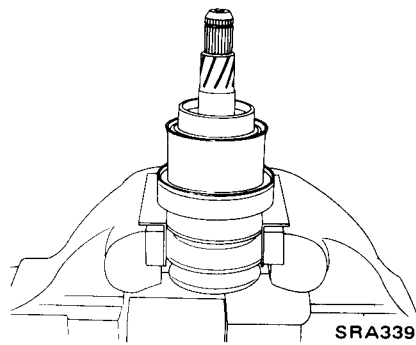

2. Bend the edge over along the entire circumference.
- Bend the edge at two positions (180° apart) and ensure that housing cover does not rattle.
- Place a board on housing cover to prevent it from being scratched.

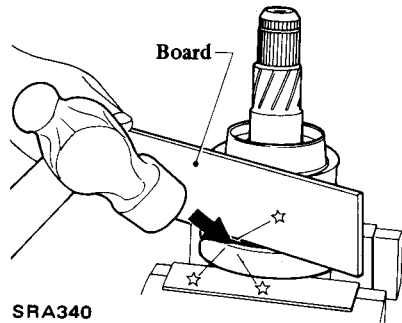

8. Place hold joint boot assembly so that its flange in vise.
- Do not place any other part of hold joint boot assembly on a vise.

9. Insert housing sub-assembly into place.
10. Bend the edge over along the entire circumference.

- Bend the edge at two positions (180° apart) and ensure that housing sub-assembly does not rattle.
- Place a board on housing sub-assembly to prevent it from being scratched.

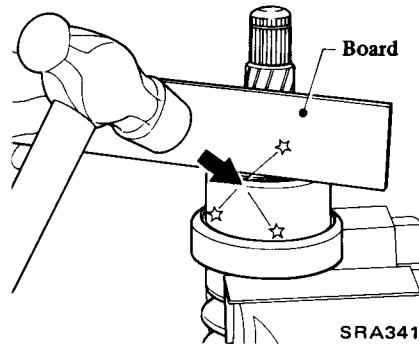

11. Apply sealant.

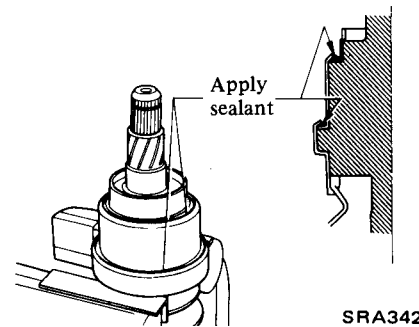

12. Set boot so that it does not swell or deform when its length is "L".

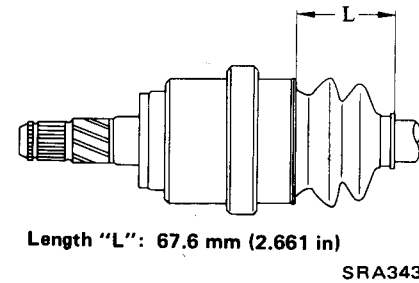

13. Install boot band.

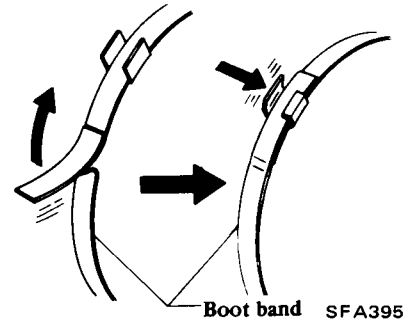

Wheel side

1. Insert new boot bands, slide joint boot and slide joint housing to drive shaft.

Be careful not to scratch boot with drive shaft end.

2. Install spider assembly. Refer to Spider Assembly for assembly.
3. Install large diameter boot band.

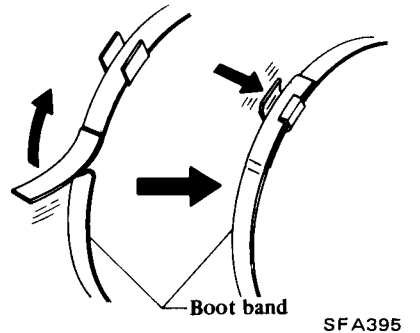

4. Pack with grease. Specified amount of grease: Approx. 175 g (6.17 oz)
5. Install spring cap, spring and plug seal.
6. Secure plugs using dummy bolts and lock plug by bending plug.
7. Set boot so that it does not swell or deform when its length is "L".

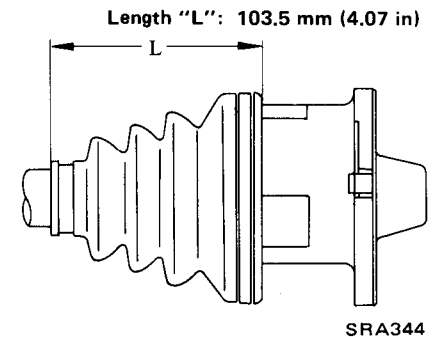

8. Install smaller diameter boot band.

Spider assembly

1. Place drive shaft in a vise, using soft cushioning pads.
2. Install spider assembly securely, ensuring marks are properly aligned.

- If there is no mark, position both spider assemblies (one on the wheel side and the other on the differential carrier side) so that their phases are nearly 180°.
- Press-fit with spider assembly serration chamfer facing shaft.

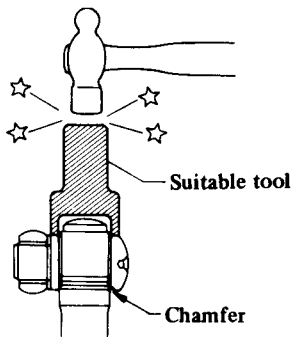

SFA397

3. Stake serration portion evenly at three places.

- Avoid areas which have been previously staked.

- Always stake two or three teeth at a place where staked gap is more than 1 mm (0.04 in).

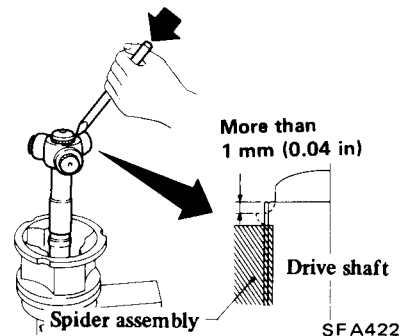

SFA422

SERVICE DATA AND SPECIFICATIONS (S.D.S.)

GENERAL SPECIFICATIONS

Items		Models	
		S130	S130J GS130(J)
Suspension type		Independent rear suspension	
Coil spring	Wire diameter	mm (in)	11.8 (0.465)
	Coil diameter	mm (in)	100 (3.94)
	Free length	mm (in)	358.3 (14.11) 367.2 (14.46)
	Spring constant	N/mm (kg/mm, lb/in)	22.07 (2.25, 126.0)
	Identification color		Orange 1 & Orange 2 Pink 1 & Orange 2

Shock absorber	Maximum length "L"	mm (in)	537.3 (21.15)
	Stroke	mm (in)	175 (6.89)
Stabilizer bar	Bar diameter	mm (in)	20 (0.79)

Shock absorber maximum length "L" RA419

INSPECTION AND ADJUSTMENT

WHEEL ALIGNMENT (Unladen)

Camber	degree	-5' - 1°25'
Toe-in	mm (in)	0 - 2 (0 - 0.08)

SHOCK ABSORBER

Damping force at 0.3 m (1.0 ft)/s		
Expansion	N (kg, lb)	1,373 (140, 309)
Compression	N (kg, lb)	441 (45,99)

REAR AXLE

Turning torque	N-m (kg-cm, in-lb)	Less than 0.69 (7.0, 6.1) [11.8 N (1.2 kg, 2.6 lb) at hub bolt]
End play	mm (in)	Less than 0.3 (0.012)

DRIVE SHAFT (Cardan universal joint type)

Radial play of ball spline	mm (in)	Less than 0.2 (0.008)
Axial play of spider journal	mm (in)	Less than 0.02 (0.0008)
Journal swinging torque	N-m (kg-cm, in-lb)	Less than 1.0 (10, 8.7)

Thickness of spider journal adjusting snap ring.

Thickness mm (in)	Identification color
1.49 (0.0587)	White
1.52 (0.0598)	Yellow
1.55 (0.0610)	Red
1.58 (0.0622)	Green
1.61 (0.0634)	Blue
1.64 (0.0646)	Light brown
1.67 (0.0657)	Black

TIGHTENING TORQUE

Unit	N-m	kg-m	ft-lb
Brake tube connector flare nut	15 - 18	1.5 - 1.8	11 - 13
Brake caliper	38 - 52	3.9 - 5.3	28 - 38
Brake baffle plate	3.1 - 4.3	0.32 - 0.44	2.3 - 3.2
Propeller shaft to companion flange connecting nut	34 - 44	3.5 - 4.5	25 - 33
Wheel bearing lock nut	245 - 324	25 - 33	181 - 239
Drive shaft installation bolts			
Gear carrier side (R200 diff.)	49 - 59	5 - 6	36 - 43
Gear carrier side (R180 diff.)	31 - 42	3.2 - 4.3	23 - 31
Wheel side	49 - 59	5 - 6	36 - 43
Shock absorber mounting insulator to body nut	29 - 39	3 - 4	22 - 29
Shock absorber lower end fixing bolt	59 - 78	6 - 8	43 - 58
Shock absorber piston rod nut	19 - 25	1.9 - 2.6	14 - 19
Suspension member mounting lock nut	78 - 98	8 - 10	58 - 72
Suspension member mounting stay nut	20 - 25	2.0 - 2.6	14 - 19
Differential gear carrier fitting nut	59 - 78	6 - 8	43 - 58
Differential carrier mounting lock nut	118 - 147	12 - 15	87 - 108
Differential carrier to mounting insulator (R200 diff.)	88 - 118	9 - 12	65 - 87
(R180 diff.)	59 - 78	6 - 8	43 - 58
Differential mounting bracket fixing nut	59 - 78	6 - 8	43 - 58
Differential mounting adapter plate bolt	31 - 42	3.2 - 4.3	23 - 31
Suspension arm pin nut	78 - 98	8 - 10	58 - 72
Stabilizer bar fixing bolt	16 - 21	1.6 - 2.1	12 - 15
Stabilizer mounting clip bolt	16 - 21	1.6 - 2.1	12 - 15
Stabilizer mounting bracket nut	16 - 21	1.6 - 2.1	12 - 15
Wheel nut	78 - 98	8 - 10	58 - 72

TROUBLE DIAGNOSES AND CORRECTIONS

When rear axle and suspension is suspected of being noisy it is advisable to make thorough test to determine whether the noise originates in the tires, road surface,

exhaust, propeller shaft, engine, transmission, universal joint, wheel bearings or suspension.

Noise which originates in other places cannot be corrected by adjust-

ment or replacement of parts in the rear axle and rear suspension.

In case of oil leak, first check if there is any damage or restriction in breather.

Condition	Probable cause	Corrective action
<p>Noise (unusual sound)</p>	<p>Loose wheel nuts. One or more securing bolts loose. Lack of lubricating oil or grease. Faulty shock absorber. Incorrect adjustment of rear axle shaft end play. Damaged or worn wheel bearing. Worn spline portion of rear axle shaft. Loose journal, connections, etc. Unbalance of wheel and tire. Damage of the rubber parts such as suspension arm bush, shock absorber mounting bush, differential mounting plate rubber. Deformed differential mounting insulator. Faulty universal joints. Worn or damaged rear suspension member mounting insulator. Worn or seized sliding portion of drive shaft ball spline. Breakage of coil spring.</p>	<p>Tighten. Tighten to specified torque. Lubricate as required. Replace. Adjust. Replace. Replace if necessary. Tighten to torque. Balance. Replace damaged parts. Replace. Adjust or replace. Replace. Replace drive shaft assembly. Replace.</p>
<p>Instability in driving This problem is also related to the front suspension. For trouble diagnosis, also refer to the FA section.</p>	<p>Loose wheel nuts. Worn shock absorber. Incorrect wheel alignment. 1) Coil spring wear. 2) Worn-out drive shaft ball spline. Damaged rear suspension arm rubber bushing, suspension member insulator, differential mounting insulator.</p>	<p>Tighten to specified torque. Replace. Replace. Replace. Replace drive shaft assembly.</p>
<p>Oil leakage</p>	<p>Damaged oil seal on rear axle shaft. Oil leakage from the differential carrier. Damaged dust cover of drive shaft. Damaged grease seal of rear axle shaft.</p>	<p>Replace. Replace parts as required. Replace. Replace.</p>

SPECIAL SERVICE TOOLS

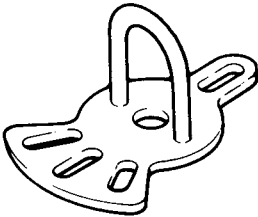
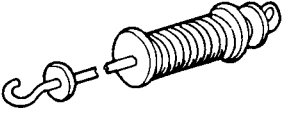
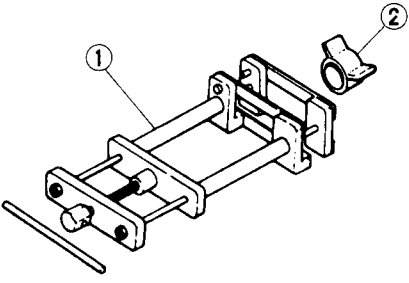
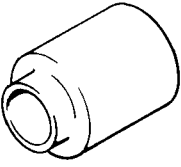
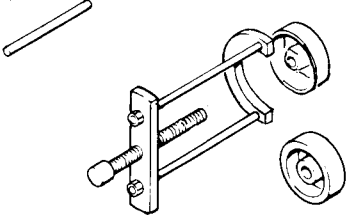
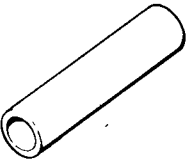
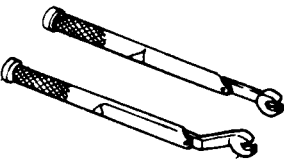
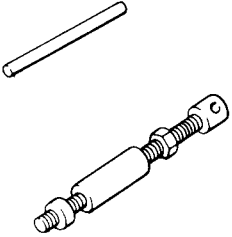
Tool number & tool name	Kent-Moore No.	Tool number & tool name	Kent-Moore No.
	Reference page		Reference page
KV40101000 Rear axle stand 	J 25604-01	ST3565S001 Coil spring compressor set ① ST35651001 Spring compressor ② ST35652001 Clamp	J 25833
	Page RA-7		Page RA-6
ST36230000 Sliding hammer 	J 25840		
	Page RA-7		
ST37710000 Rear axle grease seal drift 	J 25861	KV40101300 Rear suspension member insulator replacer 	—
	Page RA-8		Page RA-5
ST37750000 Rear axle shaft bearing drift 	J 25862	GG94310000 Flare nut torque wrench 	—
	Page RA-7		Page RA-3 Page RA-5
ST38280000 Rear suspension arm bushing remover 	J 25871		
	Page RA-8		