

# PROPELLER SHAFT & DIFFERENTIAL CARRIER

## SERVICE DATA

### CONTENTS

<b>PROPELLER SHAFT</b> .....	PD- 2	DIFFERENTIAL CASE .....	PD-14
INSPECTION .....	PD- 2	INSPECTION .....	PD-15
REMOVAL .....	PD- 2	ASSEMBLY AND ADJUSTMENT .....	PD-15
INSTALLATION .....	PD- 2	PRECAUTIONS IN REASSEMBLY.....	PD-15
CHECKING AND CORRECTING		ASSEMBLY OF DIFFERENTIAL GEAR	
UNBALANCED PROPELLER SHAFT .....	PD- 2	CASE .....	PD-15
<b>DIFFERENTIAL CARRIER</b>		ADJUSTMENT OF DRIVE PINION	
<b>(Type R180)</b> .....	PD- 3	PRELOAD .....	PD-16
REMOVAL .....	PD- 3	ADJUSTMENT OF DRIVE PINION	
PRE-DISASSEMBLY INSPECTION .....	PD- 4	HEIGHT .....	PD-16
DISASSEMBLY .....	PD- 4	ADJUSTMENT OF SIDE BEARING	
DIFFERENTIAL CASE .....	PD- 4	WASHERS .....	PD-17
INSPECTION .....	PD- 5	INSTALLATION .....	PD-20
ASSEMBLY AND ADJUSTMENT .....	PD- 5	REPLACEMENT OF OIL SEALS .....	PD-20
PRECAUTIONS IN REASSEMBLY .....	PD- 5	FRONT OIL SEAL .....	PD-20
ASSEMBLY OF DIFFERENTIAL GEAR		SIDE OIL SEAL .....	PD-20
CASE .....	PD- 5	<b>SERVICE DATA AND</b>	
ADJUSTMENT OF DRIVE PINION		<b>SPECIFICATIONS (S.D.S.)</b> .....	PD-21
PRELOAD .....	PD- 6	PROPELLER SHAFT .....	PD-21
ADJUSTMENT OF DRIVE PINION		GENERAL SPECIFICATIONS .....	PD-21
HEIGHT .....	PD- 7	SERVICE DATA .....	PD-21
ADJUSTMENT OF SIDE RETAINER		TIGHTENING TORQUE .....	PD-21
SHIMS .....	PD- 8	DIFFERENTIAL CARRIER .....	PD-21
INSTALLATION .....	PD-10	GENERAL SPECIFICATIONS .....	PD-21
REPLACEMENT OF OIL SEAL .....	PD-10	SERVICE DATA .....	PD-22
FRONT OIL SEAL .....	PD-10	TIGHTENING TORQUE .....	PD-23
SIDE OIL SEAL .....	PD-11	<b>TROUBLE DIAGNOSES AND</b>	
<b>DIFFERENTIAL CARRIER</b>		<b>CORRECTIONS</b> .....	PD-24
<b>(Type R200)</b> .....	PD-12	PROPELLER SHAFT .....	PD-24
REMOVAL .....	PD-12	DIFFERENTIAL CARRIER .....	PD-24
PRE-DISASSEMBLY INSPECTION .....	PD-13	<b>SPECIAL SERVICE TOOLS</b> .....	PD-26
DISASSEMBLY .....	PD-13		

## PROPELLER SHAFT

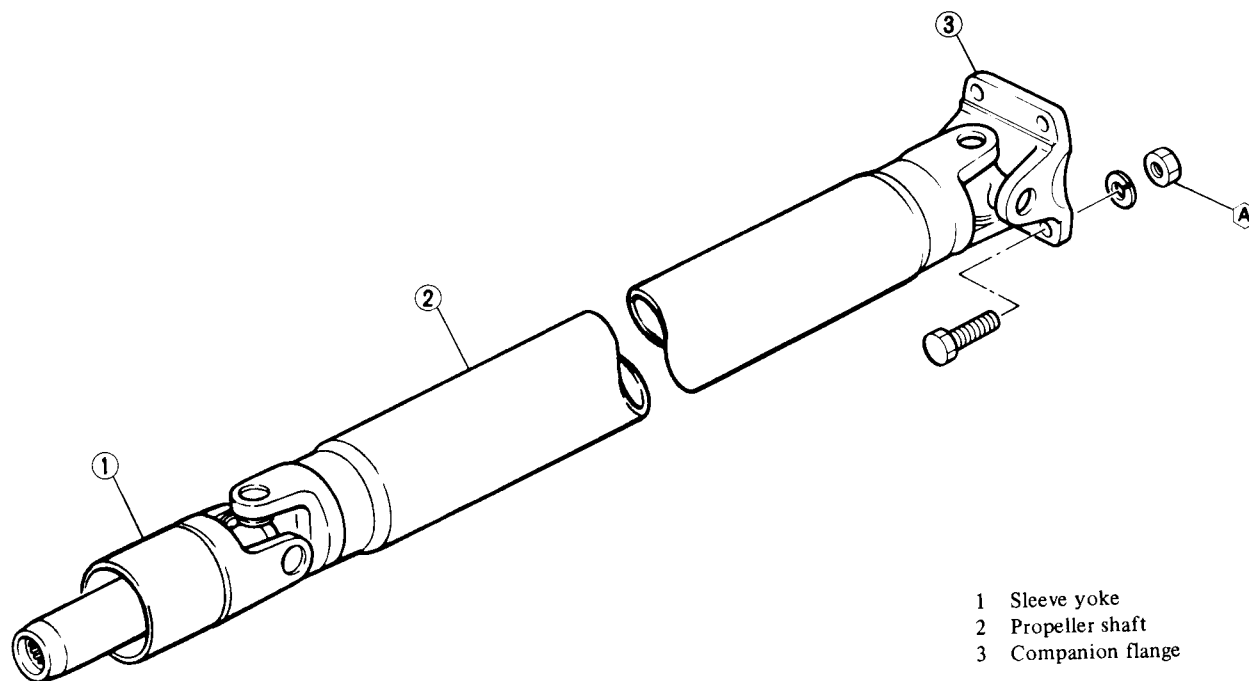

- 1 Sleeve yoke
- 2 Propeller shaft
- 3 Companion flange

Tightening torque N·m (kg·m, ft·lb)  
 (A) : 34 - 44 (3.5 - 4.5, 25 - 33)

PD427

Fig. PD-1 Propeller Shaft

### INSPECTION

1. Check journal for axial play. If play exists, replace propeller shaft assembly.

**Note:** Journal cannot be disassembled.

2. Check the propeller shaft tube surface for dents or cracks. If necessary, replace propeller shaft assembly.

### REMOVAL

1. Raise car on hoist.

Remove front exhaust tube and heat shield plate to free them from car body. (Only for California model)

2. Scribe match marks both on propeller shaft and companion flange so that shaft can be reinstalled in the original position.

3. Remove bolts securing shaft to companion flange.

4. Draw out propeller shaft sleeve yoke from transmission by moving shaft rearward, passing it under rear axle.

Watch for oil leakage from transmission rear end. Take proper action if oil leak is discovered.

**Note:** Remove propeller shaft carefully so as not to damage the spline, sleeve yoke or rear oil seal.

### INSTALLATION

To install, reverse the foregoing removal procedure.

#### **CAUTION:**

**Align propeller shaft with companion flange using reference marks prescribed in "Removal" procedure and tighten them with bolts. Failure to do so could result in driving vibration.**

ⓐ : Propeller shaft to companion flange bolts

**34 - 44 N·m  
 (3.5 - 4.5 kg·m,  
 25 - 33 ft·lb)**

### CHECKING AND CORRECTING UNBALANCED PROPELLER SHAFT

To check and correct an unbalanced propeller shaft, proceed as follows:

1. Remove undercoating and other foreign material which could upset shaft balance, and check shaft vibration by road test.

2. If shaft vibration is noted during road test, disconnect propeller shaft at differential carrier companion flange, rotate companion flange 180 degrees and reinstall propeller shaft.

3. Again check shaft vibration. If vibration still persists, replace propeller shaft assembly.

## DIFFERENTIAL CARRIER (Type R180)

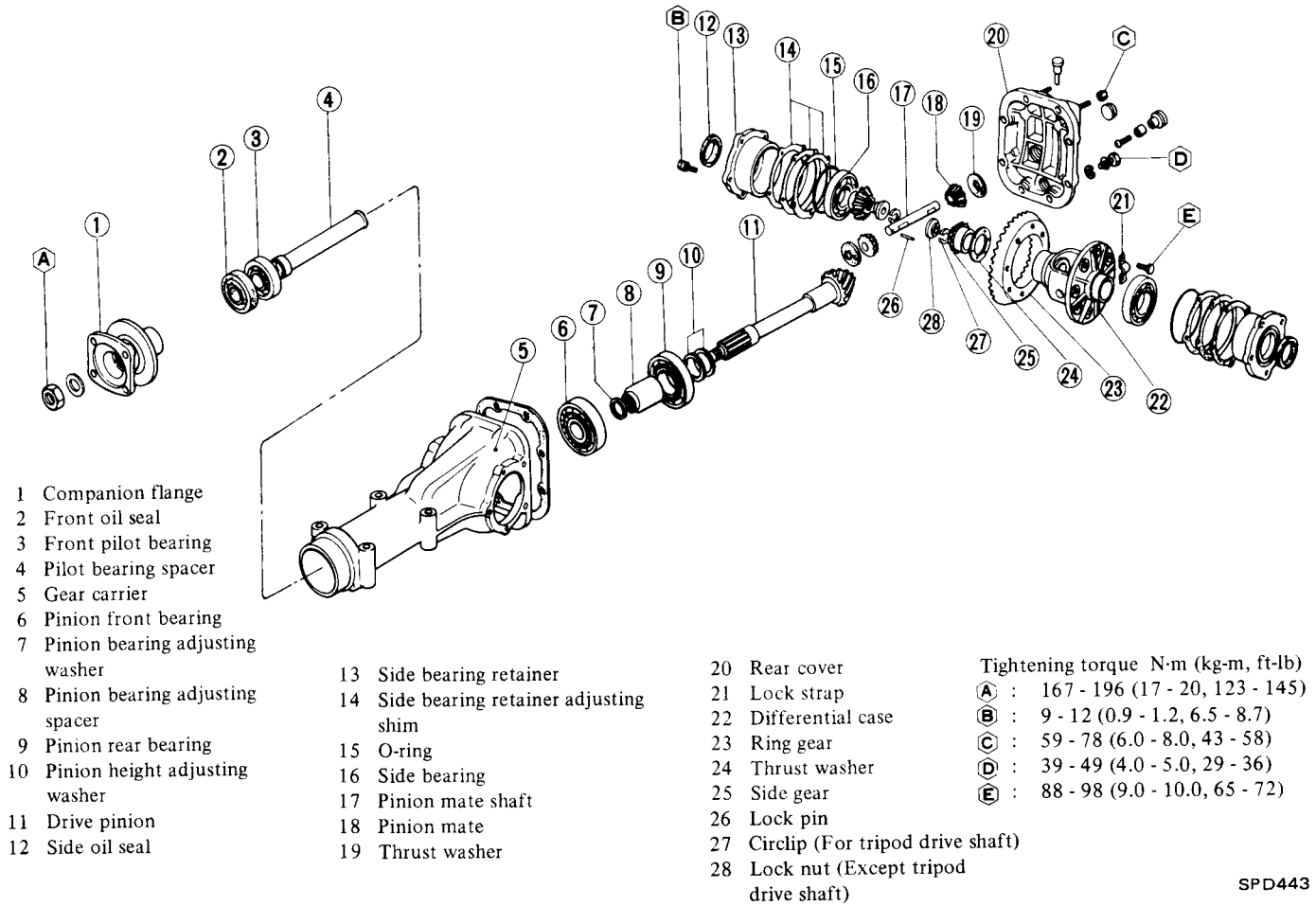

SPD443

Fig. PD-2 Differential Carrier (R180)

### REMOVAL

1. Jack up rear of car and support on safety stands. Drain gear oil.
2. Disconnect propeller shaft at companion flange.
3. Disconnect drive shafts ② on the wheel side. See Fig. PD-3.
4. Remove side yoke fixing bolts, and extract side yokes together with drive shafts (except tripod type drive shaft).
5. Draw out drive shaft (tripod type drive shaft). Refer to section RA.

#### CAUTION:

Be careful not to damage side yoke and oil seal when removing.

6. Remove plate ③. See Fig. PD-3.
7. With differential carrier jacked up, remove nuts ①.

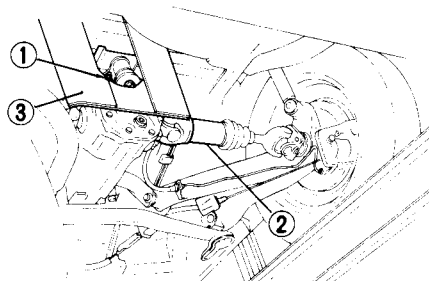

PD470

Fig. PD-3 Under View

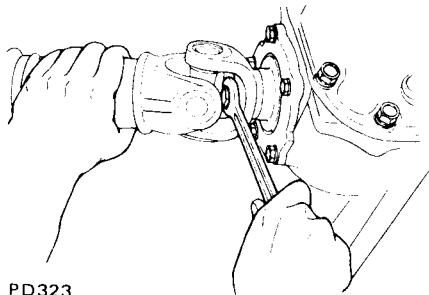

PD323

Fig. PD-4 Removing Side Yoke Fixing Bolt

8. Loosen off fitting bolts that hold differential carrier onto suspension member.
9. Pull off carrier backward together with jack.

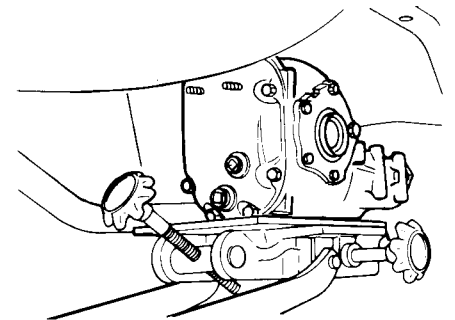

PD469

Fig. PD-5 Removing Differential Carrier

After differential carrier is removed, support suspension member on a stand to prevent its insulators being twisted or damaged.

**Note:** Do not place the center of suspension member on the stand before removal operation. Otherwise, it will be difficult to extract the differential carrier.

## PRE-DISASSEMBLY INSPECTION

Differential carrier should be inspected before any parts are removed from it.

These inspections are helpful in finding the cause of the malfunction and in determining the corrections needed.

1. Mount differential carrier on Diff. Attachment KV38100800. Remove differential mounting member and rear cover.

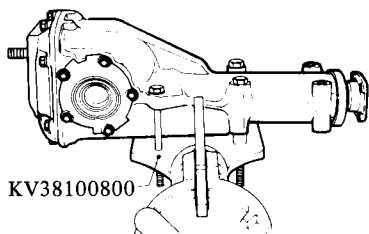

PD471

Fig. PD-6 Holding Differential Carrier

2. Visually inspect parts for wear or damage.
3. Rotate gears to see that there is any roughness which would indicate damaged bearings or chipped gears. Check gear teeth for scoring or signs of abnormal wear. Measure preload of drive pinion.
4. Set up a dial indicator and check backlash at several points around ring gear. Backlash should be specified value.

**Ring gear-to-drive pinion backlash:**  
0.10 - 0.20 mm  
(0.0039 - 0.0079 in)

5. Check the gear tooth contact with a mixture of recommended powder and oil applied sparingly to all ring gear teeth.

For the tooth contact pattern, see paragraph dealing with tooth contact pattern adjustment.

## DISASSEMBLY

1. Remove side retainers, using Diff. Side Retainer Attachment ST33710000 and suitable puller.

**Note:**

- a. Mark right and left side retainers before removal.
- b. Be careful not to confuse right and left hand side retainers and shims for proper reassembly.

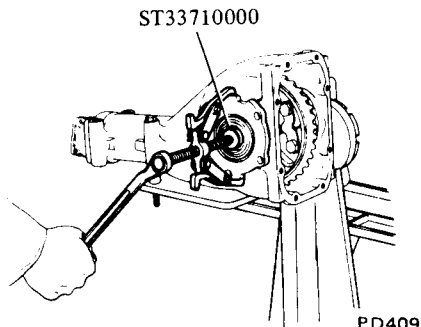

PD409

Fig. PD-7 Removing Side Retainer

2. Extract differential case assembly from gear carrier.
3. When replacing side bearing, extract bearing outer race from side retainer using Side Bearing Outer Race Puller ST33290001.

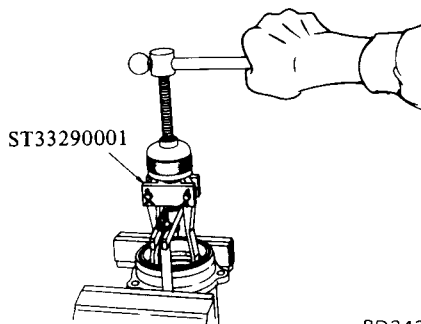

PD243

Fig. PD-8 Removing Side Bearing Outer Race

4. Remove drive pinion nut, holding companion flange with Drive Pinion Flange Wrench ST31530000 and pull off companion flange using a suitable puller.

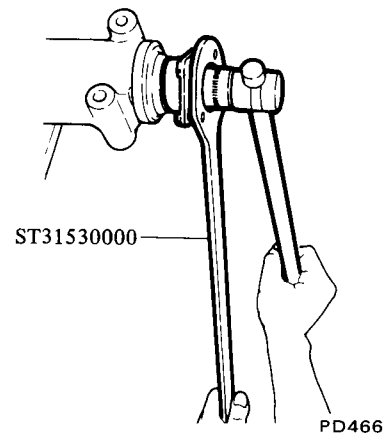

PD466

Fig. PD-9 Removing Drive Pinion Nut

5. Extract drive pinion from gear carrier using a press machine. Take out drive pinion together with rear bearing inner race, bearing spacer and adjusting washers.
6. Remove front oil seal from gear carrier.

**Note:** Oil seal must not be reused.

7. Remove pilot bearing together with pilot bearing spacer and front bearing cone using Pilot Bearing Drift ST30650001.
8. Hold rear bearing inner race with Drive Pinion Rear Bearing Inner Race Puller ST30031000 and extract from drive pinion with a press.

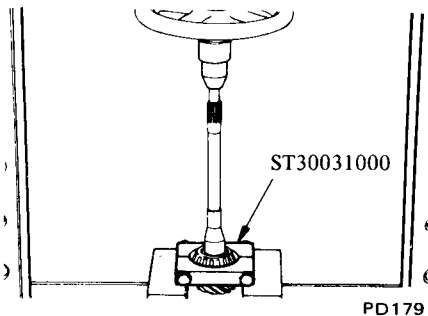

PD179

Fig. PD-10 Removing Pinion Rear Bearing Inner Race

9. To remove front and rear bearing outer races, put a drift to race surface, and withdraw them by tapping top of drift with a hammer.

## DIFFERENTIAL CASE

1. Extract bearing inner race from differential case assembly using Differential Side Bearing Puller Set ST3306S001.

Body: ST33051001  
Adapter: ST33061000

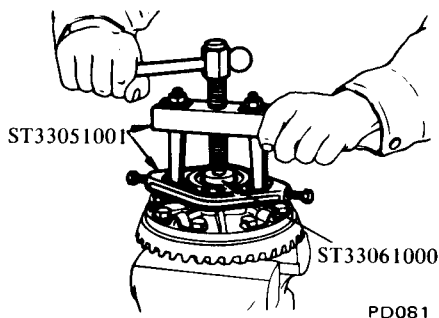

Fig. PD-11 Removing Side Bearing

**Note:**

- a. The puller should be handled with care in catching the edge of bearing inner race.
- b. Be careful not to confuse the right and left hand parts.

2. Remove ring gear by spreading out lock strap and loosening ring gear bolts diagonally.
3. Punch off pinion mate shaft lock pin from ring gear side using Solid Punch KV31100300.

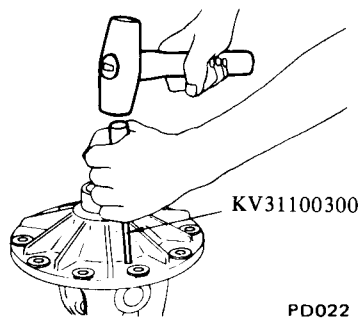

Fig. PD-12 Removing Lock Pin

4. Draw out pinion mate shaft and remove pinion mate gears, side gears and thrust washers.

**Note: Put marks on gear and thrust washer so that they can be reinstalled in their original positions from which they were removed.**

## INSPECTION

Thoroughly clean all disassembled parts, and examine them to see that they are worn, damaged or otherwise faulty, and how they are affected. Repair or replace all faulty parts, whichever is necessary.

1. Check gear teeth for scoring, cracking or chipping, and make sure that tooth contact pattern indicates correct meshing depth. If any fault is evident, replace parts as required.

**Note: Drive pinion and ring gear are supplied for replacement as a set, therefore, should either part be damaged, replace as a set.**

2. Check pinion gear shaft, and pinion gear for scores and signs of wear, and replace as required.

Follow the same procedure for side gear and their seats on differential case.

3. Inspect all bearing races and rollers for scoring, chipping or evidence of excessive wear. They should be in tiptop condition such as not worn and with mirror-like surfaces. Replace if there is a shadow of doubt on their efficiency, as incorrect bearing operation may result in noises and gear seizure.

4. Inspect thrust washer faces. Small damage can be corrected with sand paper. If pinion mate to side gear backlash (or the clearance between side gear and thrust washer) exceeds the specified value, replace thrust washers.

**Pinion mate-to-side gear backlash:**

**For tripod drive shaft**  
Less than 0.15 mm  
(0.0059 in)

**Except tripod drive shaft**  
0.10 - 0.20 mm  
(0.0039 - 0.0079 in)

5. Inspect gear carrier and differential case for cracks or distortion. If either condition is evident, replace faulty parts.

6. As a general rule, oil seal should be replaced at each disassembly.

## ASSEMBLY AND ADJUSTMENT

Assembly can be done in the reverse order of disassembly. The following directions for adjustment and usage of special tools enable to obtain a perfect differential operation.

## PRECAUTIONS IN REASSEMBLY

1. Arrange shims, washers and the like to install them correctly.
2. Thoroughly clean the surfaces on which shims, washers, bearings and bearing retainers are installed.
3. Apply gear oil when installing bearings.
4. Pack recommended multi-purpose grease into cavity between lips when fitting oil seal.

## ASSEMBLY OF DIFFERENTIAL GEAR CASE

1. Assemble pinion mates, side gears and thrust washers in differential case.
2. Fit pinion shaft to differential case so that it meets lock pin holes.
3. Adjust pinion mate-to-side gear backlash (or the clearance between the rear face of side gear and thrust washer) to the specified value by selecting side gear thrust washer.

**Pinion mate-to-side gear backlash:**

**For tripod drive shaft**  
Less than 0.15 mm  
(0.0059 in)

**Except tripod drive shaft**  
0.10 - 0.20 mm  
(0.0039 - 0.0079 in)

**Side gear thrust washer**

Thickness mm (in)
0.75 - 0.80 (0.0295 - 0.0315)
0.80 - 0.85 (0.0315 - 0.0335)
0.85 - 0.90 (0.0335 - 0.0354)

4. Lock pinion shaft lock pin using a punch after it is secured into place.
5. Apply oil to gear tooth surfaces and thrust surfaces and check if they turn properly.

6. Place ring gear on differential case and install bolts and lock straps.

Torque bolts to specifications, and bend up lock straps.

**CAUTION:**

- a. Use only genuine ring gear bolts and new lock straps.
- b. Tighten bolts in criss-cross fashion lightly tapping around bolt head with a hammer.

⊕ : Ring gear bolts  
 88 - 98 N-m  
 (9.0 - 10.0 kg-m,  
 65 - 72 ft-lb)

7. When replacing side bearing, measure bearing width using Master Gauge KV38101900 and Weight Block ST32501000 prior to installation.

**Standard bearing width:**  
 20.0 mm (0.787 in)

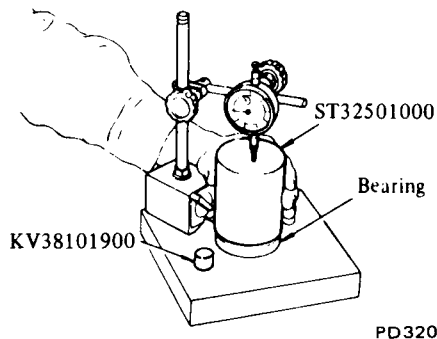

PD320

Fig. PD-13 Measuring Bearing Width

8. Press fit side bearing inner race on differential case using Diff. Side Bearing Drift ST33230000 and Adapter ST33061000.

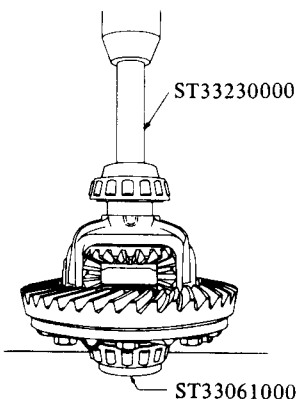

PD244

ST33061000

Fig. PD-14 Installing Side Bearing Inner Race

## ADJUSTMENT OF DRIVE PINION PRELOAD

Adjust preload of drive pinion with spacer and washer between front and rear bearing inner races, regardless of thickness of pinion height adjusting washer.

This adjustment must be carried out without oil seal inserted.

1. Press fit front and rear bearing outer races into gear carrier using

Drive Pinion Outer Race Drift Set ST30611000, ST30701000 and ST30621000.

Front: ST30611000 and ST30701000

Rear: ST30611000 and ST30621000

2. Insert Dummy Shaft Spacer ST31851000, pinion height adjusting washer and rear bearing inner race into Dummy Shaft ST31212000. See Fig. PD-17.

**Note:** Pinion height adjusting washer is inserted to facilitate adjustment of drive pinion height described below. Reuse removed washer if normal contact pattern is obtained with it.

**Standard pinion height adjusting washer thickness:**  
 3.09 - 3.66 mm  
 (0.1217 - 0.1441 in)

3. Fit drive pinion bearing spacer, washer, front bearing cone, Drive Pinion Dummy Collar ST31214000 and companion flange in this order on dummy shaft and tighten drive pinion nut to the specified torque using Stopper ST31852000.

⊕ : Drive pinion nut  
 167 - 196 N-m  
 (17 - 20 kg-m,  
 123 - 145 ft-lb)

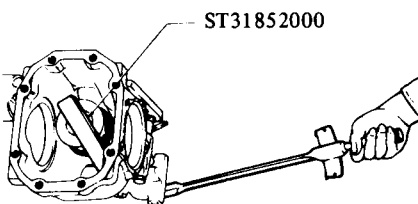

PD184

Fig. PD-15 Tightening Drive Pinion Nut

4. Measure pinion bearing preload using Preload Gauge ST3127S000, and select washer and spacer that will provide required preload.

**Note:** Replace bearing washer and spacer with thicker ones if pinion cannot be turned by hand while it is being tightened.

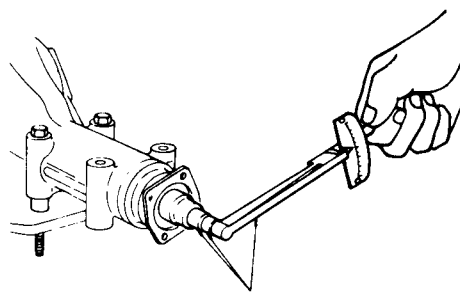

ST3127S000

PD245

Fig. PD-16 Measuring Pinion Preload

**Pinion bearing preload**

(without oil seal):

1.0 - 1.3 (10 - 13 kg-cm,  
 8.7 - 11.3 in-lb)

**Pinion bearing adjusting spacer**

Length mm (in)	
52.20	(2.0551)
52.40	(2.0630)
52.60	(2.0709)
52.80	(2.0787)
53.00	(2.0866)
53.20	(2.0945)

**Pinion bearing adjusting washer**

Thickness mm (in)	
2.30 - 2.32	(0.0906 - 0.0913)
2.32 - 2.34	(0.0913 - 0.0921)
2.34 - 2.36	(0.0921 - 0.0929)
2.36 - 2.38	(0.0929 - 0.0937)
2.38 - 2.40	(0.0937 - 0.0945)
2.40 - 2.42	(0.0945 - 0.0953)
2.42 - 2.44	(0.0953 - 0.0961)
2.44 - 2.46	(0.0961 - 0.0969)
2.46 - 2.48	(0.0969 - 0.0976)
2.48 - 2.50	(0.0976 - 0.0984)
2.50 - 2.52	(0.0984 - 0.0992)
2.52 - 2.54	(0.0992 - 0.1000)
2.54 - 2.56	(0.1000 - 0.1008)
2.56 - 2.58	(0.1008 - 0.1016)
2.58 - 2.60	(0.1016 - 0.1024)

## ADJUSTMENT OF DRIVE PINION HEIGHT

Adjust pinion height with washer

provided between rear bearing inner race and back of pinion gear.

1. Install Height Gauge ST31211000 on carrier with dummy shaft mounted.

$$\begin{aligned}
 T &= W + N - [(H - D' - S) \times 0.01] - 0.20 \\
 &= 3.09 + 0.28 - [((-2) - (+1) - (-1)) \times 0.01] - 0.20 \\
 &= 3.09 + 0.28 - [(-2 - 1 + 1) \times 0.01] - 0.20 \\
 &= 3.09 + 0.28 - [-2 \times 0.01] - 0.20 \\
 &= 3.09 + 0.28 + 0.02 - 0.20 \\
 &= 3.19 \text{ mm}
 \end{aligned}$$

The correct washer is 3.18 mm thick.

Ex. 3 ---

$$\begin{aligned}
 W &= 3.09 \text{ mm} \\
 N &= 0.45 \text{ mm} \\
 H &= 0, \quad D' = 0, \quad S = 0
 \end{aligned}$$

$$\begin{aligned}
 T &= W + N - [(H - D' - S) \times 0.01] - 0.20 \\
 &= 3.09 + 0.45 - [(0 - 0 - 0) \times 0.01] - 0.20 \\
 &= 3.09 + 0.45 - [0 \times 0.01] - 0.20 \\
 &= 3.09 + 0.45 - 0 - 0.20 \\
 &= 3.34 \text{ mm}
 \end{aligned}$$

The correct washer is 3.33 mm thick.

Pinion height adjusting washer

Thickness	mm (in)
3.09	(0.1217)
3.12	(0.1228)
3.15	(0.1240)
3.18	(0.1252)
3.21	(0.1264)
3.24	(0.1276)
3.27	(0.1287)
3.30	(0.1299)
3.33	(0.1311)
3.36	(0.1323)
3.39	(0.1335)
3.42	(0.1346)
3.45	(0.1358)
3.48	(0.1370)
3.51	(0.1382)
3.54	(0.1394)
3.57	(0.1406)
3.60	(0.1417)
3.63	(0.1429)
3.66	(0.1441)

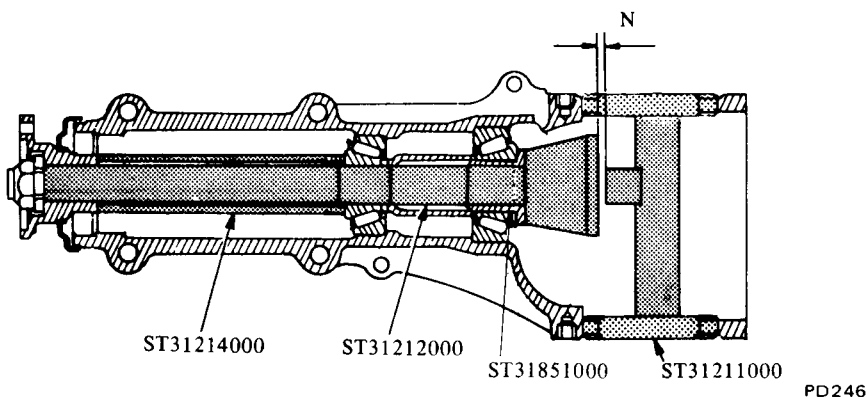

Fig. PD-17 Measuring Clearance

2. Measure the clearance (N) between the tip end of height gauge and the end surface of dummy shaft, using a thickness gauge.

Figures for H, D' and S are dimensional variations in a unit of 1/100 mm against each standard measurement.

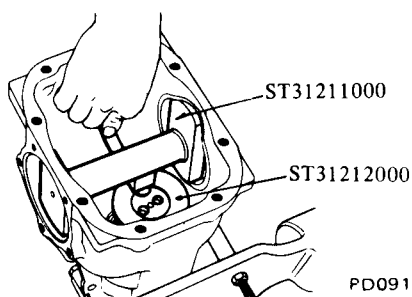

Fig. PD-18 Adjusting Pinion Height

3. The thickness of drive pinion height adjusting washer can be obtained from the following formula:

$$T = W + N - [(H - D' - S) \times 0.01] - 0.20$$

Where,

T : Required thickness of rear bearing adjusting washers (mm).

W : Thickness of washers temporarily inserted (mm).

N : Measured value with thickness gauge (mm).

H : Figure marked on the drive pinion head. See Fig. PD-19.

D' : Figure marked on the dummy shaft.

S : Figure marked on the height gauge.

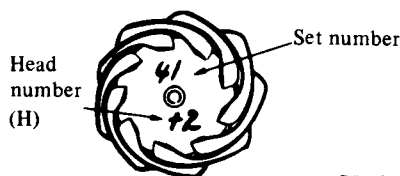

PD186

Fig. PD-19 Variation Number on Drive pinion

Examples of calculation

Ex. 1 ---

$$\begin{aligned}
 W &= 3.09 \text{ mm} \\
 N &= 0.33 \text{ mm} \\
 H &= +2, \quad D' = -1, \quad S = 0
 \end{aligned}$$

$$\begin{aligned}
 T &= W + N - [(H - D' - S) \times 0.01] - 0.20 \\
 &= 3.09 + 0.33 - [((+2) - (-1) - (0)) \times 0.01] - 0.20 \\
 &= 3.09 + 0.33 - [(2 + 1 - 0) \times 0.01] - 0.20 \\
 &= 3.09 + 0.33 - [3 \times 0.01] - 0.20 \\
 &= 3.09 + 0.33 - 0.03 - 0.20 \\
 &= 3.19 \text{ mm}
 \end{aligned}$$

The correct washer is 3.18 mm thick.

Ex. 2 ---

$$\begin{aligned}
 W &= 3.09 \text{ mm} \\
 N &= 0.28 \text{ mm} \\
 H &= -2, \quad D' = +1, \quad S = -1
 \end{aligned}$$

Note: If values signifying H, D' and S are not given, regard them as zero and compute. After assembly, check to see that tooth contact is correct. If not, readjust.

4. Fit determined pinion height adjusting washer in drive pinion, and press fit rear bearing inner race in it using Base ST30901000.

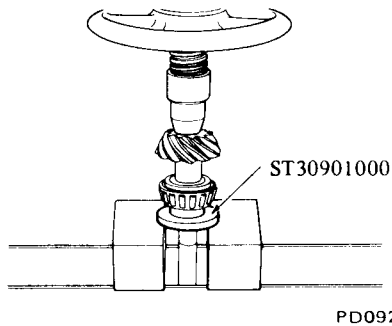

PD092

Fig. PD-20 Pressing Rear Bearing Inner Race

5. Lubricate pinion front and rear bearings. Install drive pinion in gear carrier into which drive pinion bearing spacer and washer, front bearing inner race and front bearing pilot spacer, moreover, pilot bearing and oil seal are fitted. Fit oil seal using Oil Seal Drift ST30720000.

6. Fit companion flange on drive pinion, and secure it in position by tightening nut to specified torque confirming preload.

Note: If drive pinion lock nut is worn, replace it.

⊕ : Drive pinion nut  
 167 - 196 N·m  
 (17 - 20 kg·m,  
 123 - 145 ft·lb)

Drive pinion preload  
 (with oil seal):  
 0.9 - 1.7 N·m  
 (9 - 17 kg·cm,  
 7.8 - 14.8 in·lb)

## ADJUSTMENT OF SIDE RETAINER SHIMS

1. If the hypoid gear set, gear carrier, differential case, side bearing or side bearing retainer has been replaced with new part, adjust the side bearing

preload with adjusting shim. The required thickness of the right and left retainer shims can be obtained from the following formulas:

$$T_1 = (A + C + G_1 - D) \times 0.01 + 0.76 - E$$

$$T_2 = (B + D + G_2) \times 0.01 + 0.76 - F$$

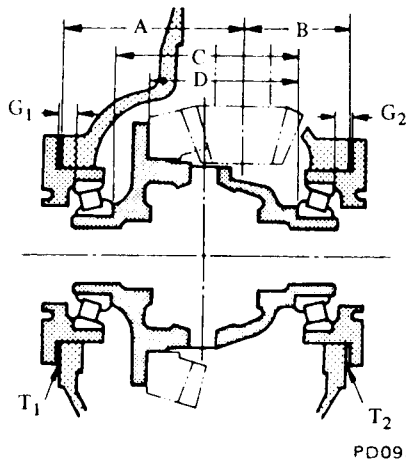

PD093

Fig. PD-21 Thickness of Right and Left Shims

Where,

T<sub>1</sub> : Required thickness of left side retainer shim (mm).

T<sub>2</sub> : Required thickness of right side retainer shim (mm).

A & B : Figures marked on the gear carrier.

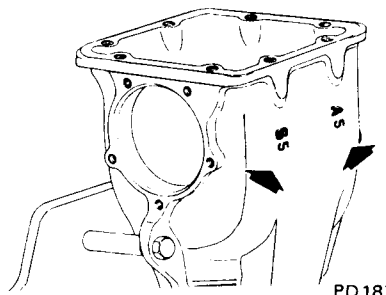

PD187

Fig. PD-22 A & B Figures

C & D : Figures marked on the differential case.

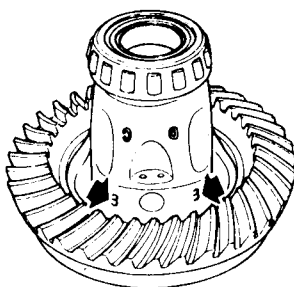

PD188

Fig. PD-23 C & D Figures

E & F : These are differences in width of left or right side bearing against the standard width 20.00 mm (0.7874 in).

If bearing width is 19.90, the difference will be as follows:

$$20.00 - 19.90 = 0.10$$

G<sub>1</sub> & G<sub>2</sub> : Figures marked on the left or right side retainer.

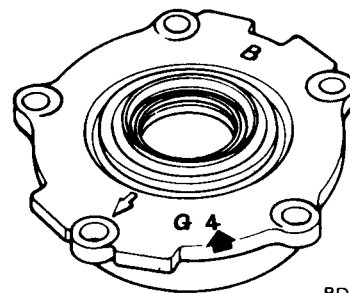

PD189

Fig. PD-24 G<sub>1</sub> & G<sub>2</sub> Figure

Figures for A, B, C, D, G<sub>1</sub> and G<sub>2</sub> are dimensional variations in a unit of 1/100 mm against each standard measurement.

Examples of calculation

Ex. 1 ---

$$A = 5, B = 5, C = 3, D = 3, \\ G_1 = 4, G_2 = 1, E = 0.10 \text{ mm}, \\ F = 0.15 \text{ mm}$$

Left side:

$$T_1 = (A + C + G_1 - D) \times 0.01 + 0.76 - E \\ = (5 + 3 + 4 - 3) \times 0.01 + 0.76 - 0.10 \\ = 9 \times 0.01 + 0.76 - 0.10 \\ = 0.09 + 0.76 - 0.10 \\ = 0.75 \text{ mm}$$

The correct shims are as follows:

Thickness	Quantity	
0.25	x 1	= 0.25
0.50	x 1	= 0.50
Total thickness		= 0.75 mm



Right side:

$$T_2 = (B + D + G_2) \times 0.01 + 0.76 - F$$

$$= (5 + 3 + 1) \times 0.01 + 0.76 - 0.15$$

$$= 9 \times 0.01 + 0.76 - 0.15$$

$$= 0.09 + 0.76 - 0.15$$

$$= 0.70 \text{ mm}$$

The correct shims are 0.20 plus 0.50 mm thick.

Ex. 2 --

A = 2, B = 3, C = 0, D = 3  
 G<sub>1</sub> = 2, G<sub>2</sub> = 3, E = 0.20 mm,  
 F = 0.20 mm

Left side:

$$T_1 = (A + C + G_1 - D) \times 0.01 + 0.76 - E$$

$$= (2 + 0 + 2 - 3) \times 0.01 + 0.76 - 0.20$$

$$= 1 \times 0.01 + 0.76 - 0.20$$

$$= 0.01 + 0.76 - 0.20$$

$$= 0.57 \text{ mm}$$

The correct shims are 0.25 plus 0.30 mm thick.

Right side:

$$T_2 = (B + D + G_2) \times 0.01 + 0.76 - F$$

$$= (3 + 3 + 3) \times 0.01 + 0.76 - 0.20$$

$$= 9 \times 0.01 + 0.76 - 0.20$$

$$= 0.09 + 0.76 - 0.20$$

$$= 0.65 \text{ mm}$$

The correct shims are as follows:

Thickness	Quantity	
0.25	x 1	= 0.25
0.40	x 1	= 0.40
<b>Total thickness</b>		<b>= 0.65 mm</b>

Note: If values signifying A, B, C, D, G<sub>1</sub> and G<sub>2</sub> are not given, regard them as zero and compute.

After assembly, check to see that preload and backlash are correct. If not, readjust.

Side retainer adjusting shim

Thickness mm (in)
0.20 (0.0079)
0.25 (0.0098)
0.30 (0.0118)
0.40 (0.0157)
0.50 (0.0197)

2. Press fit side bearing outer race into side retainer using a set of Drive Pinion Bearing Outer Race Drift Bar ST30611000 and Drift ST30621000.

3. Fit given shims and O-ring in both side retainers, and install retainers in gear carrier using Diff. Side Retainer Guide ST33720000, and the arrow mark on retainer positioned as shown in Fig. PD-26.

Note: When installing retainers, take care that side bearing outer races are not damaged by roller.

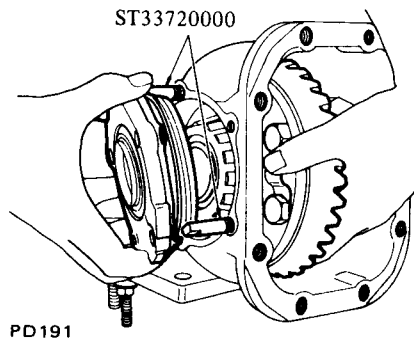

PD191

Fig. PD-25 Installing Side Retainer

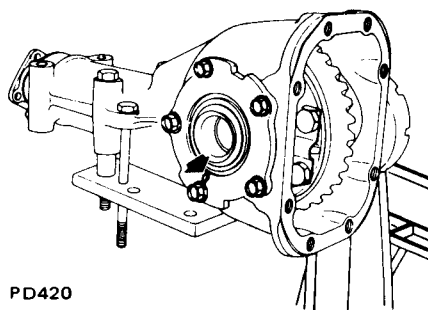

PD420

Fig. PD-26 Arrow Mark on Retainer

4. Measure ring gear-to-drive pinion backlash. If backlash is too small, decrease thickness of left shim and

increase thickness of right shim by the same amount. If backlash is too great, reverse the above procedure.

**Ring gear-to-drive pinion backlash**  
**0.10 - 0.20 mm**  
**(0.0039 - 0.0079 in)**

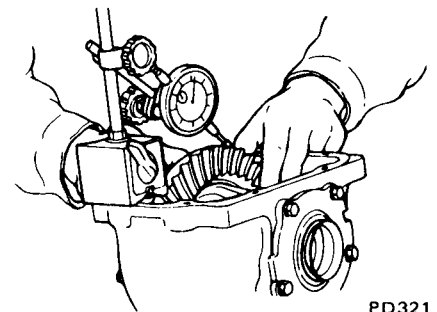

PD321

Fig. PD-27 Measuring Backlash of Ring Gear and Pinion

5. At the same time, check side bearing preload. Bearing preload should be the specified torque.

If preload is not according to this specification, adjust it with side retainer shims.

**Side bearing preload:**

**1.2 - 2.0 N·m**  
**(12 - 20 kg·cm,**  
**10.4 - 17.4 in·lb)**

**At ring gear bolt:**

**17.7 - 29.4 N**  
**(1.8 - 3.0 kg,**  
**4.0 - 6.6 lb)**

6. Check and adjust the tooth contact pattern of ring gear and drive pinion.

(1) Thoroughly clean ring and drive pinion gear teeth.

(2) Paint ring gear teeth lightly and evenly with a mixture of powdered ferric oxide and oil of a suitable consistency to produce a contact pattern.

(3) Rotate pinion through several revolutions in the forward and reverse direction until a definite contact pattern is developed on ring gear.

(4) When contact pattern is incorrect, readjust thickness of adjusting shim. Be sure to wipe off ferric oxide completely upon completion of adjustment.

(5) Incorrect contact pattern of teeth can be adjusted in the following manner.

## Contact pattern

### a. Heel contact

To correct, increase thickness of pinion height adjusting washer in order to bring drive pinion close to ring gear.

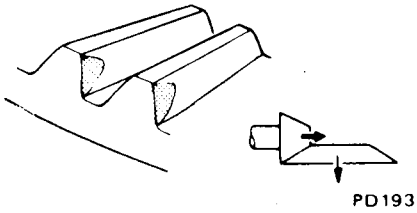

Fig. PD-28 Heel Contact

### b. Toe contact

To correct, reduce thickness of pinion height adjusting washer in order to make drive pinion go away from ring gear.

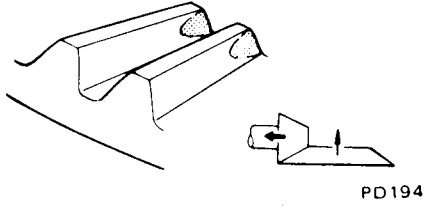

Fig. PD-29 Toe-Contact

### c. Flank contact

Adjust in the same manner as in b.

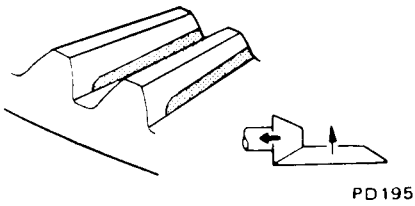

Fig. PD-30 Flank Contact

### d. Face contact

Adjust in the same manner as in a.

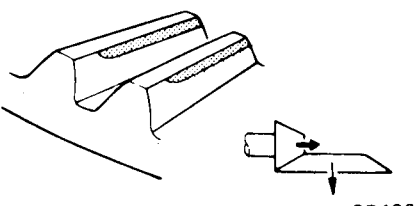

Fig. PD-31 Face Contact

### e. Correct tooth contact

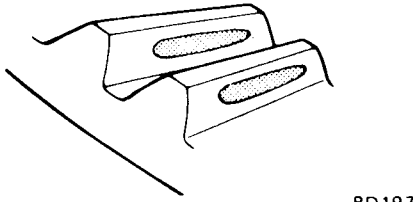

Fig. PD-32 Correct Contact

Note: Change in thickness of adjusting washer is accompanied by change in backlash. Check it when installing gear.

### 7. Install rear cover.

- ⊕ : **Rear cover attaching bolts**  
39 - 49 N-m  
(4.0 - 5.0 kg-m,  
29 - 36 ft-lb)

## INSTALLATION

Install in the reverse order of removal.

1. Position differential carrier onto suspension member, and temporarily tighten it with four bolts.
2. Fit rear cover to mounting insulator nuts ⊕ in Fig. PD-3 and tighten nuts to specified torque.

- ⊕ : **Rear cover to mounting insulator nuts**  
59 - 78 N-m  
(6.0 - 8.0 kg-m,  
43 - 58 ft-lb)

3. Secure differential carrier onto rear suspension member with bolts.

- ⊕ : **Differential carrier to suspension member bolts**  
59 - 78 N-m  
(6.0 - 8.0 kg-m,  
43 - 58 ft-lb)

4. Install side yokes together with drive shafts to differential carrier, and tighten side yoke fixing bolts to specified torque (except tripod drive shaft).

Note: Be careful not to damage side yoke and oil seal when installing.

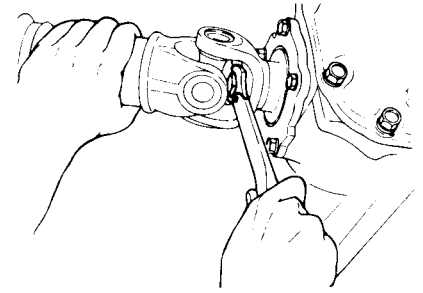

Fig. PD-33 Tightening Side Yoke Fixing Bolt

- ⊕ : **Side yoke fixing bolts**  
31 - 42 N-m  
(3.2 - 4.3 kg-m,  
23 - 31 ft-lb)

5. Install drive shaft (tripod drive shaft).

6. Join drive shafts with companion flanges of rear axle shafts and tighten connecting bolts to specified torque.

- ⊕ : **Drive shaft to axle shaft bolts**  
Except tripod drive shaft  
49 - 59 N-m  
(5.0 - 6.0 kg-m,  
36 - 43 ft-lb)

- Tripod drive shaft  
27 - 37 N-m  
(2.8 - 3.8 kg-m,  
20 - 27 ft-lb)

7. Install other parts in the reverse manner of removal.

- ⊕ : **Drain and filler plugs**  
41 - 68 N-m  
(4.2 - 6.9 kg-m,  
30 - 50 ft-lb)

- Gear oil capacity:  
1.0 liter (2-1/8 US pt,  
1-3/4 Imp pt)

## REPLACEMENT OF OIL SEAL

### FRONT OIL SEAL

To replace front oil seal with differential carrier installed on the car, proceed as follows:

1. Drain gear oil.
2. Raise car on hoist.
3. Detach propeller shaft.
4. Remove drive pinion nut.
5. Extract companion flange using a standard puller.

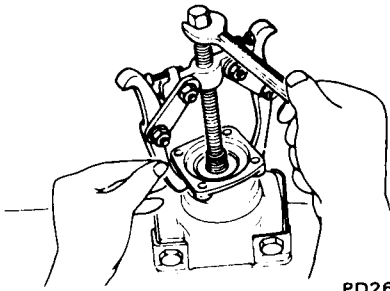

PD264  
Fig. PD-34 Removing Companion Flange

6. Remove oil seal.
7. Set new oil seal in position using Oil Seal Drift ST30720000. Apply grease cavity between seal lips.
8. Fit companion flange on drive pinion, and secure them in position by tightening nut to specified torque confirming the following preload, using Drive Pinion Flange Wrench ST31530000.

- Ⓣ : Drive pinion nut  
 167 - 196 N·m  
 (17 - 20 kg-m,  
 123 - 145 ft-lb)  
 Pinion bearing preload  
 (with oil seal):  
 0.9 - 1.7 N·m  
 (9 - 17 kg-cm,  
 7.8 - 14.8 in-lb)

Note: The preload of old bearing is the same value as that of a new bearing.

9. Reinstall propeller shaft by reversing the foregoing removal procedure. And fill up gear oil.

## SIDE OIL SEAL

Side oil seal is replaced by using the

following procedures.

- (1) Detach drive shaft from differential carrier.
- (2) Remove oil seal.
- (3) Set in new oil seal with Side Oil Seal Drift ST33270000.

Note: Apply grease cavity between oil seal lips.

- (4) Reinstall drive shaft.

Note: Check O-ring of side flange fixing bolt, and replace if necessary.

- Ⓣ : Side yoke fixing bolt  
 31 - 42 N·m  
 (3.2 - 4.3 kg-m,  
 23 - 31 ft-lb)  
 Drive shaft to axle shaft bolts  
 49 - 59 N·m  
 (5.0 - 6.0 kg-m,  
 36 - 43 ft-lb)

## DIFFERENTIAL CARRIER (Type R200)

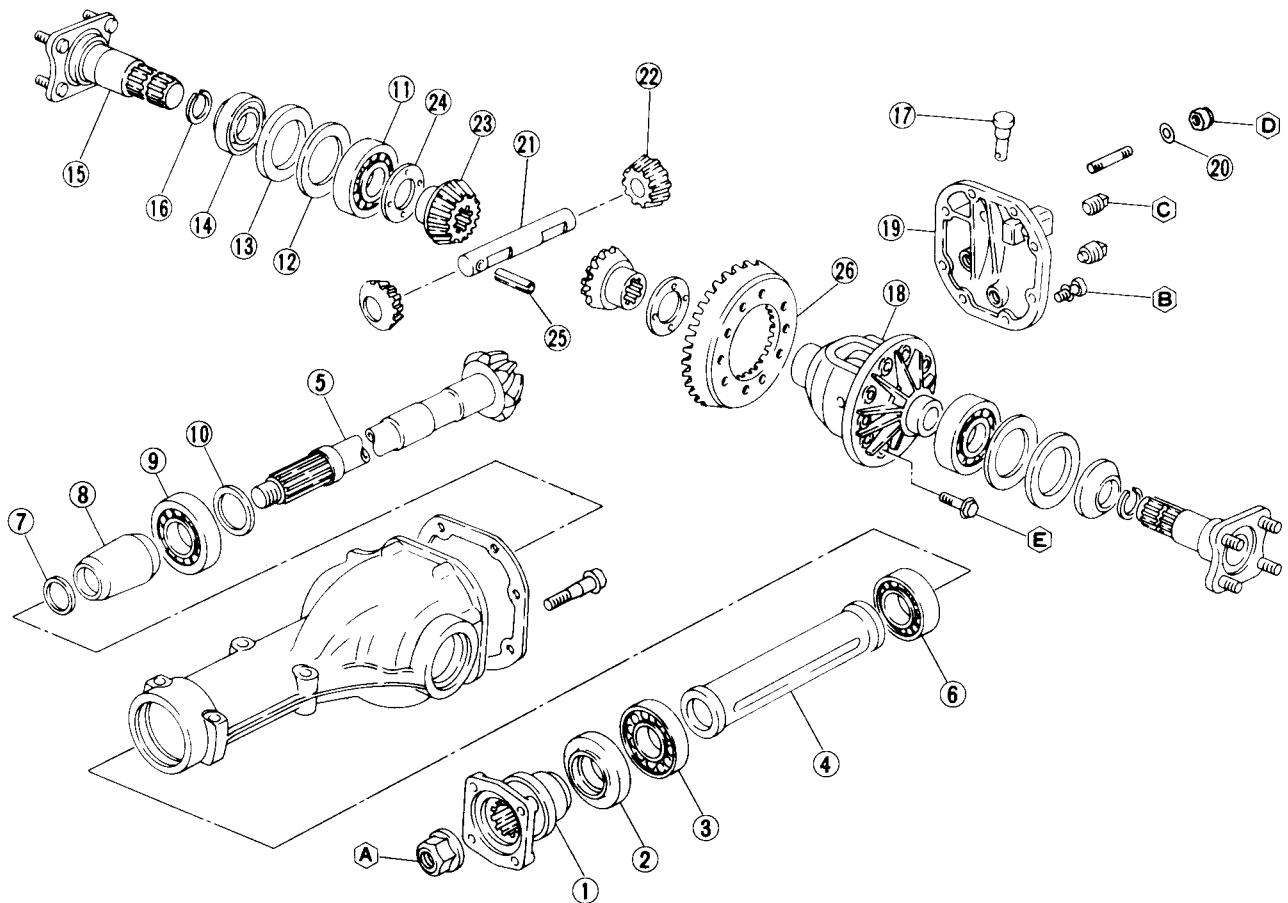

- |                                   |  |                      |
|-----------------------------------|--|----------------------|
| 1 Companion flange                | 11 Side bearing                            | 21 Pinion mate shaft |
| 2 Front oil seal                  | 12 Side bearing adjusting washer           | 22 Pinion mate       |
| 3 Front pilot bearing             | 13 Side bearing spacer                     | 23 Side gear         |
| 4 Front pilot bearing spacer      | 14 Side oil seal                           | 24 Thrust washer     |
| 5 Drive pinion                    | 15 Side flange (Except tripod drive shaft) | 25 Lock pin          |
| 6 Pinion front bearing            | 16 Side flange circlip                     | 26 Ring gear         |
| 7 Pinion bearing adjusting washer | 17 Breather                                |                      |
| 8 Pinion bearing adjusting spacer | 18 Differential case                       |                      |
| 9 Pinion rear bearing             | 19 Rear cover                              |                      |
| 10 Pinion height adjusting washer | 20 Special washer                          |                      |

Tightening torque  $\uparrow$  of bolts and nuts N-m (kg-m, ft-lb)

- A** : 186 - 216 (19 - 22, 137 - 159)
- B** : 16 - 24 (1.6 - 2.4, 12 - 17)
- C** : 39 - 59 (4 - 6, 29 - 43)
- D** : 88 - 118 (9.0 - 12.0, 65 - 87)
- E** : 59 - 69 (6.0 - 7.0, 43 - 51)

Using locking agent [Locktite (stud lock) or equivalent]

PD467

Fig. PD-35 Differential Carrier (R200)

### REMOVAL

1. Jack up rear of car and support on safety stands. Drain gear oil.
2. Disconnect propeller shaft at companion flange.
3. Disconnect drive shafts **2** on the wheel side. See Fig. PD-36.
4. Remove side flange fixing bolts, and disconnect flange yokes together with drive shafts from differential carrier (except tripod type drive shaft).

5. Draw out drive shaft (tripod type drive shaft). Refer to section RA.
6. Remove plate **3**. See Fig. PD-36.
7. With differential carrier jacked up, remove nuts **1**.

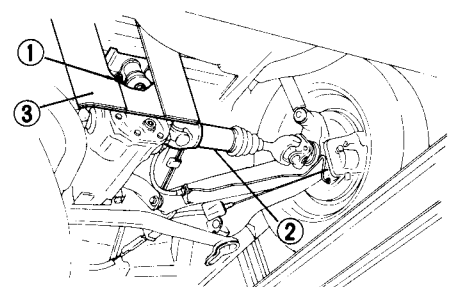

PD470

Fig. PD-36 Under View

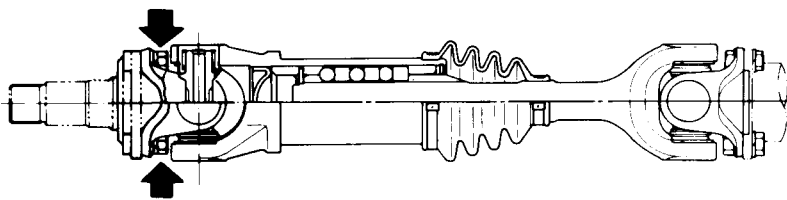

PD468

Fig. PD-37 Removing Side Flange Fixing Bolt

8. Loosen off four fitting bolts that hold differential carrier onto suspension member.
9. Pull off differential carrier backward together with jack.

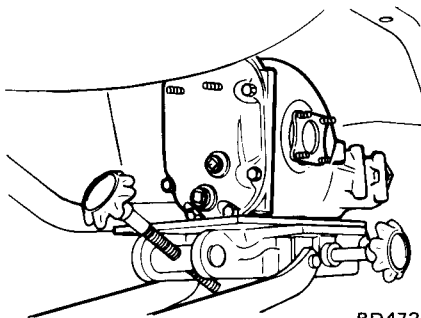

PD472

Fig. PD-38 Removing Differential Carrier

After carrier assembly is removed, support suspension member on a stand to prevent its insulators being twisted or damaged.

**Note:** Do not place the center of suspension member on the stand before removal operation. Otherwise, it will be difficult to extract the gear carrier assembly.

## PRE-DISASSEMBLY INSPECTION

Differential carrier should be inspected before parts except rear cover are removed from it.

These inspections are helpful in finding the cause of the problem and in determining necessary corrections.

1. Using three 45 mm (1.77 in) spacers, mount carrier on Diff. Attachment KV38100800.

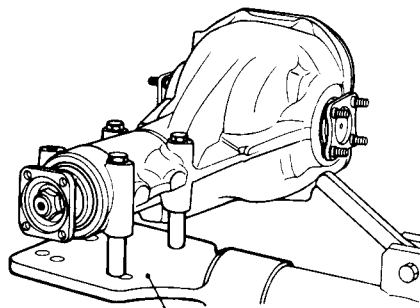

KV38100800

PD418

Fig. PD-39 Mounting Differential Carrier

2. Remove rear cover.
3. Visually inspect parts for wear or damage.
4. Rotate gears checking for any roughness which would indicate damaged bearings or chipped gears. Check gear teeth for scoring or signs of abnormal wear. Measure preload of drive pinion.

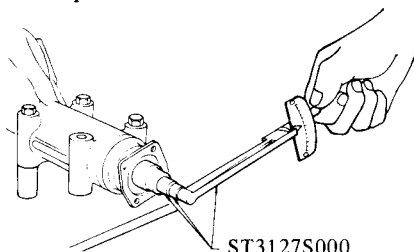

ST3127S000

PD340

Fig. PD-40 Measuring Pinion Preload

5. Set up a dial indicator and check the backlash at several points around ring gear.

**Ring gear-to-drive pinion backlash:**  
**0.13 - 0.18 mm**  
**(0.0051 - 0.0071 in)**

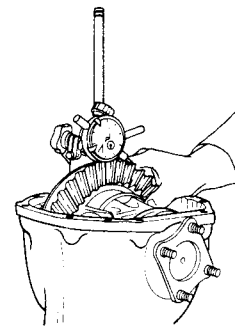

PD341

Fig. PD-41 Measuring Backlash of Ring Gear and Pinion

6. Check gear tooth contact with a mixture of recommended powder and oil.

For the tooth contact pattern, see Figs. PD-28 through PD-32. – Contact Pattern.

## DISASSEMBLY

1. Drive side flange out with pry bar.

**Note:** Hold side flange with hand to prevent it from jumping out of carrier.

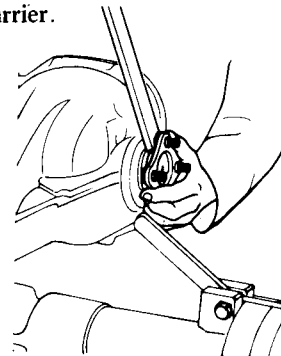

PD342

Fig. PD-42 Removing Side Flange

2. Put match marks on side bearing caps and carrier.
3. Loosen side bearing cap bolts and remove bearing caps.

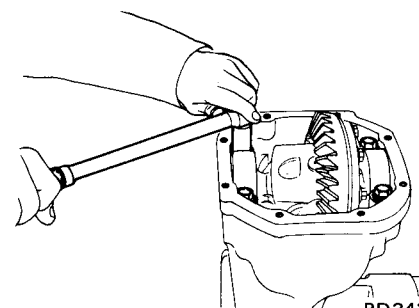

PD343

Fig. PD-43 Removing Side Bearing Cap

4. Using Slide Hammer HT72400000 lift differential case assembly out.

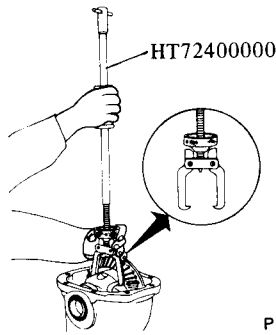

PD344

Fig. PD-44 Removing Differential Assembly Case

Note: Care should be taken not to confuse the left and right hand bearing caps and bearing outer races so that parts may be installed to the original position.

5. Loosen drive pinion nut, holding companion flange with Drive Pinion Flange Wrench ST31530000 and pull off companion flange using a suitable puller.

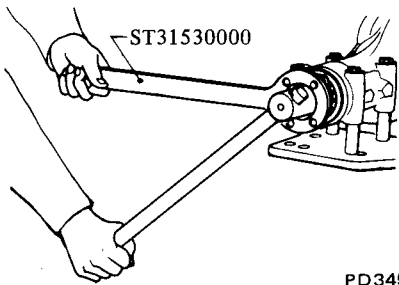

PD345

Fig. PD-45 Removing Drive Pinion Nut

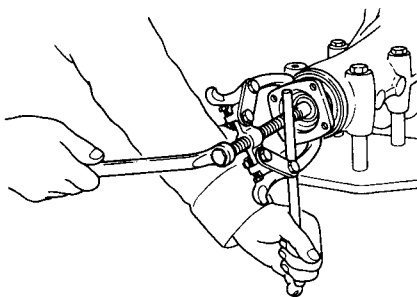

PD346

Fig. PD-46 Removing Companion Flange

6. Extract drive pinion from carrier using a press. Take out drive pinion together with rear bearing inner race, bearing spacer and adjusting washer.

7. Remove oil seal.

Note: Oil seal must not be reused.

8. Remove pilot bearing together with pilot bearing spacer and front bearing inner race using Pilot Bearing Drift KV38100401. See Fig. PD-47.

9. Remove side oil seal.

Note: Oil seal must not be reused.

10. Hold rear bearing inner race with Puller ST30031000 and extract from drive pinion with a press. See Fig. PD-48.

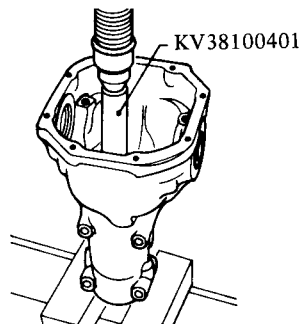
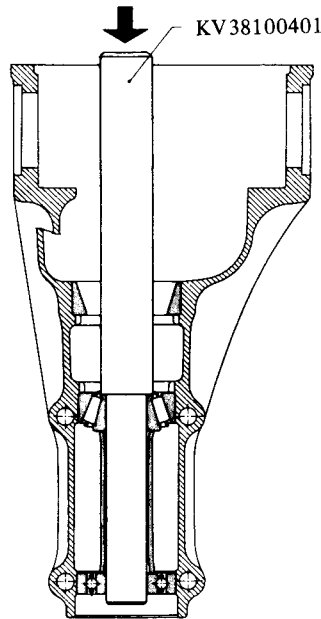

PD348

Fig. PD-47 Removing Pilot Bearing

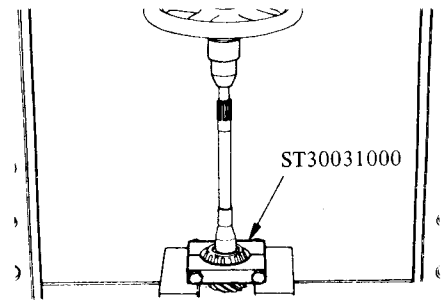

PD179

Fig. PD-48 Removing Pinion Rear Bearing Inner Race

11. To remove front and rear bearing outer races, put a drift to race surface, and withdraw them by tapping the top of drift with a hammer.

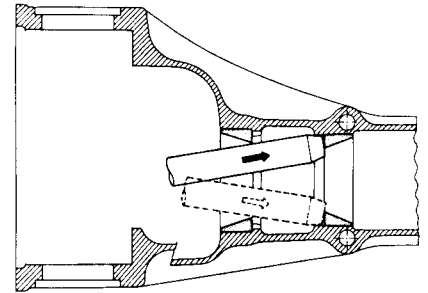

PD349

Fig. PD-49 Removing Pinion Bearing Outer Races

## DIFFERENTIAL CASE

1. Extract bearing using Differential Side Bearing Puller ST3306S001 (set of ST33051001 and ST33061000).

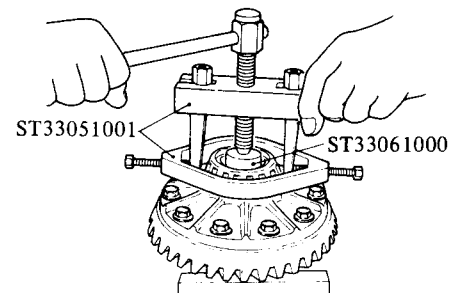

PD350

Fig. PD-50 Removing Side Bearing

Note:

- Securely attach puller to bearing inner race, utilizing two grooves in differential case.
- Be careful not to confuse the left and right hand parts.

2. Remove ring gear by loosening ring gear bolts.

**Note:** Loosen bolts diagonally.

3. Punch off pinion mate shaft lock pin from ring gear side using Sold Punch KV31100300.

**Note:** Lock pin is caulked at pin hole mouth on differential case. Do not punch it off forcibly without checking how it is caulked.

4. Draw out pinion mate shaft and remove pinion mate gears, side gears and thrust washers.

**Note:** Put marks on gear and thrust washer so that they can be re-installed in their original positions from which they were removed.

4. Inspect thrust washer faces. Small faults can be corrected with sandpaper. If pinion mate to side gear backlash (or the clearance between side gear and thrust washer) exceeds the specified value, replace thrust washers.

**Pinion mate-to-side gear backlash:**

**For tripod drive shaft**

Less than 0.15 mm  
(0.0059 in)

**Except tripod drive shaft**

0.10 - 0.20 mm  
(0.0039 - 0.0079 in)

5. Inspect carrier and differential case for cracks or distortion. If either condition is evident, replace faulty parts.

6. As a general rule, oil seal should be replaced at each disassembly.

If above procedure is not effective with existing washer, try with other washers.

**Pinion mate-to-side gear backlash:**

**For tripod drive shaft**

Less than 0.15 mm  
(0.0059 in)

**Except tripod drive shaft**

0.10 - 0.20 mm  
(0.0039 - 0.0079 in)

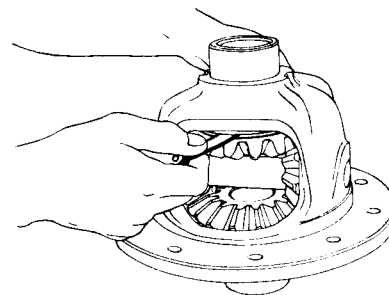

PD023

Fig. PD-51 Measuring Clearance

4. Lock pinion shaft lock pin using a punch after it is secured in place.

5. Apply oil to gear tooth surfaces and thrust surfaces and check that they turn properly.

6. Place ring gear on differential case and apply a small amount of locking agent [Loctite (stud lock) or equivalent] to the bolts; then install bolts.

## INSPECTION

Thoroughly clean all disassembled parts, and examine them to see that they are worn, damaged or otherwise faulty, and how they are affected. Repair or replace all faulty parts, whichever is necessary.

1. Check gear teeth for scoring, cracking or chipping, and make sure that tooth contact pattern indicates correct meshing depth. If any fault is evident, replace parts as required.

**Note:** Drive pinion and drive gear are supplied for replacement as a set, therefore, should either part be damaged, replace as a set.

2. Check pinion gear shaft, and pinion gear for scores and signs of wear, and replace as required.

Follow the same procedure for side gears and their seats on differential case.

3. Inspect all bearing races and rollers for scoring, chipping or evidence of excessive wear. They should be in tiptop condition such as not worn and with mirror-like surfaces. Replace if there is a shadow of doubt on their efficiency, as an incorrect bearing operation may result in noise and gear seizure.

## ASSEMBLY AND ADJUSTMENT

Assembly can be done in the reverse order of disassembly. Adherence to the following directions for adjustment and usage of special tools enable to obtain a perfect differential operation.

### PRECAUTIONS IN REASSEMBLY

1. Arrange shims, washers and the like to install them correctly.

2. Thoroughly clean the surfaces on which shims, washers, bearings and bearing retainers are installed.

3. Thoroughly clean oil from ring gear bolt and its hole with "Loctite Lacquic Primer" or equivalent.

4. Apply gear oil when installing bearings.

5. Pack recommended multi-purpose grease into cavity between lips when fitting oil seal.

### ASSEMBLY OF DIFFERENTIAL GEAR CASE

1. Assemble pinion mates, side gears and thrust washers in differential case.

2. Fit pinion shaft to differential case so that it meets lock pin holes.

3. Adjust side gear-to-pinion mate backlash or adjust the clearance between the rear face of side gear and thrust washer.

### CAUTION:

a. Use only genuine drive gear bolts and new lock straps.

b. Tighten bolts in criss-cross fashion lightly tapping around bolt heads with a hammer.

Ⓡ : Ring gear bolts  
59 - 69 N·m  
(6.0 - 7.0 kg-m,  
43 - 51 ft-lb)

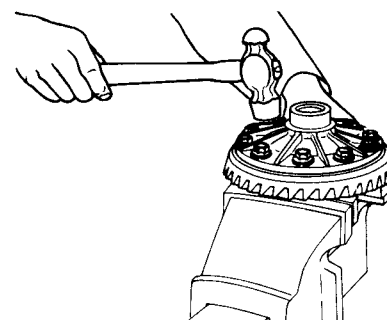

PD351

Fig. PD-52 Tapping Bolt Heads

7. When replacing side bearing, measure bearing width using Master Gauge KV38102000 and Weight Block ST32501000 prior to installation.

**Standard bearing width:  
21.0 mm (0.827 in)**

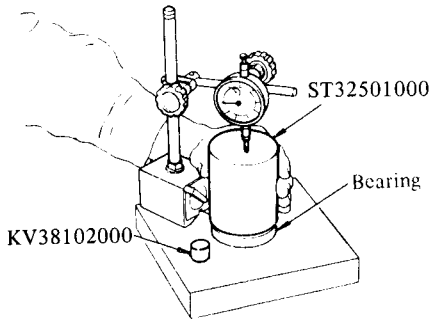

PD425

Fig. PD-53 Measuring Bearing Width

8. Press fit side bearing inner race on differential case with Diff. Side Bearing Drift KV38100300 and Adapter ST33061000.

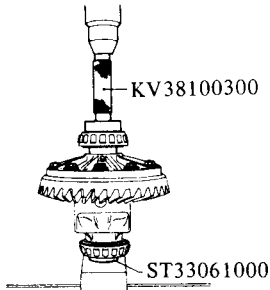

PD353

Fig. PD-54 Installing Side Bearing Inner Race

## ADJUSTMENT OF DRIVE PINION PRELOAD

Adjust drive pinion preload with spacer and washer between front and rear bearing inner races, regardless of thickness of pinion height adjusting washer.

This adjustment must be carried out without oil seal inserted.

1. Press fit front and rear bearing outer races into gear carrier using Drive Pinion Outer Race Drift Set ST30611000, ST30613000 and ST30621000.

Front: ST30611000 and ST30613000

Rear: ST30611000 and ST30621000

2. Insert rear bearing inner race into Dummy Shaft KV38100110.
3. Fit drive pinion bearing spacer, washer, front bearing inner race, Dummy Shaft Collar KV38100130 and companion flange in that order on dummy shaft and tighten drive pinion nut with Stopper KV38100140.

⊕ : Drive pinion nut  
186 - 216 N·m  
(19 - 22 kg·m,  
137 - 159 ft·lb)

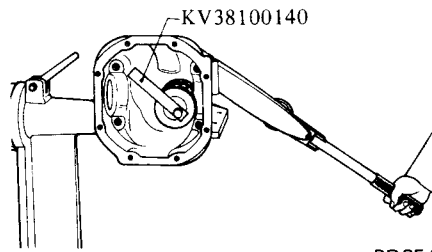

PD354

Fig. PD-55 Tightening Drive Pinion Nut

4. Measure pinion bearing preload using Preload Gauge ST3127S000, and select washer and spacer that will provide required preload.

**Pinion bearing preload  
(without oil seal):**  
1.0 - 1.3 N·m  
(10 - 13 kg·cm,  
8.7 - 11.3 in·lb)

**Note:**

- a. Replace bearing washer and spacer with thicker ones if pinion cannot be turned by hand while it is being tightened.
- b. Preload of old bearing is the same value as that of a new bearing.

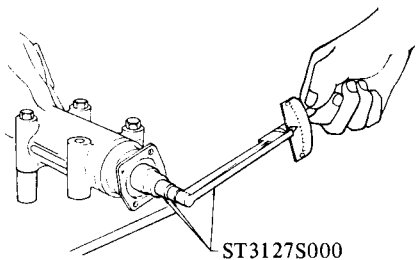

PD340

Fig. PD-56 Measuring Pinion Preload

## ADJUSTMENT OF DRIVE PINION HEIGHT

Adjust pinion height with washer located between rear bearing inner race and back of pinion gear.

1. Install Height Gauge KV38100120 on carrier with dummy shaft mounted.

Height gauge (KV38100120)

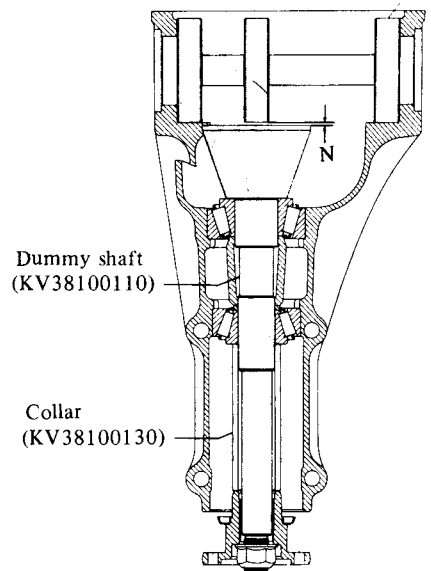

PD355

Fig. PD-57 Measuring Clearance (N)

2. Measure the clearance (N) between the tip end of height gauge and the end surface of dummy shaft, using a thickness gauge.

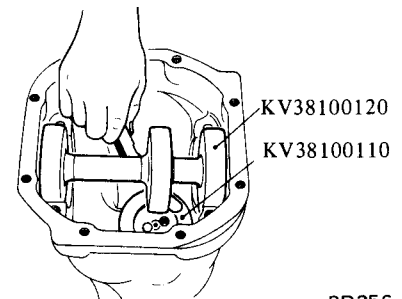

PD356

Fig. PD-58 Adjusting Pinion Height

3. The thickness of drive pinion height adjusting washer can be obtained from the following formula:

$$T = N - [(H - D') \times 0.01] + 3.00$$



Where,

T : Required thickness of rear bearing adjusting washers (mm).

N : Measured value with thickness gauge (mm).

H : Figure marked on the drive pinion head. See Fig. PD-59.

D' : Figure marked on the dummy shaft.

**Note:** Figures for H and D' are dimensional variations in a unit of 1/100 mm (4/10,000 in) against each standard measurement.

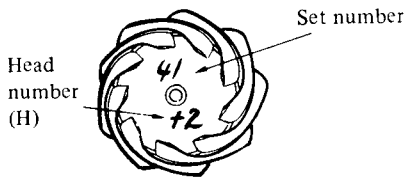

PD186

Fig. PD-59 Variation Number on Drive Pinion

Examples of calculation

Ex. 1 ---

N = 0.23 mm  
H = +2, D' = 1

$$\begin{aligned} T &= N - [(H - D') \times 0.01] + 3.00 \\ &= 0.23 - [((+2) - 1) \times 0.01] + 3.00 \\ &= 0.23 - [(2 - 1) \times 0.01] + 3.00 \\ &= 0.23 - [1 \times 0.01] + 3.00 \\ &= 0.23 - 0.01 + 3.00 \\ &= 3.22 \text{ mm} \end{aligned}$$

The correct washer is 3.21 mm thick.

Ex. 2 ---

N = 0.35 mm  
H = -1, D' = 2

$$\begin{aligned} T &= N - [(H - D') \times 0.01] + 3.00 \\ &= 0.35 - [((-1) - 2) \times 0.01] + 3.00 \\ &= 0.35 - [(-1 - 2) \times 0.01] + 3.00 \\ &= 0.35 - [(-3) \times 0.01] + 3.00 \\ &= 0.35 - [-0.03] + 3.00 \\ &= 0.35 + 0.03 + 3.00 \\ &= 3.38 \end{aligned}$$

The correct washer is 3.39 mm thick.

Ex. 3 ---

N = 0.27 mm  
H = 0, D' = 0

$$\begin{aligned} T &= N - [(H - D') \times 0.01] + 3.00 \\ &= 0.27 - [(0 - 0) \times 0.01] + 3.00 \\ &= 0.27 - [0 \times 0.01] + 3.00 \\ &= 0.27 - 0 + 3.00 \\ &= 3.27 \end{aligned}$$

The correct washer is 3.27 mm thick.

**Note:** If values signifying H and D' are not given, regard them as zero and compute. After assembly, check to see that tooth contact is correct. If not, readjust.

For the tooth contact pattern, see Figs. PD-28 through PD-32 for Contact Pattern.

**Note:** Pinion height adjustment can be made in a unit of 1/100 mm (4/10,000 in) by selecting either 0.05 mm (0.0020 in) or 0.07 mm (0.0028 in) shim in above chart.

4. Fit determined pinion height adjusting washer in drive pinion, and press fit rear bearing inner race in it using Base ST30901000.

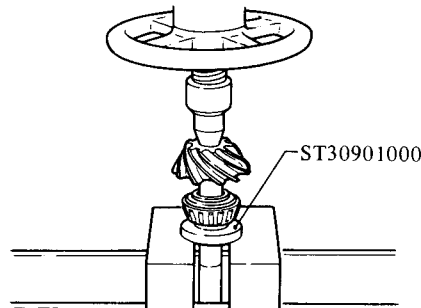

PD092

Fig. PD-60 Pressing Rear Bearing Inner Race

**Note:** Insert washer into pinion with the chamfered side towards gear.

5. Lubricate pinion front and rear bearings. Install drive pinion in gear carrier into which drive pinion bearing spacer and washer, front bearing inner race and front pilot bearing spacer, moreover, pilot bearing and front oil seal are fitted. Fit front oil seal using Gear Carrier Front Oil Seal Drift KV38100500.

6. Fit companion flange on drive pinion, and secure it in position by tightening nut to specified torque confirming preload.

**Note:** If drive pinion lock nut is worn, replace it.

⊕: **Drive pinion nut**  
**186 - 216 N·m**  
**(19 - 22 kg·m,**  
**137 - 159 ft·lb)**  
**Drive pinion preload**  
**(with oil seal)**  
**1.13 - 1.72 N·m**  
**(11.5 - 17.5 kg·cm,**  
**10.0 - 15.2 in·lb)**

## ADJUSTMENT OF SIDE BEARING WASHERS

1. If the hypoid gear set, carrier, differential case or side bearing has been replaced with new part, adjust the side bearing preload with adjusting washer. The required thicknesses of the left and right washers can be obtained from the following formulas:

$$\begin{aligned} T_1 &= (A - C + D - H') \times 0.01 + E + 2.05 \\ T_2 &= (B - D + H') \times 0.01 + F + G + 1.95 \end{aligned}$$

Where,

T<sub>1</sub> : Required thickness of left side washer (mm).

T<sub>2</sub> : Required thickness of right side washer (mm).

A & B : Figure marked on the gear carrier. See Fig. PD-62.

C & D : Figure marked on the differential case. See Fig. PD-63.

E & F : These are differences in width of left or right side bearing against the standard width (21.00 mm).

If bearing width is 20.82 mm, this figure will be as follows:

$$21.00 - 20.82 = 0.18 \text{ (mm)}$$

G : This is the difference in thickness of side spacer against the standard width (8.10 mm). If spacer width is 8.02 mm, this figure will be as follows.

H' : Figure marked on ring gear. See Fig. PD-64.

$$8.10 - 8.02 = 0.08 \text{ (mm)}$$

Figures for A, B, C and D are dimensional variations in a unit of 1/100 mm against each standard measurement.

To measure width of side bearing, see differential case assembly procedure.

Before calculation, determine "G" value by measuring spacer thickness. If spacer is deformed or scratched, replace.

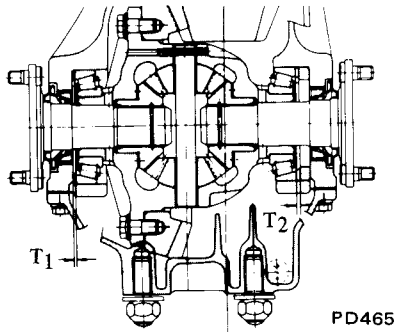

PD465

Fig. PD-61 Thickness of Left and Right Washers

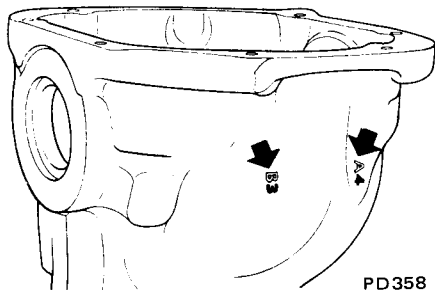

PD358

Fig. PD-62 A & B Figures

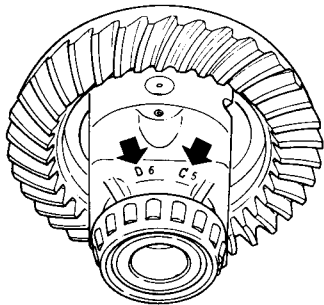

PD359

Fig. PD-63 C & D Figures

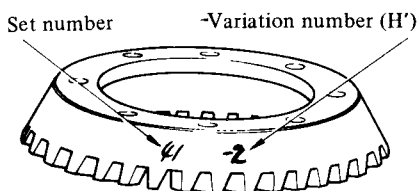

PD190

Fig. PD-64 Variation Number on Ring Gear

## Example of calculation

Ex. 1 ---

$$\begin{aligned} A &= 4, B = 3, C = 5, D = 6 \\ E &= 0.18 \text{ mm}, F = 0.15 \text{ mm} \\ G &= 0.08 \text{ mm}, H' = -2 \end{aligned}$$

Left side:

$$\begin{aligned} T_1 &= (A - C + D - H') \times 0.01 + E \\ &\quad + 2.05 \\ &= [4 - 5 + 6 - (-2)] \times 0.01 \\ &\quad + 0.18 + 2.05 \\ &= 7 \times 0.01 + 0.18 + 2.05 \\ &= 0.07 + 0.18 + 2.05 \\ &= 2.30 \end{aligned}$$

The correct washer is 2.30 mm thick.

Right side:

$$\begin{aligned} T_2 &= (B - D + H') \times 0.01 + F + G \\ &\quad + 1.95 \\ &= [3 - 6 + (-2)] \times 0.01 + 0.15 \\ &\quad + 0.08 + 1.95 \\ &= (-5) \times 0.01 + 0.15 + 0.08 \\ &\quad + 1.95 \\ &= -0.05 + 0.15 + 0.08 + 1.95 \\ &= 2.13 \end{aligned}$$

The correct washer is 2.15 mm thick.

Ex. 2 ---

$$\begin{aligned} A &= 6, B = 6, C = 5, D = 3 \\ E &= 0.17 \text{ mm}, F = 0.22 \text{ mm} \\ G &= 0.10 \text{ mm}, H' = 2 \end{aligned}$$

Left side:

$$\begin{aligned} T_1 &= (A - C + D - H') \times 0.01 + E \\ &\quad + 2.05 \\ &= (6 - 5 + 3 - 2) \times 0.01 + 0.17 \\ &\quad + 2.05 \\ &= 2 \times 0.01 + 0.17 + 2.05 \\ &= 0.02 + 0.17 + 2.05 \\ &= 2.24 \end{aligned}$$

The correct washer is 2.25 mm thick.

Right side:

$$\begin{aligned} T_2 &= (B - D + H') \times 0.01 + F + G \\ &\quad + 1.95 \\ &= (6 - 3 + 2) \times 0.01 + 0.22 \\ &\quad + 0.10 + 1.95 \\ &= 5 \times 0.01 + 0.22 + 0.10 \\ &\quad + 1.95 \\ &= 0.05 + 0.22 + 0.10 + 1.95 \\ &= 2.32 \end{aligned}$$

The correct washer is 2.30 mm thick.

Note: If values signifying A, B, C and D are not given, regard them as zero and compute.

After assembly, check to see that preload and backlash are correct. If not, readjust.

2. Install differential case assembly with side bearing outer races into carrier.

3. Insert left and right side bearing preload adjusting washers in place between side bearings and housing.

4. Drive in side bearing spacer between R.H. washer and housing with Side Bearing Spacer Drift KV38100600. If too great or too small a driving force is required, check to be sure that calculation and side bearing width are correct.

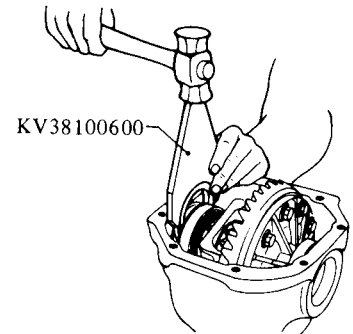

PD361

Fig. PD-65 Driving Spacer Into Place

Note: When driving spacer into place, be careful not to tilt side bearing outer race to either side.

5. Align mark on bearing cap with that on carrier and install bearing cap on carrier. And tighten bolts to specified torque.

⊕ : Side bearing cap bolts  
88 - 98 N·m  
(9.0 - 10.0 kg·m,  
65 - 72 ft·lb)

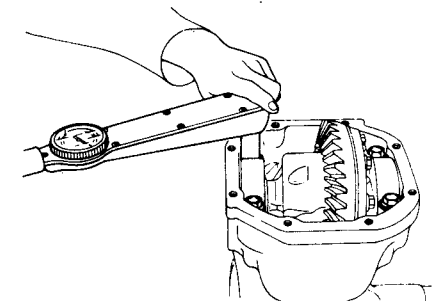

PD362

Fig. PD-66 Tightening Side Bearing Cap

6. Measure ring gear-to-drive pinion backlash with a dial indicator.

If it is below the specified value, replace left washer with a thinner one and right washer with a thicker one. If it is over it, replace left washer with a thicker one and right washer with a thinner one.

**Note:** To maintain correct preload at all times, do not change total thickness of washers.

**Ring gear-to-drive pinion backlash:**  
**0.13 - 0.18 mm**  
**(0.0051 - 0.0071 in)**

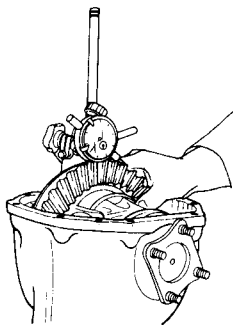

PD341

*Fig. PD-67 Measuring Backlash of Ring Gear and Pinion*

Incidentally a decrease or increase in thickness of washers causes change in ring gear-to-pinion backlash.

Thus, check for proper backlash.

7. Check and adjust the tooth contact pattern of ring gear and drive pinion.

- (1) Thoroughly clean ring and drive pinion gear teeth.
  - (2) Paint ring gear teeth lightly and evenly with a mixture of powdered ferric oxide and oil of a suitable consistency to produce a contact pattern.
  - (3) Rotate pinion through several revolutions in the forward and reverse direction until a definite contact pattern is developed on ring gear.
  - (4) If contact pattern is incorrect, readjust thickness of adjusting washer.
- Be sure to completely wipe off red lead upon completion of adjustment.
- (5) Incorrect teeth contact pattern can be adjusted in the following manner.

### Contact pattern

#### a. Heel contact

To correct, increase thickness of pinion height adjusting washer in order

to bring drive pinion close to ring gear.

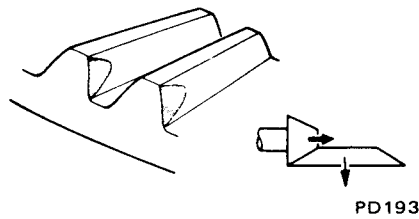

PD193

*Fig. PD-68 Heel Contact*

#### b. Toe contact

To correct, reduce thickness of pinion height adjusting washer in order to make drive pinion move away from ring gear.

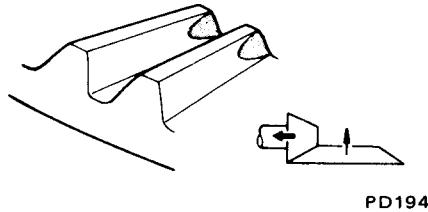

PD194

*Fig. PD-69 Toe Contact*

#### c. Flank contact

Adjust in the same manner as in b.

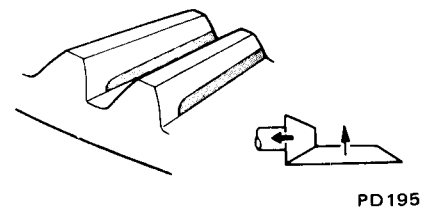

PD195

*Fig. PD-70 Flank Contact*

#### d. Face contact

Adjust in the same manner as in a.

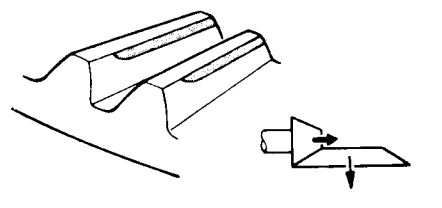

PD196

*Fig. PD-71 Face Contact*

#### e. Correct tooth contact

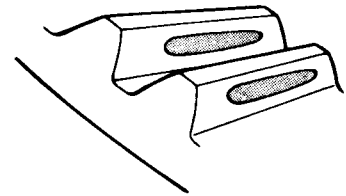

PD197

*Fig. PD-72 Correct Contact*

**Note:** Change in thickness of adjusting washer is accompanied by change in backlash. Check it when installing gear.

8. Install rear cover.

Ⓣ : Rear cover attaching bolts

**16 - 24 N-m**  
**(1.6 - 2.4 kg-m,**  
**12 - 17 ft-lb)**

9. Apply grease to cavity at sealing lips of oil seal.

Press side oil seal into carrier with Gear Carrier Side Oil Seal Drift KV38100200.

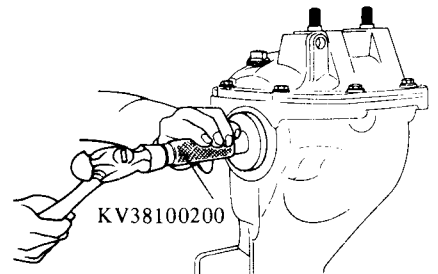

PD363

*Fig. PD-73 Installing Side Oil Seal*

10. Install side flange on carrier. Engage spline in side flange with that in side gear and apply light hammer blows until side flange circlip is fitted into groove in side flange.

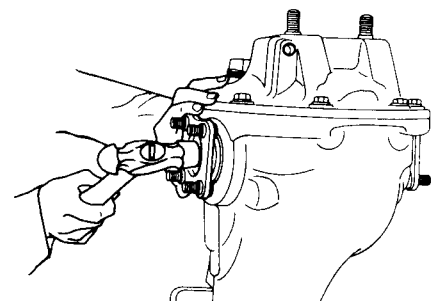

PD364

*Fig. PD-74 Installing Side Flange*

**Note:**

- The length of side flanges differs for their locations. Install the shorter flange on the left side (ring gear) and the longer one on the right side.
- Be careful not to scratch oil seal lips with side flange.

## INSTALLATION

Install in the reverse order of removal.

- Position differential carrier onto suspension member, and temporarily tighten it with four bolts.
- Fit rear cover to mounting insulator nuts ①. See Fig. PD-36.

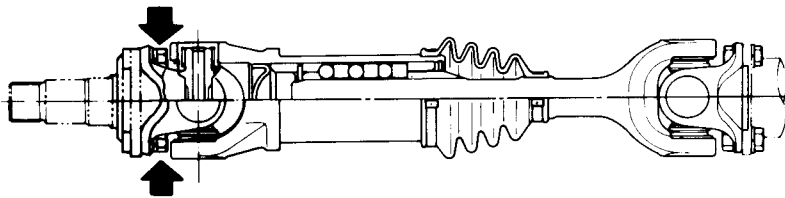

PD468

Fig. PD-75 Tightening Side Flange Fixing Bolt

- ① : Side flange fixing bolts  
 49 - 59 N·m  
 (5.0 - 6.0 kg·m,  
 36 - 43 ft·lb)

- Install drive shaft (tripod drive shaft).
- Join drive shafts with companion flanges of rear axle shafts and tighten connecting bolts.

- T : Drive shaft to axle shaft bolts
- Except tripod drive shaft**  
 49 - 59 N·m  
 (5.0 - 6.0 kg·m,  
 36 - 43 ft·lb)
- Tripod drive shaft**  
 27 - 37 N·m  
 (2.8 - 3.8 kg·m,  
 20 - 27 ft·lb)

- Install other parts in the reverse manner of removal.
- Fill with correct gear oil.

**Note: Gear oil capacity:**  
 1.3 liter (2-3/4 US pt, 2-1/4 Imp pt)

- Ⓣ : Rear cover to mounting insulator nuts  
 88 - 118 N·m  
 (9.0 - 12.0 kg·m,  
 65 - 87 ft·lb)

- Secure differential carrier onto rear suspension member with four bolts.

- Ⓣ : Differential carrier to suspension member bolts  
 59 - 78 N·m  
 (6.0 - 8.0 kg·m,  
 43 - 58 ft·lb)

- Install flange yokes together with drive shafts to differential carrier, and tighten side flange fixing bolts to specified torque (except tripod drive shaft).

- Fit companion flange on drive pinion, and secure it in position by tightening nut to specified torque confirming the following preload, with Drive Pinion Flange Wrench ST31530000.

- Ⓣ : Drive pinion nut  
 186 - 216 N·m  
 (19 - 22 kg·m,  
 137 - 159 ft·lb)
- Pinion bearing preload (with oil seal):**  
 1.13 - 1.72 N·m  
 (11.5 - 17.5 kg·cm,  
 10.0 - 15.2 in·lb)

- At companion flange bolt hole**  
 30.4 - 48.1 N  
 (3.1 - 4.9 kg,  
 6.8 - 10.8 lb)

- Reinstall propeller shaft in reverse order of removal, and fill up with gear oil.

## SIDE OIL SEAL

Side oil seal is replaced as follows:

- Disconnect drive shaft on the gear carrier side.
- Drive side flange out with pry bar.

**Note:** Hold side bearing flange with hand to prevent it from jumping out of carrier.

- Remove oil seal.
- Set in new oil seal with Gear Carrier Side Oil Seal Drift KV38100200.

**Note:** Apply grease to cavity between oil seal lips.

- Install side flange on carrier. Engage spline in side flange with that in side gear and apply light hammer blows until side flange circlip is fitted into groove in side flange.
- Join drive shaft with side flange and tighten nuts.

- Ⓣ : Drive shaft to axle shaft bolts  
 49 - 59 N·m  
 (5.0 - 6.0 kg·m,  
 36 - 43 ft·lb)

**Note:** Be careful not to scratch oil seal lips with side flange.

## REPLACEMENT OF OIL SEALS

Replacement of oil seals with differential gear carrier assembly installed on the car.

### FRONT OIL SEAL

Procedures are as follows:

- Drain gear oil.
- Raise car on hoist.
- Remove insulator, exhaust tube and main muffler mounting bolt to free them from car body.
- Detach propeller shaft.
- Remove drive pinion nut.
- Extract companion flange with a suitable puller.
- Remove oil seal.
- Set new oil seal in position with Gear Carrier Front Oil Seal Drift KV38100500. Apply grease to cavity between seal lips.

## SERVICE DATA AND SPECIFICATIONS (S.D.S.)

### PROPELLER SHAFT

#### GENERAL SPECIFICATIONS

Unit: mm (in)

Applied model	S130 (2 seater)		GS130 (2+2 seater)	
	L28E engine	L28ET engine	L28E engine	L28ET engine
Type	2S63A	2S71A	2S63A	2S71A
Length	580 (22.83)	575 (22.64)	780 (30.71)	775 (30.51)
Outer diameter	63.5 (2.500)	75 (2.95)	63.5 (2.500)	75 (2.95)

#### SERVICE DATA

Permissible dynamic unbalance	gr-cm (oz-in)	35 (0.49)/5,800 rpm
Axial play of spider journal	mm (in)	0 (0)
Journal swinging torque	N·m (kg-cm, in-lb)	0.3 - 1.5 (3 - 15, 2.6 - 13.0)

#### TIGHTENING TORQUE

Unit		N·m	kg-m	ft-lb
Shaft to companion flange bolts	2S63A	34 - 44	3.5 - 4.5	25 - 33
	2S71A	39 - 44	4.0 - 4.5	29 - 33

### DIFFERENTIAL CARRIER

#### GENERAL SPECIFICATIONS

Applied model	S130 (2 seater)				GS130 (2+2 seater)		
	L28E engine		L28ET engine		L28E engine		L28ET engine
	Deluxe	GL		GL	M/T	A/T	M/T A/T
	M/T A/T	M/T	A/T	M/T A/T			
Type	R180	R200	R180	R200	R200	R180	R200
Gear ratio (number of teeth)	3.545 (39/11)	3.900 (39/10)	3.545 (39/11)	3.545 (39/11)	3.900 (39/10)	3.545 (39/11)	3.545 (39/11)
Drive pinion preload adjusted by	Washer						
Oil capacity (about) liter (US pt, Imp pt)	1.0 (2-1/8, 1-3/4)	1.3 (2-3/4, 2-1/4)	1.0 (2-1/8, 1-3/4)	1.3 (2-3/4, 2-1/4)	1.0 (2-1/8, 1-3/4)	1.3 (2-3/4, 2-1/4)	1.3 (2-3/4, 2-1/4)

# Propeller Shaft & Differential Carrier

## SERVICE DATA

Type		R180		R200	
Drive pinion					
Preload	N·m (kg·cm, in·lb)	1.0 - 1.3 (10 - 13, 8.7 - 11.3)		1.0 - 1.3 (10 - 13, 8.7 - 11.3)	
(without oil seal)		0.9 - 1.7 (9 - 17, 7.8 - 14.8)		1.13 - 1.72 (11.5 - 17.5, 10.0 - 15.2)	
(with oil seal)					
Thickness of pinion height adjusting washer	mm (in)	3.09 (0.1217)	3.39 (0.1335)	3.09 (0.1217)	3.39 (0.1335)
		3.12 (0.1228)	3.42 (0.1346)	3.12 (0.1228)	3.42 (0.1346)
		3.15 (0.1240)	3.45 (0.1358)	3.15 (0.1240)	3.45 (0.1358)
		3.18 (0.1252)	3.48 (0.1370)	3.18 (0.1252)	3.48 (0.1370)
		3.21 (0.1264)	3.51 (0.1382)	3.21 (0.1264)	3.51 (0.1382)
		3.24 (0.1276)	3.54 (0.1394)	3.24 (0.1276)	3.54 (0.1394)
		3.27 (0.1287)	3.57 (0.1406)	3.27 (0.1287)	3.57 (0.1406)
		3.30 (0.1299)	3.60 (0.1417)	3.30 (0.1299)	3.60 (0.1417)
		3.33 (0.1311)	3.63 (0.1429)	3.33 (0.1311)	3.63 (0.1429)
		3.36 (0.1323)	3.66 (0.1441)	3.36 (0.1323)	3.66 (0.1441)
					0.05 (0.0020)
					0.07 (0.0028)
Length of pinion bearing adjusting spacer	mm (in)	52.20 (2.0551)		55.10 (2.1693)	
		52.40 (2.0630)		55.40 (2.1811)	
		52.60 (2.0709)		55.70 (2.1929)	
		52.80 (2.0787)		56.00 (2.2047)	
		53.00 (2.0866)		56.25 (2.2146)	
		53.20 (2.0945)			
Thickness of pinion bearing adjusting washer	mm (in)	2.30 - 2.32 (0.0906 - 0.0913)		3.80 - 3.82 (0.1496 - 0.1504)	
		2.32 - 2.34 (0.0913 - 0.0921)		3.82 - 3.84 (0.1504 - 0.1512)	
		2.34 - 2.36 (0.0921 - 0.0929)		3.84 - 3.86 (0.1512 - 0.1520)	
		2.36 - 2.38 (0.0929 - 0.0937)		3.86 - 3.88 (0.1520 - 0.1528)	
		2.38 - 2.40 (0.0937 - 0.0945)		3.88 - 3.90 (0.1528 - 0.1535)	
		2.40 - 2.42 (0.0945 - 0.0953)		3.90 - 3.92 (0.1535 - 0.1543)	
		2.42 - 2.44 (0.0953 - 0.0961)		3.92 - 3.94 (0.1543 - 0.1551)	
		2.44 - 2.46 (0.0961 - 0.0969)		3.94 - 3.96 (0.1551 - 0.1559)	
		2.46 - 2.48 (0.0969 - 0.0976)		3.96 - 3.98 (0.1559 - 0.1567)	
		2.48 - 2.50 (0.0976 - 0.0984)		3.98 - 4.00 (0.1567 - 0.1575)	
		2.50 - 2.52 (0.0984 - 0.0992)		4.00 - 4.02 (0.1575 - 0.1583)	
		2.52 - 2.54 (0.0992 - 0.1000)		4.02 - 4.04 (0.1583 - 0.1591)	
		2.54 - 2.56 (0.1000 - 0.1008)		4.04 - 4.06 (0.1591 - 0.1598)	
		2.56 - 2.58 (0.1008 - 0.1016)		4.06 - 4.08 (0.1598 - 0.1606)	
		2.58 - 2.60 (0.1016 - 0.1024)		4.08 - 4.10 (0.1606 - 0.1614)	
Side gear and pinion mate					
Thickness of side gear thrust washer	mm (in)	0.75 - 0.80 (0.0295 - 0.0315)		0.75 - 0.80 (0.0295 - 0.0315)	
		0.80 - 0.85 (0.0315 - 0.0335)		0.80 - 0.85 (0.0315 - 0.0335)	
		0.85 - 0.90 (0.0335 - 0.0354)		0.85 - 0.90 (0.0335 - 0.0354)	
Pinion mate-to-side gear backlash (or clearance between side gear and thrust washer)	mm (in)	For tripod drive shaft Less than 0.15 (0.0059)		For tripod drive shaft Less than 0.15 (0.0059)	
		Except tripod drive shaft 0.10 - 0.20 (0.0039 - 0.0079)		Except tripod drive shaft 0.10 - 0.20 (0.0039 - 0.0079)	

## Propeller Shaft & Differential Carrier

Type		R180		R200	
Ring gear					
Ring gear-to-drive pinion backlash	mm (in)	0.10 - 0.20 (0.0039 - 0.0079)		0.13 - 0.18 (0.0051 - 0.0071)	
Thickness of side retainer shim (R180) or side bearing adjusting washer (R200)	mm (in)	0.20 (0.0079)		2.00 (0.0787)	2.35 (0.0925)
		0.25 (0.0098)		2.05 (0.0807)	2.40 (0.0945)
		0.30 (0.0118)		2.10 (0.0827)	2.45 (0.0965)
		0.40 (0.0157)		2.15 (0.0846)	2.50 (0.0984)
		0.50 (0.0197)		2.20 (0.0866)	2.55 (0.1004)
				2.25 (0.0886)	2.60 (0.1024)
				2.30 (0.0906)	
Side bearing standard width	mm (in)	20.0 (0.787)		21.0 (0.827)	

### TIGHTENING TORQUE

Type	R180			R200		
	N·m	kg·m	ft·lb	N·m	kg·m	ft·lb
Drive pinion nut	167 - 196	17 - 20	123 - 145	186 - 216	19 - 22	137 - 159
Ring gear bolt [using Locktite (stud lock) or equivalent]	88 - 98	9.0 - 10.0	65 - 72	59 - 69	6.0 - 7.0	43 - 51
Side bearing cap bolt	—	—	—	88 - 98	9.0 - 10.0	65 - 72
Side retainer bolt	8.8 - 11.8	0.9 - 1.2	6.5 - 8.7	—	—	—
Rear cover fixing bolt	39 - 49	4.0 - 5.0	29 - 36	16 - 24	1.6 - 2.4	12 - 17
Rear cover to mounting insulator nut	59 - 78	6.0 - 8.0	43 - 58	88 - 118	9.0 - 12.0	65 - 87
Differential carrier to suspension member bolt	59 - 78	6.0 - 8.0	43 - 58	59 - 78	6.0 - 8.0	43 - 58
Companion flange to propeller shaft fixing bolt	34 - 44	3.5 - 4.5	25 - 33	34 - 44	3.5 - 4.5	25 - 33
Side flange to drive shaft fixing nut	—	—	—	49 - 59	5.0 - 6.0	36 - 43
Side yoke fitting bolt	31 - 42	3.2 - 4.3	23 - 31	—	—	—
Filler and drain plug	39 - 59	4 - 6	29 - 43	39 - 59	4 - 6	29 - 43

## TROUBLE DIAGNOSES AND CORRECTIONS

### PROPELLER SHAFT

Condition	Probable cause	Corrective action
Vibration at medium or high speed	Worn or damaged universal joint needle bearing. Unbalance due to bent or dented propeller shaft. Loose propeller shaft installation. Worn transmission rear extension bushing. Undercoating or mud on the shaft causing unbalance. Tire unbalance. Balance weights missing.	Replace propeller shaft assembly.  Replace propeller shaft assembly.  Retighten. Replace. Clean shaft.  Balance wheel and tire assembly. Replace.
Knocking sound on propeller shaft while starting or noise while coasting.	Worn or damaged universal joint. Worn sleeve yoke and main shaft spline. Loose propeller shaft installation.	Replace propeller shaft assembly. Replace propeller shaft assembly. Retighten.
Scraping noise	Dust cover on sleeve yoke rubbing on transmission rear extension. Dust cover on companion flange rubbing on differential carrier.	Straighten dust cover to remove interference.

### DIFFERENTIAL CARRIER

When gear carrier is suspected causing noise, it is advisable to make a thorough test to determine whether the noise originates in the tires, road

surface, exhaust, universal joint, propeller shaft, wheel bearings, engine, transmission, or gear carrier. Noise which originates in other places cannot

be corrected by adjustment or replacement of parts in the rear axle assembly.







Condition	Probable cause	Corrective action
Noise during driving and/or coasting	Shortage of oil.  Incorrect tooth contact between ring gear and drive pinion.  Incorrect backlash between ring gear and drive pinion.  Seized or damaged ring gear and drive pinion.  Seized, damaged or broken drive pinion bearing.  Seized, damaged or broken side bearing.  Loose bolts or nuts fixing ring gear, side bearing caps, etc.	Supply gear oil. Rebuild gear carrier if necessary.  Adjust tooth contact or replace the hypoid gear set.  Adjust backlash or replace the hypoid gear set if necessary.  Replace the hypoid gear set.   Replace the pinion bearing and faulty parts.  Replace the side bearing and faulty parts.  Tighten to specified torque, and replace faulty parts.

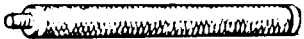
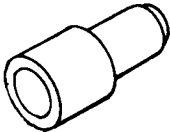

## Propeller Shaft & Differential Carrier

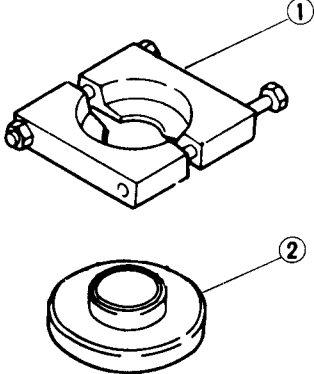
Condition	Probable cause	Corrective action
Noise on turns.	<p>Seized, damaged or broken side and pinion gears.</p> <p>Seized, damaged or broken side gear and pinion thrust washer.</p> <p>Pinion gears too tight on their shaft.</p> <p>Interference between side flange and differential case.</p>	<p>Replace faulty parts.</p> <p>Replace faulty parts.</p> <p>Replace faulty parts.</p> <p>Repair the part responsible for interference, or replace the side flange and differential case.</p>
Knocking sound during starting or gear shifting	<p>Excessive backlash.</p> <p style="padding-left: 20px;">Incorrect backlash of ring gear-to-drive pinion or side gear-to-pinion gear.</p> <p style="padding-left: 20px;">Worn gears or case.</p> <p style="padding-left: 20px;">Worn side flange and side gear spline.</p> <p>Pinion bearing under preload.</p> <p>Loose drive pinion nut.</p> <p>Loose bolts or nuts fixing ring gear, side bearing caps, etc.</p>	<p>Adjust backlash.</p> <p>Replace worn parts.</p> <p>Replace worn parts.</p> <p>Adjust preload.</p> <p>Repair or replace.</p> <p>Tighten or replace if necessary.</p>
Seizure or breakage.	<p>Shortage of oil or use of unsuitable oil.</p> <p>Excessively small backlash.</p> <p>Incorrect adjustment of bearings or gears.</p> <p>Severe service due to excessive loading, improper use of clutch.</p> <p>Loose bolts and nuts, such as ring gear bolts.</p>	<p>Replace faulty parts.</p> <p>Adjust backlash and replace as required.</p> <p>Replace faulty parts.</p> <p>Replace faulty parts.</p> <p>Replace faulty parts.</p>
Oil leakage.	<p>Worn-out, damaged or improperly driven front oil seal, or bruised, dented or abnormally worn slide face of companion flange.</p> <p>Worn, damaged or improperly driven side oil seal, or bruised, dented or abnormally worn slide flange.</p> <p>Loose rear cover bolts.</p> <p>Worn rear cover gasket.</p> <p>Loose filler or drain plug.</p> <p>Clogged or damaged breather.</p>	<p>Replace the faulty oil seal. Ammend the affected flange with sandpaper or replace if necessary.</p> <p>Treat as above.</p> <p>Tighten the bolts to specified torque.</p> <p>Replace the faulty gasket with new one.</p> <p>Tighten the plug.</p> <p>Repair or replace.</p>

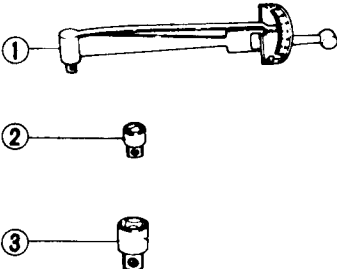
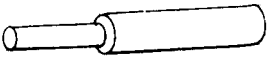
## SPECIAL SERVICE TOOLS

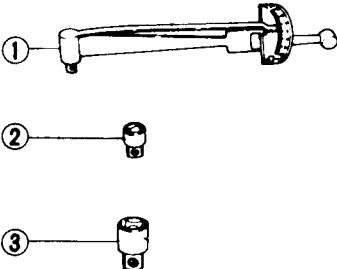
Tool number & tool name	Kent-Moore No.	Tool number & tool name	Kent-Moore No.
	Reference page or Fig. No.		Reference page or Fig. No.
	Unit application		Unit application
ST30611000 Drift 	J 25742-1	ST30720000 Gear carrier front oil seal drift 	J 25751
	Page PD-6 Page PD-9 Page PD-16		Page PD-8 Page PD-11
	*		R180
ST30613000 Drift 	J 25742-3	ST3090S000 Drive pinion rear bearing inner race puller set ① ST30031000 Puller ② ST30901000 Base 	① J25733-1 ② —
	Page PD-16		Fig. PD-10 Fig. PD-20 Fig. PD-48 Fig. PD-60
	R200 (Front)		*
ST30621000 Drift 	—	ST3127S000 Preload gauge ① GG91030000 Torque wrench ② HT62940000 Socket adapter ③ HT62900000 Socket adapter 	See J 25765 ① J25765 ② — ③ —
	Page PD-9 Page PD-16		Fig. PD-16 Fig. PD-40 Fig. PD-56
	*		*
ST30650001 Pilot bearing drift 	J 25749	ST30701000 Drive pinion outer race drift 	See J 25765 ① J25765 ② — ③ —
	Page PD-4		Fig. PD-16 Fig. PD-40 Fig. PD-56
	R180		*
ST30701000 Drive pinion outer race drift 	J 25742-2	ST3127S000 Preload gauge ① GG91030000 Torque wrench ② HT62940000 Socket adapter ③ HT62900000 Socket adapter 	See J 25765 ① J25765 ② — ③ —
	Page PD-6		Fig. PD-16 Fig. PD-40 Fig. PD-56
	R180 (Front)		*

\*: Applicable to all S130 series models

# Propeller Shaft & Differential Carrier

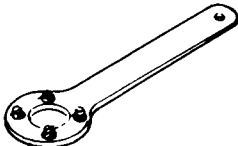
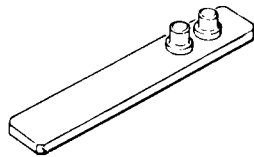
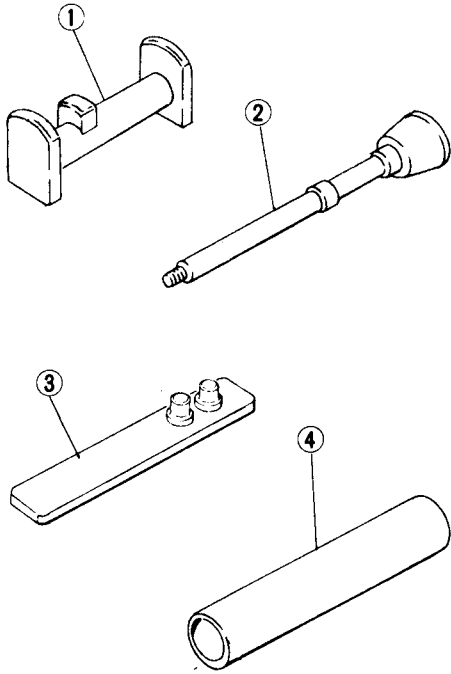
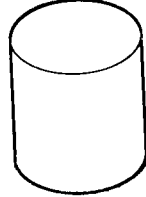
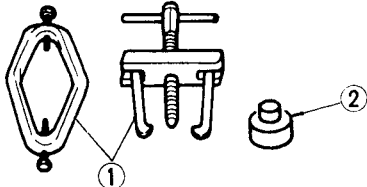
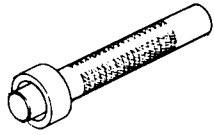
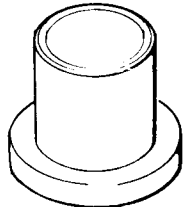
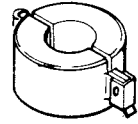
Tool number & tool name	Kent-Moore No.	Tool number & tool name	Kent-Moore No.
	Reference page or Fig. No.		Reference page or Fig. No.
	Unit application		Unit application
ST31530000 Drive pinion flange wrench  	J25774-A	ST31852000 Stopper (R180)  	—
	Page PD-11 Page PD-20 Fig. PD-9 Fig. PD-45		Fig. PD-15
	*		R180
ST3121S000 Height gauge assembly  ① ST31211000 Height gauge ② ST31212000 Dummy shaft ③ ST31213000 Stopper (R160 only) ④ ST31214000 Collar  	See J 25269-01	ST32501000 Weight block  	J 25407-3
	① See J25269-B ② See J25269-B ③ See J25269-B ④ See J25269-B		Fig. PD-13 Fig. PD-53
	Fig. PD-17 Fig. PD-18	ST3306S001 Diff. side bearing puller set ① ST33051001 Body ② ST33061000 Adapter  	*
	R180		① — ② J25797-2  Fig. PD-11 Fig. PD-14 Fig. PD-50 Fig. PD-54
		ST33230000 Diff. side bearing drift  	J 25805-01
			Fig. PD-14
			R180
ST31851000 Spacer (R180)  	See J25269-B	ST33270000 Gear carrier side oil seal drift  	J 25809
	Fig. PD-17		Page PD-11
	R180		R180

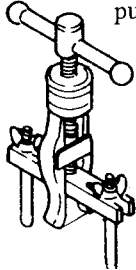
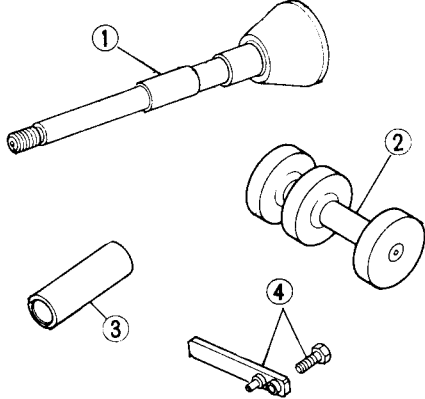
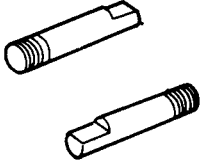
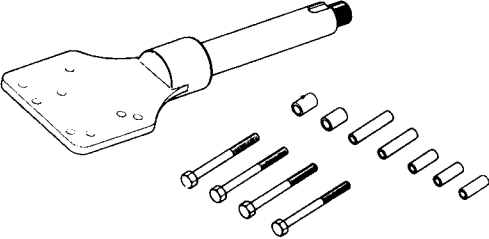
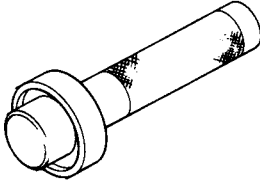
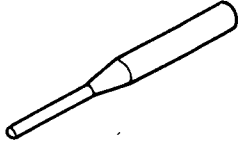
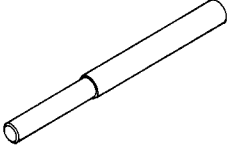
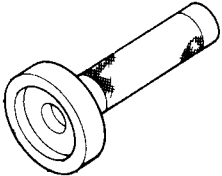
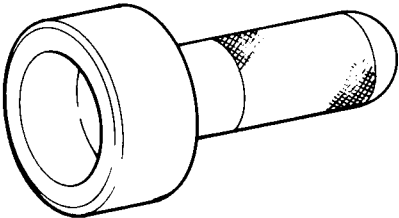

\*: Applicable to all S130 series models

# Propeller Shaft & Differential Carrier

Tool number & tool name	Kent-Moore No.	Tool number & tool name	Kent-Moore No.
	Reference page or Fig. No.		Reference page or Fig. No.
	Unit application		Unit application
ST33290001 Side bearing outer race puller 	J 25810	KV381001S0 Drive pinion setting gauge set (R200) ① KV38100110 Dummy shaft ② KV38100120 Height gauge ③ KV38100130 Collar ④ KV38100140 Stopper 	—
	Fig. PD-8		Page PD-16 Fig. PD-55 Fig. PD-57 Fig. PD-58
	R180		
ST33720000 Gear carrier side retainer guide (R160, R180) 	J 25817		
	Fig. PD-25		
	R180		R200
KV38100800 Diff. attachment 	—	KV38100300 Diff. side bearing drift 	—
	Fig. PD-6 Fig. PD-39		Fig. PD-54
	*		R200
KV31100300 Solid punch 	J25689-A	KV38100401 Pilot bearing drift 	—
	Page PD-15 Fig. PD-12		Fig. PD-47
	*		R200
KV38100200 Gear carrier side oil seal drift 	—	KV38100500 Gear carrier front oil seal drift 	—
	Page PD-20 Fig. PD-73		Page PD-17 Page PD-20
	R200		R200

\*: Applicable to all S130 series models

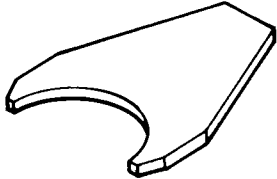
# Propeller Shaft & Differential Carrier

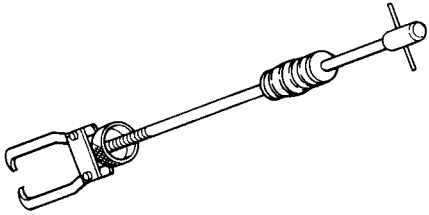
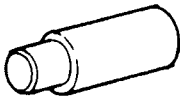
Tool number & tool name	Kent-Moore No.	Tool number & tool name	Kent-Moore No.
	Reference page or Fig. No.		Reference page or Fig. No.
	Unit application		Unit application
KV38100600 Side bearing spacer drift  	—	KV38102000 Master gauge [21.0 mm (0.827 in)]  	—
	Fig. PD-65		Fig. PD-53
	R200		R200
KV38101900 Master gauge [20.0 mm (0.787 in)]  	—	HT72400000 Slide hammer  	—
	Fig. PD-13		Fig. PD-44
	R180		R200
ST33710000 Diff. side retainer attachment  	—		
	Fig. PD-7		
	R180		

\*: Applicable to all S130 series models