

ENGINE LUBRICATION & COOLING SYSTEMS

SECTION LC

CONTENTS

LC

ENGINE LUBRICATION SYSTEM	LC- 2	THERMOSTAT	LC- 7
LUBRICATION CIRCUIT	LC- 2	RADIATOR	LC- 8
OIL PUMP	LC- 3	SERVICE DATA AND SPECIFICATIONS (S.D.S.)	LC-10
OIL PRESSURE RELIEF VALVE	LC- 4	ENGINE LUBRICATION SYSTEM	LC-10
ENGINE OIL COOLER (For turbocharger)	LC- 5	ENGINE COOLING SYSTEM	LC-10
LUBRICATING OIL PASSAGE FOR TURBOCHARGER	LC- 5	TROUBLE DIAGNOSES AND CORRECTIONS	LC-11
ENGINE COOLING SYSTEM	LC- 6	LUBRICATION SYSTEM	LC-11
COOLING CIRCUIT	LC- 6	COOLING SYSTEM	LC-11
WATER PUMP	LC- 6	SPECIAL SERVICE TOOL	LC-12

ENGINE LUBRICATION SYSTEM

LUBRICATION CIRCUIT

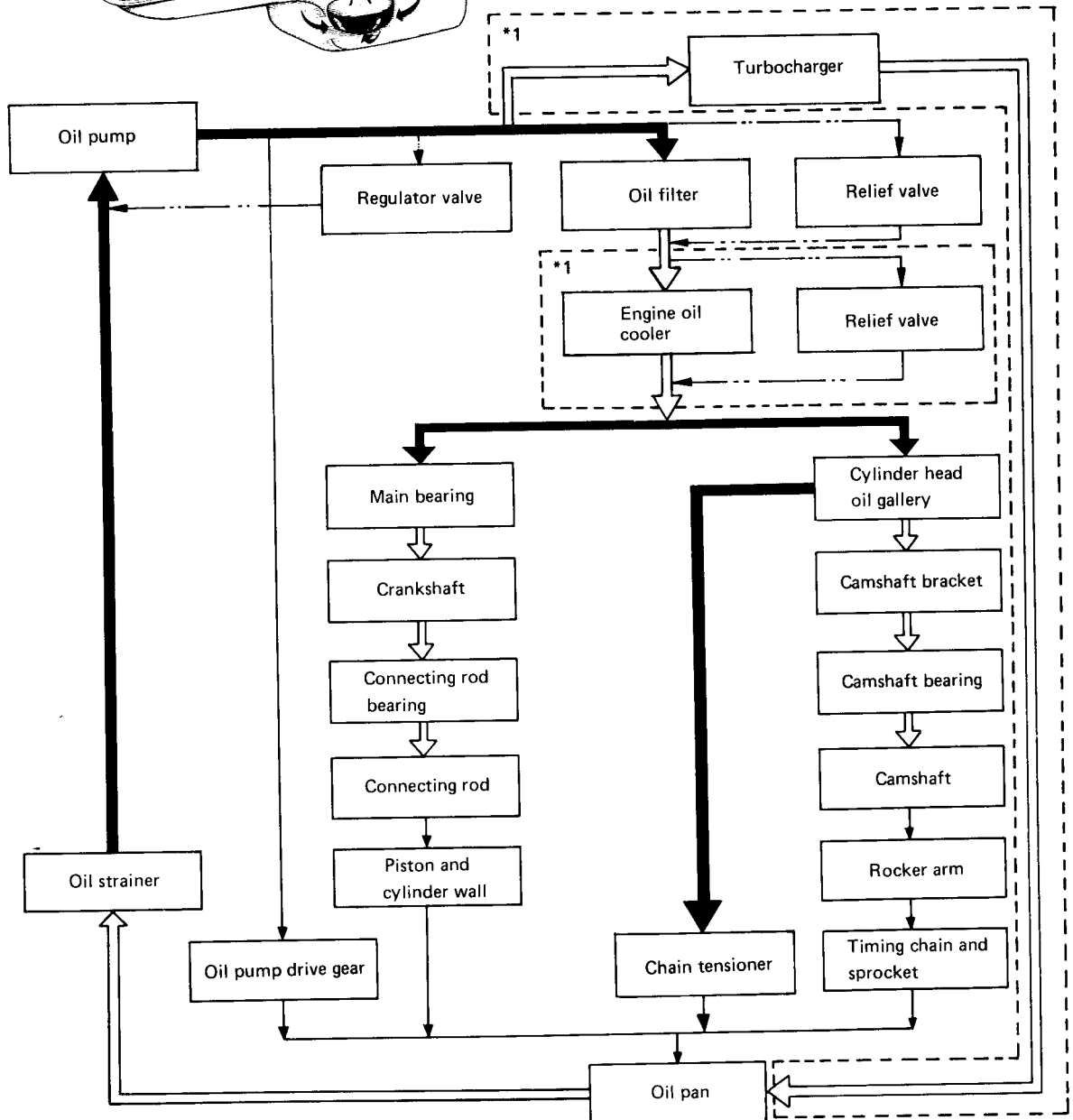
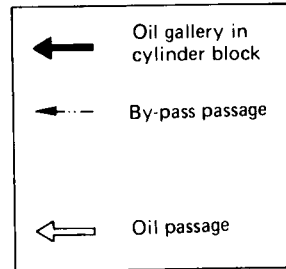
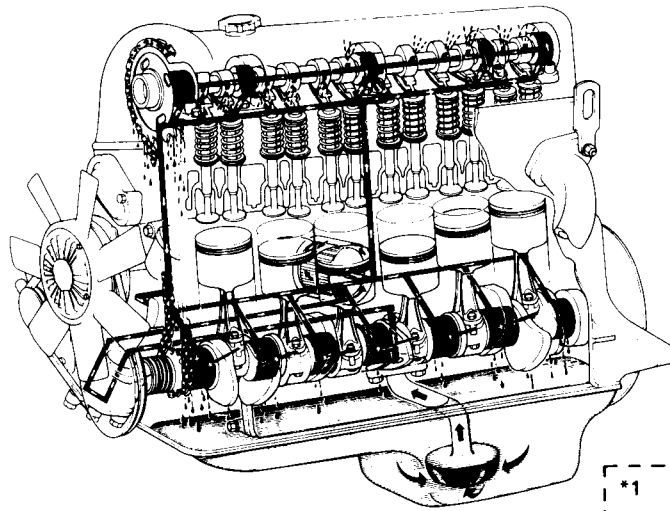

*1 Additional lubrication circuit for turbocharger model

OIL PUMP

REMOVAL

1. Before removing oil pump, turn crankshaft so that No. 1 piston is at T.D.C.

Under this condition, remove distributor cap and ascertain position of rotor head.

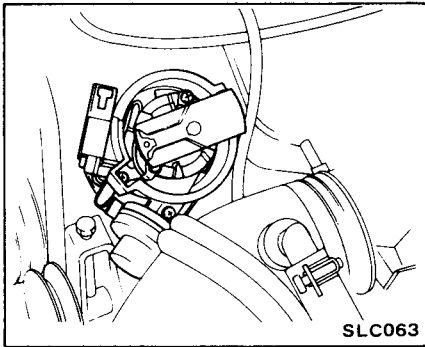

2. Remove under cover.
3. Remove oil pump and drive spindle as an assembly.

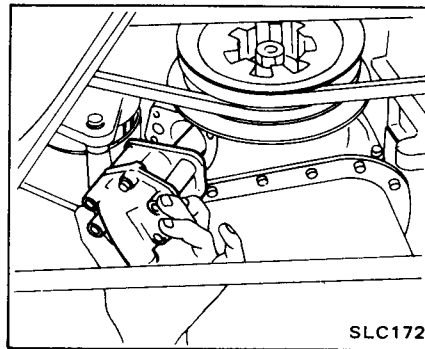

The dot on outer and inner rotor should face toward oil pump body.

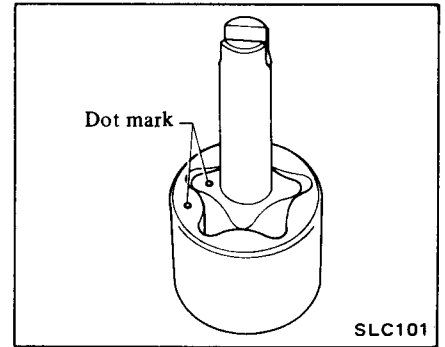

INSPECTION

1. Using a feeler gauge, check the following clearance.

If it exceeds limit, replace rotor set or entire oil pump assembly.

Rotor tip clearance ①:

Less than 0.20 mm (0.0079 in)

Outer rotor to body clearance ②:

Less than 0.50 mm (0.0197 in)

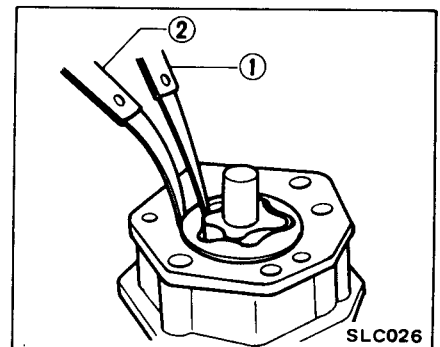

DISASSEMBLY AND ASSEMBLY

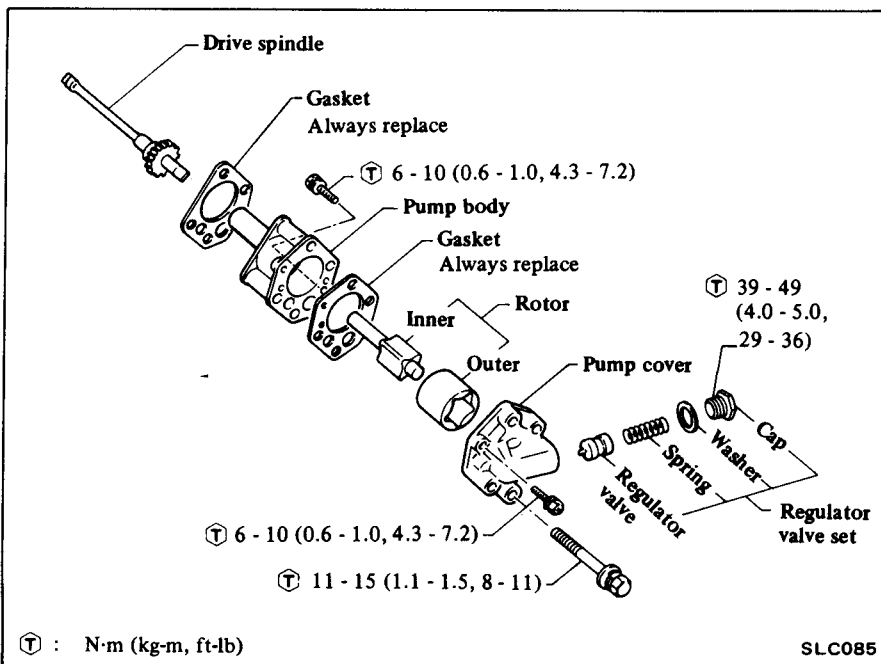

Rotor to straight edge ③:

Less than 0.06 mm (0.0024 in)

Oil pump body to straight edge ④:

Less than 0.03 mm (0.0012 in)

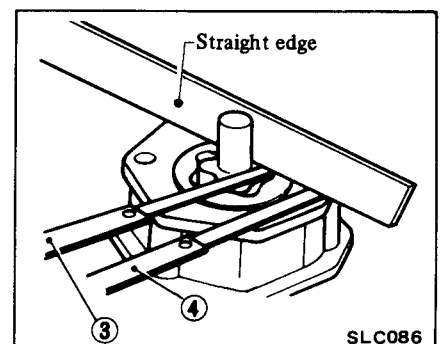

2. Check oil pressure regulator valve sliding surface and valve spring.

If damaged, replace valve set or pump assembly.

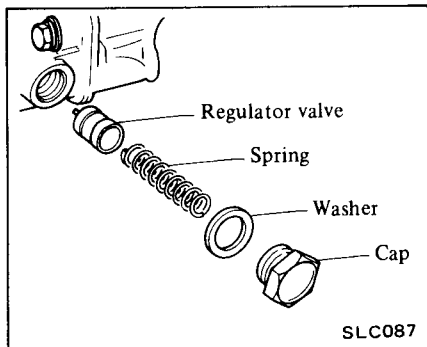

3. Using a new gasket, install oil pump and drive spindle assembly.

Make sure that tip of drive spindle assembly fits distributor fitting hole securely.

Ⓣ : Oil pump mounting bolts
 11 - 15 N·m
 (1.1 - 1.5 kg·m,
 8 - 11 ft·lb)

4. Refill engine with oil.

After installing, run engine for a few minutes, and check for leaks.

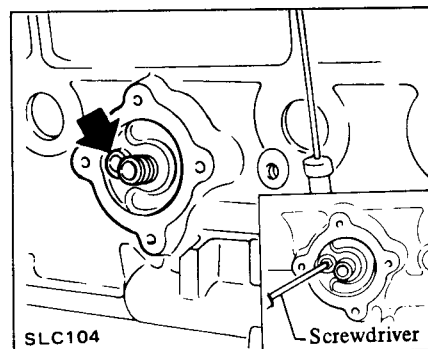

INSTALLATION

1. Make sure that distributor rotor is in the same position as it was before removal.

2. Fill pump housing with engine oil, then align punch mark of drive spindle with hole in oil pump.

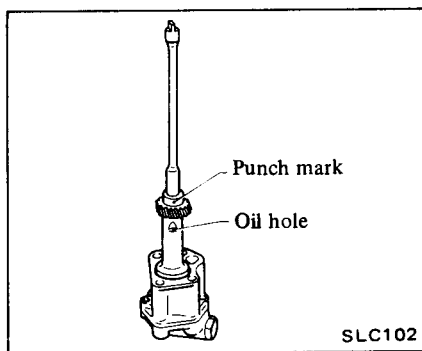

Equipped with oil cooler
 (With turbocharger)

1. Loosen oil filter stud and remove oil filter bracket.
2. Check oil pressure relief valve.

If necessary, replace it as an oil filter bracket assembly.

OIL PRESSURE RELIEF VALVE

INSPECTION

When removing oil filter, check oil pressure relief valve for a cracked or broken valve.

If necessary, remove valve by prying it out with a screwdriver.

Install a new valve by tapping it in place.

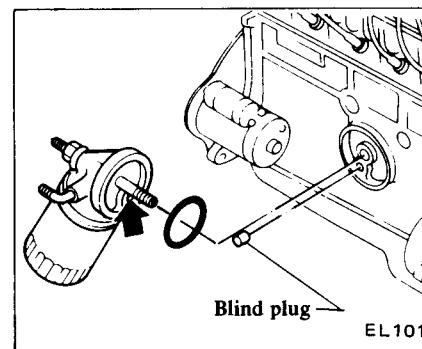

ENGINE OIL COOLER (For turbocharger)

REMOVAL AND INSTALLATION

- When related parts of oil cooler are removed and installed, start engine after installing all parts and make sure that there are no oil leaks in oil passage.
- Check engine oil cooler relief valve in oil filter bracket. If necessary, replace it as an oil filter bracket assembly.

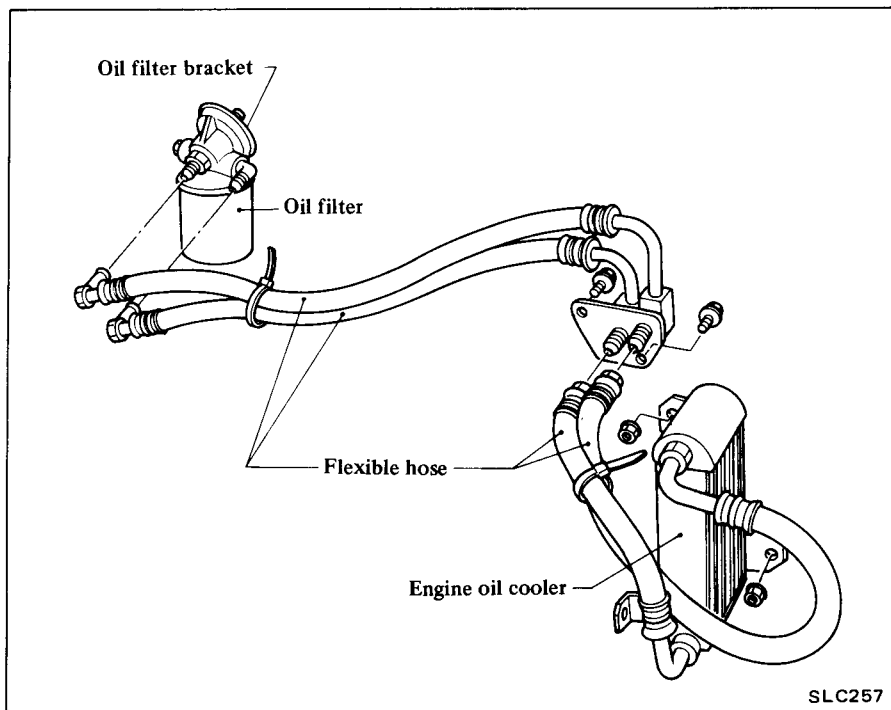

LUBRICATING OIL PASSAGE FOR TURBOCHARGER

- Before removing oil passage, remove auxiliary cooling fan. Refer to Section EF.
- When related parts of oil passage are removed and installed, start engine after installing all parts and make sure that there are no oil leaks in oil passage.

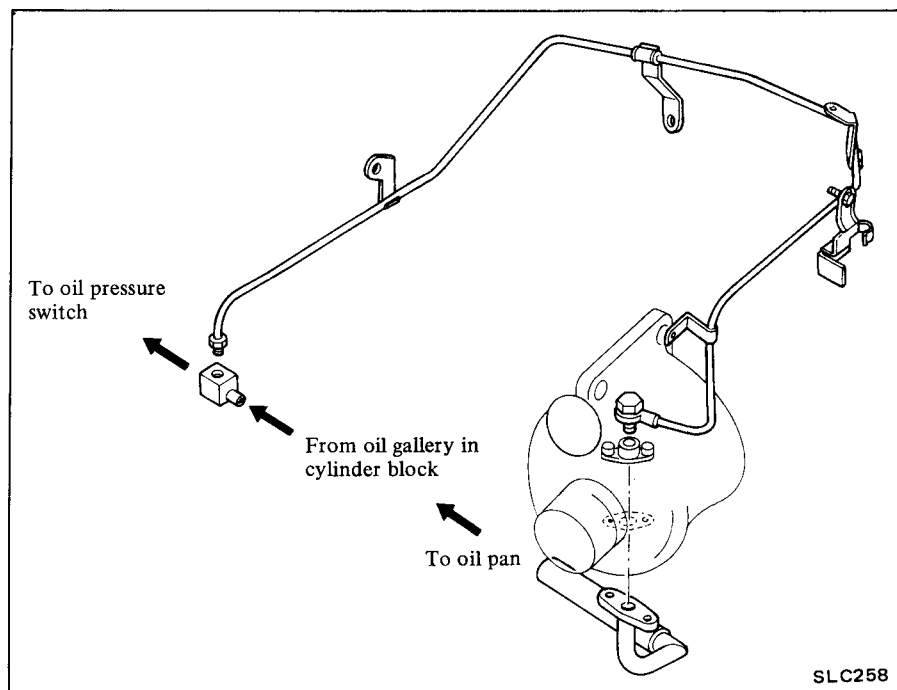

ENGINE COOLING SYSTEM

COOLING CIRCUIT

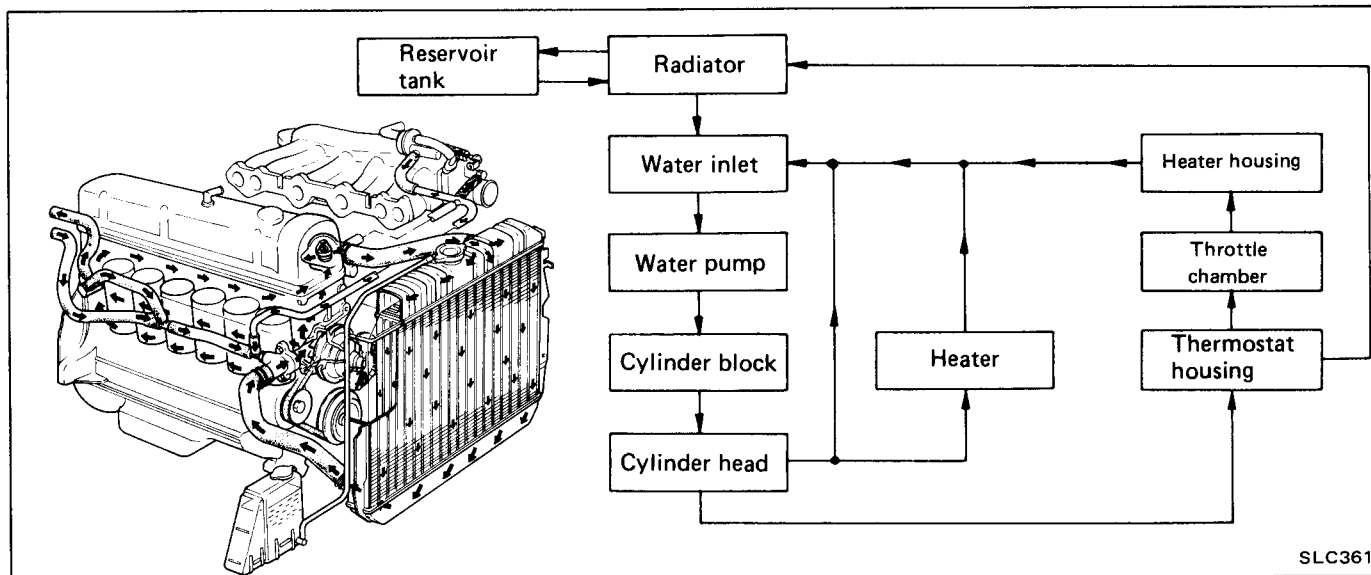

WATER PUMP

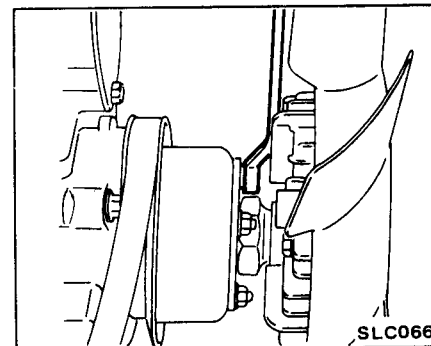
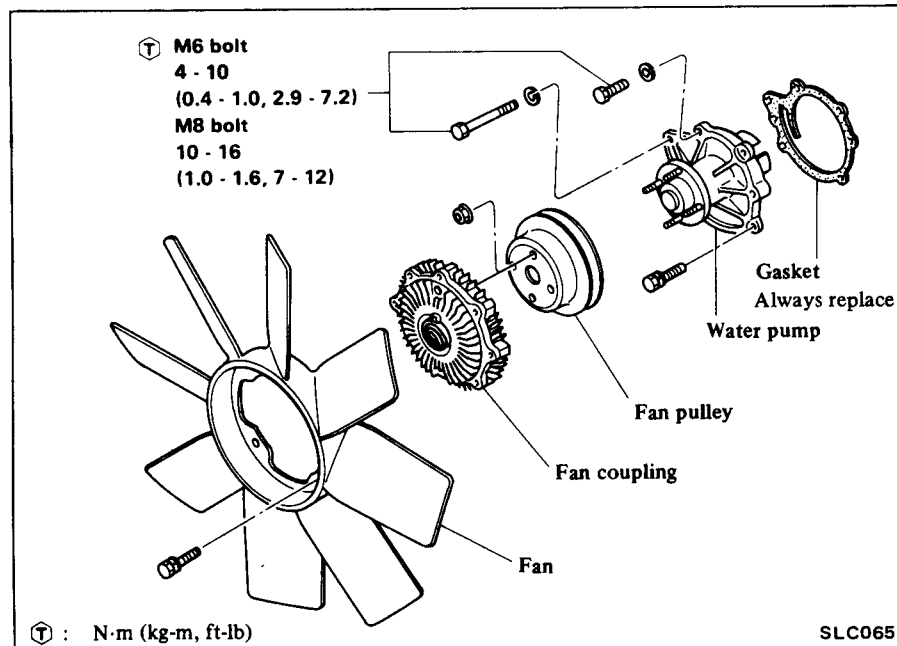

- Loosen fan belt.
- (1) Loosen alternator securing bolts.
- (2) Move the alternator toward the engine.
- Loosen power steering oil pump drive belt.
- Remove fan, fan coupling and fan pulley as an assembly.
- Remove water pump with gasket.

REMOVAL

1. Open radiator drain cock and remove radiator cap, and drain coolant into a suitable container.

WARNING:

To avoid the danger of being scalded, never attempt to drain the coolant when the engine is hot.

- Remove radiator shroud.
- Loosen fan pulley nuts.

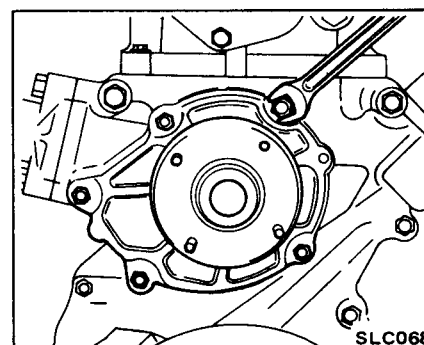

INSPECTION

The water pump and fan coupling cannot be disassembled and should be replaced as a unit.

1. Inspect water pump body and vane for rust or corrosion.

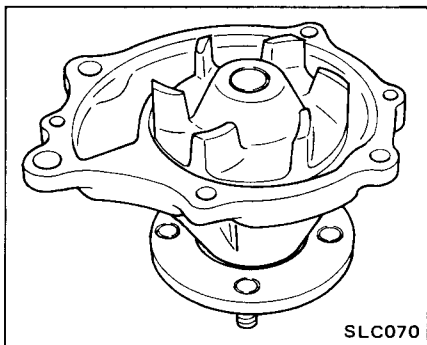

2. Inspect water pump bearing.
Check for excessive end play or rough operation.

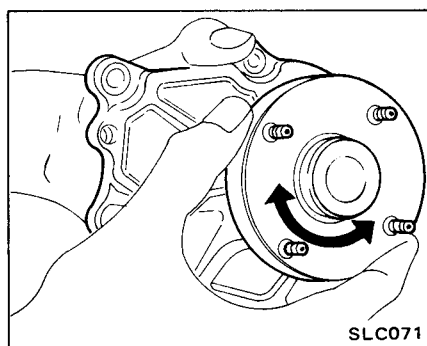

3. Inspect fan coupling.
Check the coupling for oil leakage or bent bimetal.

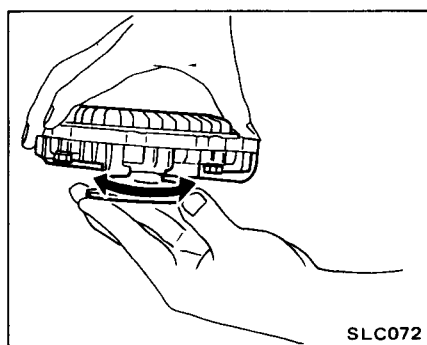

INSTALLATION

1. Install water pump in the reverse order of removal.

Always use new gasket.

2. Adjust fan belt tension.

Refer to section MA.

3. Fill radiator with coolant.

After installing, run engine for a few minutes, and check for leaks.

THERMOSTAT

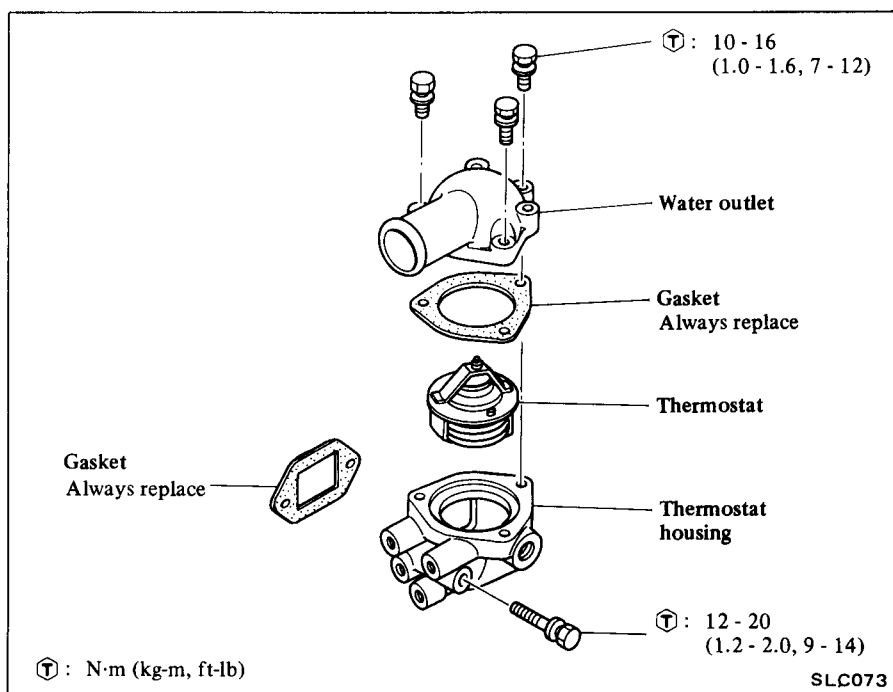

REMOVAL

1. Drain a small amount of coolant partially and disconnect radiator upper hose at water outlet.

WARNING:

To avoid the danger of being scalded, never attempt to drain the coolant when the engine is hot.

2. Remove water outlet and then remove thermostat.

INSPECTION

Inspect thermostat for the following and replace if necessary.

1. Check valve seating condition at ordinary temperature. It should seat tightly.
2. Check valve opening temperature and maximum valve lift. (Refer to S.D.S.)

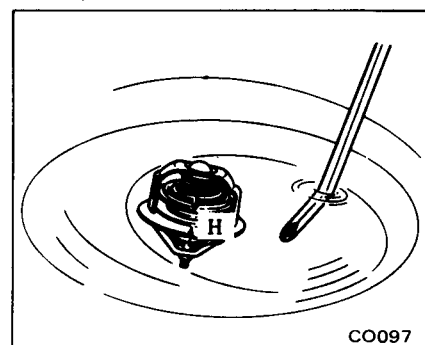

3. Then check if valve closes at 5°C (9°F) below valve opening temperature.

It is necessary to check a new thermostat before installing it.

INSTALLATION

1. Position thermostat on thermostat housing with its air vent hole facing the left side of the engine.

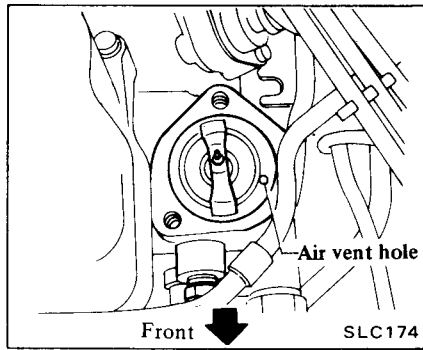

2. Install water outlet with new gasket.

⊕ : Attaching bolt
 10 - 16 N·m
 (1.0 - 1.6 kg·m,
 7 - 12 ft·lb)

3. Connect radiator upper hose and fill radiator with coolant.

After installing, run engine for a few minutes, and check for leaks.

RADIATOR

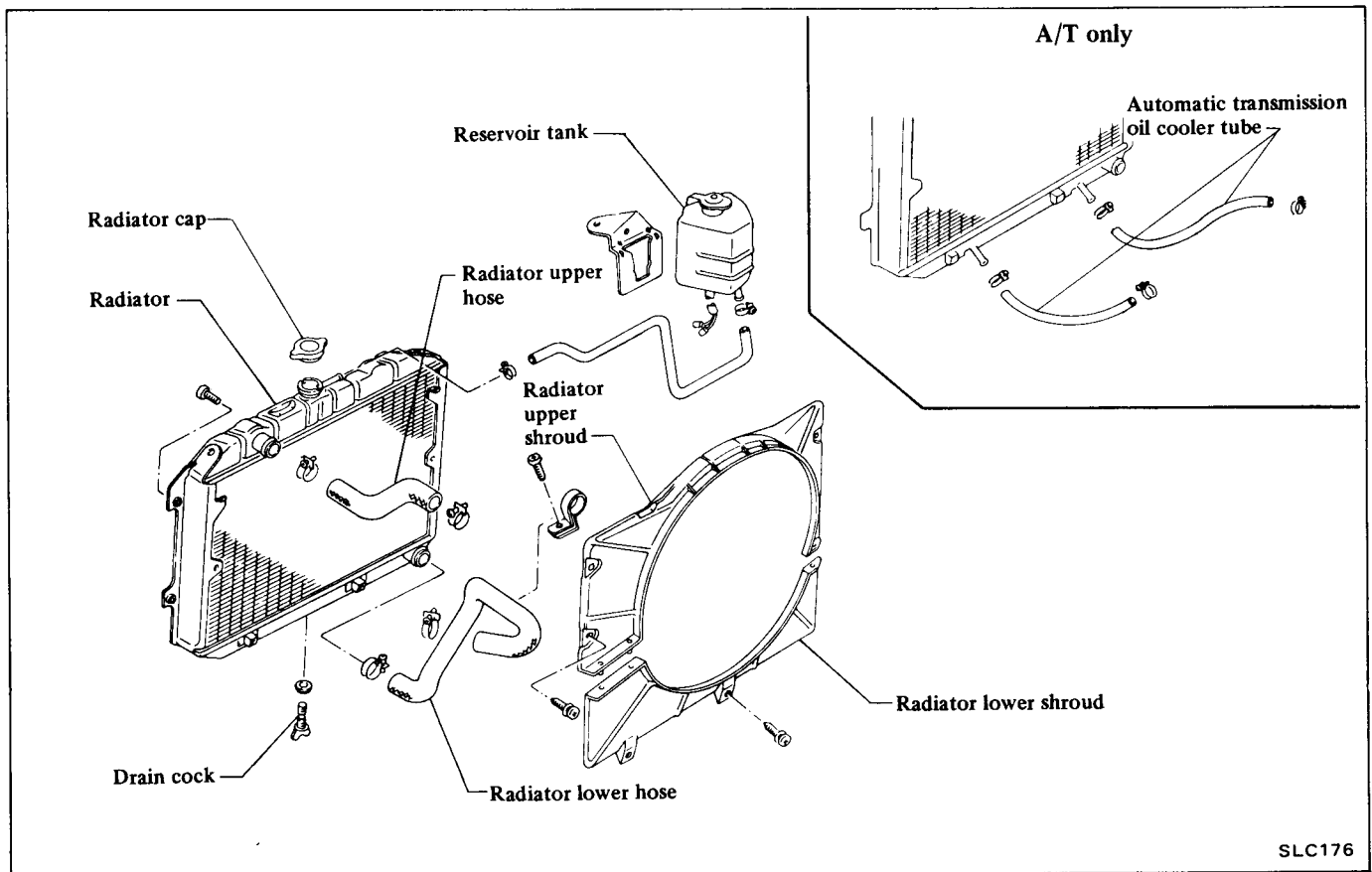

WARNING:

Never remove the radiator cap when the engine is hot; serious burns could be caused by high pressure fluid escaping from the radiator.

Wrap a thick cloth around cap and carefully remove the cap by turning it a quarter turn to allow built-up pressure to escape and then turn the cap all the way off.

INSPECTION

Checking radiator cap

Using cap tester, check the radiator cap relief pressure.

If the pressure gauge drops rapidly and excessively, replace the radiator cap.

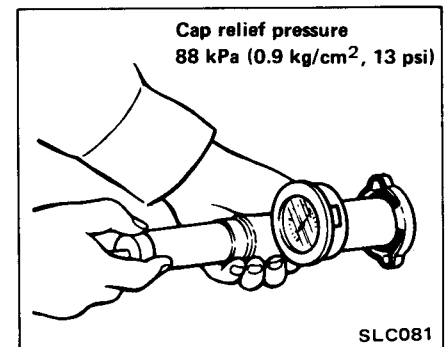

Cap relief pressure
 88 kPa (0.9 kg/cm², 13 psi)

Checking cooling system for leaks

Attach pressure tester. Then pump the tester to the specified pressure.

Check for drop in pressure.

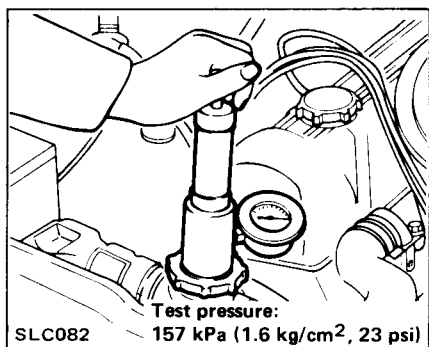

If the pressure drops, check for leaks from hoses, radiator, or water pump.

If no external leaks are found, check heater core, block and head.

REMOVAL AND INSTALLATION

1. Open radiator drain cock and allow to drain into a suitable container.

WARNING:

To avoid the danger of being scalded, never attempt to drain the coolant when the engine is hot.

2. Remove undercover.

3. Remove radiator shroud attaching screws.

4. Disconnect radiator upper hoses at engine side, and disconnect reservoir tank hose.

5. Disconnect radiator lower hose on radiator side.

6. On a car with automatic transmission, disconnect cooler inlet and outlet lines from radiator.

7. Disconnect air cleaner duct hose.

8. Remove air conditioner pipe clip screw (with turbocharger).

9. Remove radiator attaching bolts.

10. Install radiator in the reverse order of removal.

11. Fill radiator with coolant to specified quantity.

After installing, run engine for a few minutes, and check for leaks.

SERVICE DATA AND SPECIFICATIONS (S.D.S.)

ENGINE LUBRICATION SYSTEM

GENERAL SPECIFICATIONS

Lubrication method	Pressed feed flow
Oil pump type	Trochoid type
Oil filter type	Full flow and cartridge type

INSPECTION AND ADJUSTMENT

Oil pump

Unit: mm (in)

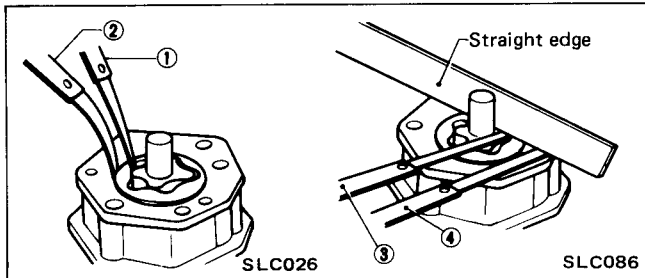

Rotor tip clearance ①	Less than 0.20 (0.0079)
Outer rotor to body clearance ②	Less than 0.50 (0.0197)
Rotor to straight edge ③	Less than 0.06 (0.0024)
Oil pump body to straight edge ④	Less than 0.03 (0.0012)

TIGHTENING TORQUE

Unit	N·m	kg·m	ft·lb
Oil pump mounting bolts	11 - 15	1.1 - 1.5	8 - 11
Oil pump cover bolt	7 - 10	0.7 - 1.0	5.1 - 7.2
Regulator valve cap	39 - 49	4.0 - 5.0	29 - 36
Oil pan drain plug	20 - 29	2.0 - 3.0	14 - 22

ENGINE COOLING SYSTEM

GENERAL SPECIFICATIONS

Cooling method	Water cooling, forced circulation
Water pump type	Centrifugal
Thermostat type	Wax-pellet
Radiator type	Corrugated fin and tube
Fan coupling Fan speed (at water pump speed 4,000 rpm)	2,450/65 - 70 (149 - 158) Less than 1,100/below 50 (122)
Without turbo-charger	
rpm/°C (°F)	2,550 - 2,850/60 - 70 (140 - 158) Less than 1,100/below 50 (122)
With turbo-charger	

INSPECTION AND ADJUSTMENT

Thermostat

	Frigid type	Standard type	Tropical type
Valve opening temperature °C(°F)	88 (190)	82 (180)	76.5 (170)
Max. valve lift mm/°C (in/°F)	8/100 (0.31/212)	8/95 (0.31/203)	8/90 (0.31/194)

Radiator

Cap relief pressure	kPa (kg/cm ² , psi)	88 (0.9, 13)
Leakage test pressure	kPa (kg/cm ² , psi)	157 (1.6, 23)

TIGHTENING TORQUE

Unit	N·m	kg·m	ft·lb	
Water pump bolt	M6	4 - 10	0.4 - 1.0	2.9 - 7.2
	M8	10 - 16	1.0 - 1.6	7 - 12
Water pump pulley stud	6 - 10	0.6 - 1.0	4.3 - 7.2	
Water outlet bolt	10 - 16	1.0 - 1.6	7 - 12	
Thermostat housing	12 - 20	1.2 - 2.0	9 - 14	

TROUBLE DIAGNOSES AND CORRECTIONS**LUBRICATION SYSTEM**

Condition	Probable cause	Corrective action
Oil leakage	Damaged or cracked pump body cover. Oil leakage from gasket and oil seal. Oil leakage from regulator valve. Oil leakage from blind plug. Oil leakage from oil cooler.	Replace. Replace. Tighten or replace. Replace. Tighten or repair.
Decreased oil pressure	Lack of oil in engine oil pan. Dirty oil strainer. Damaged or worn pump rotors. Malfunctioning regulator. Use of poor quality engine oil.	Replenish or add. Clean or replace. Replace. Replace. Replace.
Warning light remains "on" when engine running	Decreased oil pressure. Oil pressure switch unserviceable. Electrical fault.	Previously mentioned. Replace. Check circuit.
Noise	Excessive backlash in pump rotors.	Replace.

COOLING SYSTEM

Condition	Probable cause	Corrective action
Water leakage	Damaged radiator seams. Leaks from heater connections or plugs. Leak from water pump shaft seal. Leak from water temperature gauge. Leaks from gaskets or small cracks. Loose joints. Damaged cylinder head gasket. Cracked cylinder block. Cracked cylinder head. Loose cylinder head bolts.	Repair. Repair. Replace as pump assembly. Tighten. Tighten or use Nissan Cooling System Sealer or equivalent. Tighten. Replace. Check engine oil for contamination and refill as necessary. Replace. Check engine oil in crankcase for mixing with water by pulling oil level gauge. Replace. Tighten.

Condition	Probable cause	Corrective action
Poor circulation	Restriction in system. Insufficient coolant. Inoperative water pump. Loose fan belt. Inoperative thermostat.	Check hoses for crimps, and clear the system of rust and sludge by flushing radiator. Replenish. Replace. Adjust. Replace.
Corrosion	Excessive impurity in water. Infrequent flushing and draining of system.	Use soft, clean water. (rain water is satisfactory). Cooling system should be drained and flushed thoroughly at least twice a year. Permanent antifreeze (Ethylene glycol base) can be used throughout the seasons of a year.
Overheating	Malfunctioning thermostat, radiator cap and fan coupling. Radiator fin choked with mud, chaff, etc. Incorrect ignition and valve timing. Dirty oil and sludge in engine. Inoperative water pump. Loose fan belt. Restricted radiator. Inaccurate temperature gauge. Impurity in water.	Replace. Clean out air passage thoroughly by using air pressure from engine side of radiator. Adjust. Refill. Replace. Adjust. Flush radiator. Replace. Use soft, clean water.
Overcooling	Malfunctioning thermostat. Inaccurate temperature gauge.	Replace. Replace.
Noise	Squeak at water pump mechanical seal. Damaged or worn water pump bearing.	Replace pump assembly. Replace pump assembly.

SPECIAL SERVICE TOOL

Tool number (Kent-Moore No.)	Tool name
ST19320000 (J25664)	Oil filter wrench



SLC036