

## CONTENTS

<b>MODEL VARIATION</b> .....	GI-2	GARAGE JACK AND SAFETY STAND	....	GI-4
<b>IDENTIFICATION NUMBERS</b> .....	GI-3	TOWING	.....	GI-4
ENGINE NUMBER .....	GI-3	TIE-DOWN	.....	GI-5
MANUAL TRANSMISSION NUMBER .....	GI-3	<b>SPECIAL SERVICE TOOLS</b> .....		GI-5
AUTOMATIC TRANSMISSION NUMBER .....	GI-3	<b>TIGHTENING TORQUE OF</b>		
<b>LIFTING POINTS AND TOWING</b> .....	GI-4	<b>STANDARD BOLT</b> .....		GI-6
PANTOGRAPH JACK .....	GI-4			

# MODEL VARIATION

Destination	Model		Engine	Transmission	Differential carrier	Road wheel size ... offset mm (in)	Tire size
U.S.A.	2 seater	HLS130FU	L28E	FS5W71B	R180	5-1/2JJ-14 ... 15 (0.59)	195/70HR14
		HLS130JFU			R200		
		HLS130JAU			R180	6JJ-14* ... 10 (0.39)	
	T-bar roof	KHLS130JFU		FS5W71B	R200		P205/70R14
		KHLS130JAU		3N71B	R180		
	Turbo	KHLS130JATU		L28ET	3N71B	R200	6JJ-15* ... 10 (0.39)
		2+2 seater	HLGS130JFU	L28E	FS5W71B		R180
	HLGS130JAU		3N71B				
	T-bar roof		KHLGS130JFU		FS5W71B	R200	P205/70R14
			KHLGS130JAU		3N71B	R180	
	Turbo	KHLGS130JATU	L28ET	3N71B	R200	6JJ-15* ... 10 (0.39)	P205/60R15
		2 seater	HLS130FN	L28E	FS5W71B	R180	5-1/2JJ-14 ... 15 (0.59)
KHLS130FN	R200						
T-bar roof	KHLS130JFN		3N71B			R180	6JJ-14* ... 10 (0.39)
	KHLS130JAN		L28ET	3N71B	R200	6JJ-15* ... 10 (0.39)	P205/60R15
Turbo	KHLS130JATN			L28E		FS5W71B	R180
	2+2 seater	KHLGS130JFN	3N71B		R180		
T-bar roof		KHLGS130JAN	L28ET	3N71B	R200	6JJ-15* ... 10 (0.39)	P205/60R15
	Turbo	KHLGS130JATN		L28E	3N71B	R200	6JJ-15* ... 10 (0.39)

\* : Aluminum wheel (2-piece type)

Prefix and suffix designations

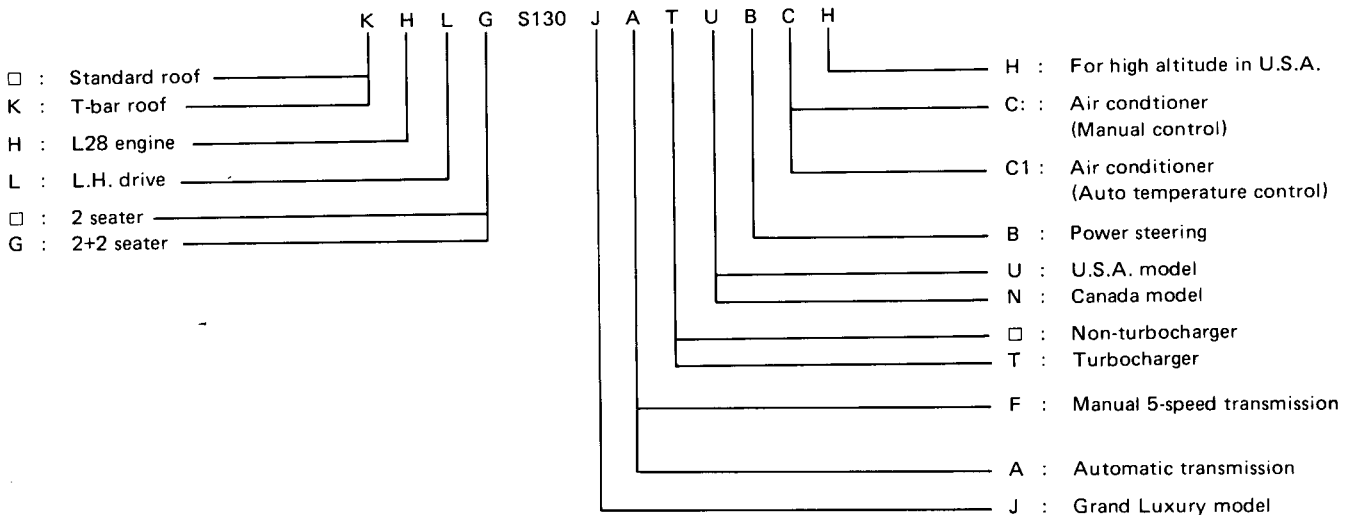

Note:  means no indication.

## IDENTIFICATION NUMBERS

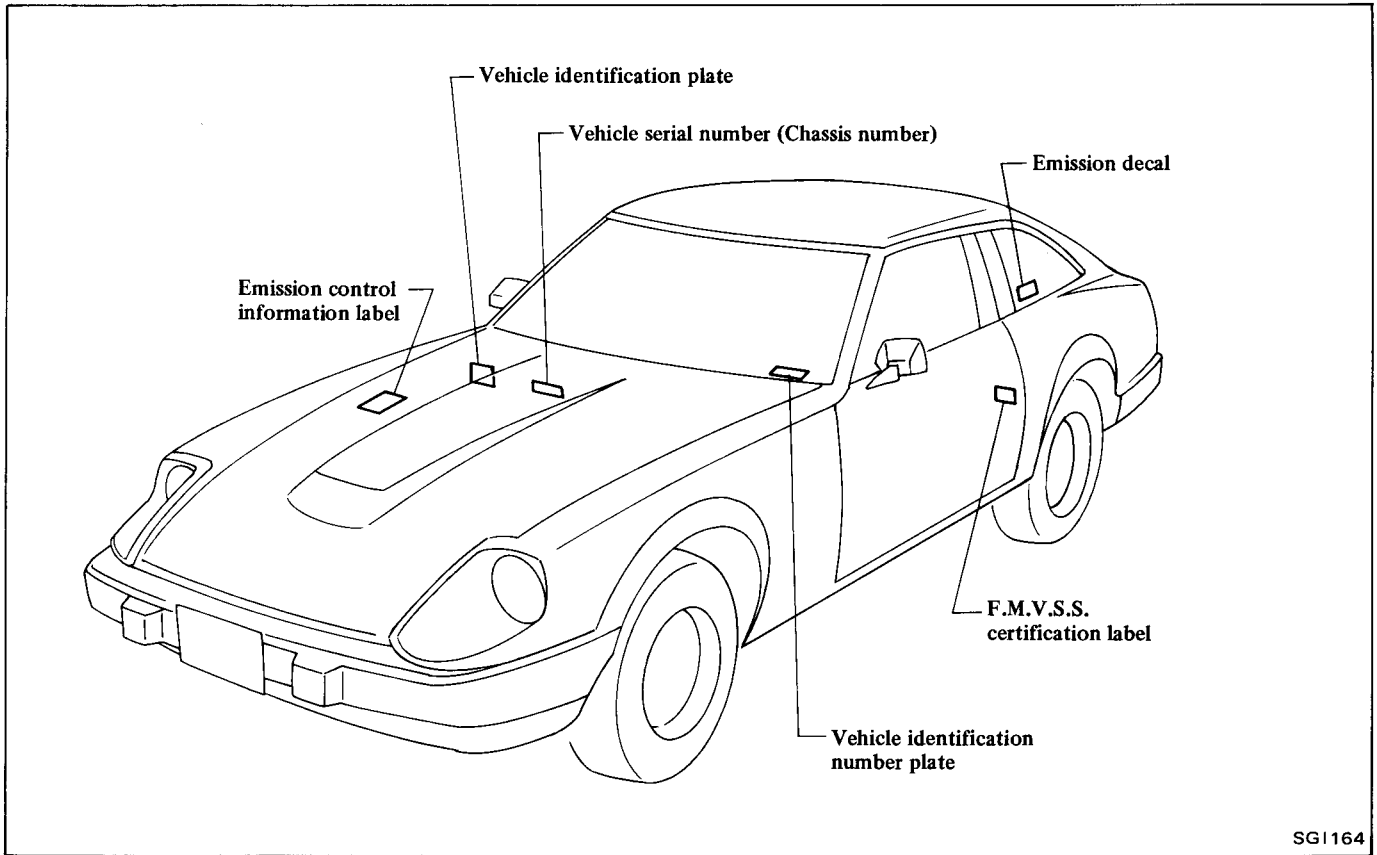

SG1164

### ENGINE NUMBER

The engine serial number is stamped on the right-hand side of the cylinder block.

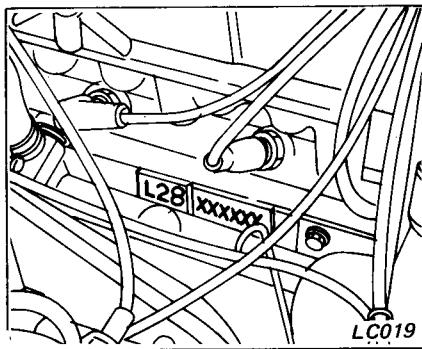

### MANUAL TRANSMISSION NUMBER

The transmission serial number is stamped on the upper front face of the transmission case.

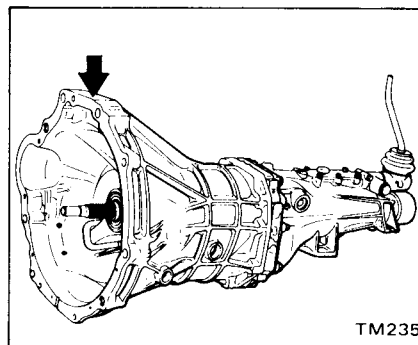

### AUTOMATIC TRANSMISSION NUMBER

The transmission serial number plate is attached to the right-hand side of the transmission case.

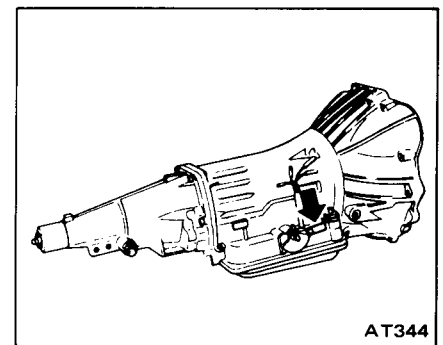

## LIFTING POINTS AND TOWING

### PANTOGRAPH JACK

Place wheel chocks at both the front and back of the wheel diagonally opposite the jack position.

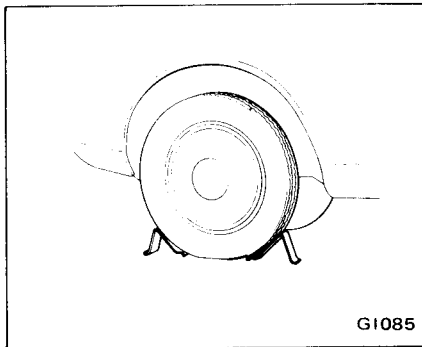

Apply the pantograph jack furnished with the car to the position indicated below in a safe manner.

#### WARNING:

- a. Never get under the car while it is supported only by the jack. Always use safety stands to support frame when you have to get under the car.
- b. Block the wheels diagonally with wheel chocks.

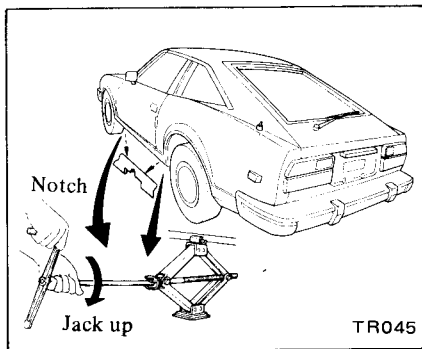

### GARAGE JACK AND SAFETY STAND

#### WARNING:

When carrying out operations with the garage jack, be sure to support the car with safety stands.

### FRONT SIDE

1. When jacking up the front of the car, place the chocks behind the rear wheels to hold them.
2. Apply the garage jack under the front suspension member. Be sure not to lift up the engine oil pan.

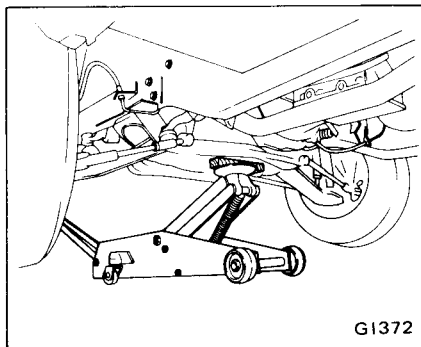

3. Jack up the car gently just high enough to place the safety stands under both the side members. Place the stands at the position indicated in Figure.

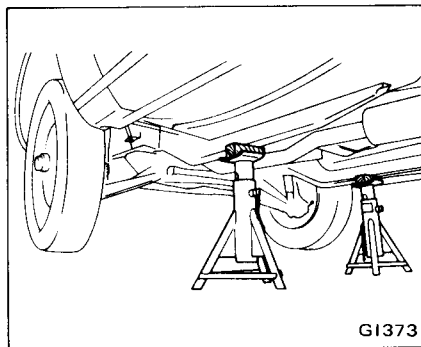

4. Release the jack slowly.

### REAR SIDE

1. When jacking up the rear of the car, place the chocks at the front side of the front wheels to hold them.
2. Apply the garage jack under the differential carrier.

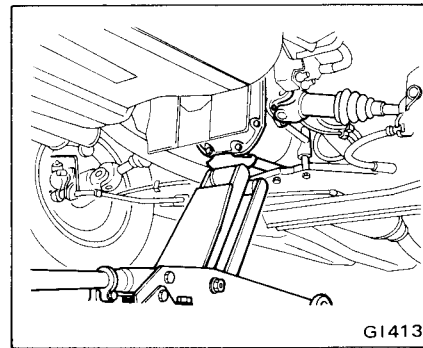

3. Jack up the car gently just high enough to place the safety stands under both the side members. Place the stands at the position indicated in Figure.

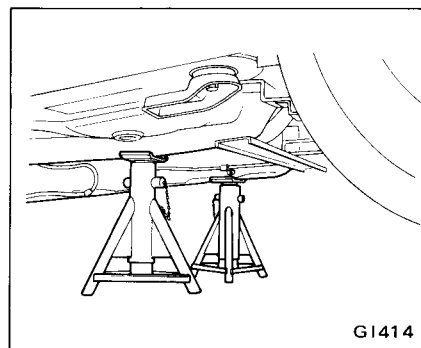

### TOWING

#### CAUTION:

- a. It is necessary to use proper towing equipment, to avoid possible damage to the car during a towing operation. Towing is in accordance with Towing Procedure Manual at dealer side.
- b. All applicable State or Provincial (in Canada) laws and local laws regarding the towing operation must be obeyed.

Front towing hooks are provided on both front side members.

**Front tow: Not recommended with conventional sling-type equipment.**

Rear towing hooks are combined with shock absorber for rear bumper.

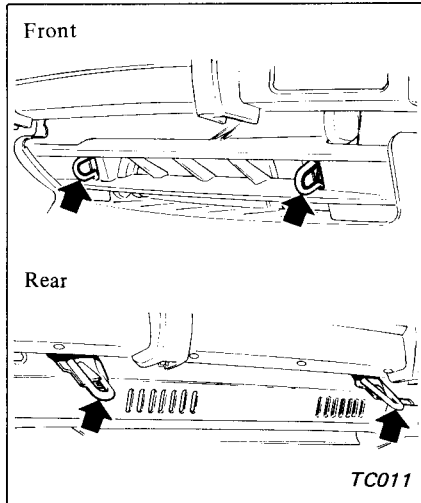

#### CAUTION:

- a. Before towing, make sure that the transmission, axles, steering system and power train are in good order. If any unit is damaged, a dolly must be used.
- b. If the transmission is inoperative, tow the car with the rear wheels off the ground, or with the propeller shaft removed.
- c. When the car is towed with its front wheels on the ground, secure the steering wheel in a straight ahead position with the ignition key turned in "OFF" position.
- d. When towing an automatic transmission model, try to restrict towing speed below 30 km/h (20 MPH) and towing distance less than 30 km (20 miles).  
With manual transmission model, try to restrict towing speed 80 km/h (50 MPH) and towing distance less than 80 km (50 miles).  
If the speed or distance must necessarily be greater, remove the propeller shaft beforehand to prevent damage to the transmission.
- e. Release the parking brake and set the gearshift lever in "Neutral" position before starting to tow the car.

#### TIE-DOWN

Use front and rear towing hooks for tie-down at front and rear sides.

## SPECIAL SERVICE TOOLS

Special Service Tools play very important role in the maintenance of cars. These are essential to the safe, accurate and speedy servicing.

The working times listed in the column under FLAT RATE TIME in FLAT RATE SCHEDULE are com-

puted based on the use of Special Service Tools.

The identification code of maintenance tools is made up of 2 alphabetical letters and 8-digital figures.

The heading two letters roughly classify tools or equipment as:

ST00000000:	Special Service Tool
KV00000000:	Special Service Tool
EM00000000:	Engine Overhauling Machine
GG00000000:	General Gauge
LM00000000:	Garage Tool
HT00000000:	Hand Tool

## TIGHTENING TORQUE OF STANDARD BOLT

Grade	Nominal size	Diameter mm	Pitch mm	Tightening torque		
				N·m	kg·m	ft·lb
4T	M6	6.0	1.0	3 - 4	0.3 - 0.4	2.2 - 2.9
	M8	8.0	1.25	8 - 11	0.8 - 1.1	5.8 - 8.0
			1.0	8 - 11	0.8 - 1.1	5.8 - 8.0
	M10	10.0	1.5	16 - 22	1.6 - 2.2	12 - 16
			1.25	16 - 22	1.6 - 2.2	12 - 16
	M12	12.0	1.75	26 - 36	2.7 - 3.7	20 - 27
1.25			30 - 40	3.1 - 4.1	22 - 30	
M14	14.0	1.5	46 - 62	4.7 - 6.3	34 - 46	
7T	M6	6.0	1.0	6 - 7	0.6 - 0.7	4.3 - 5.1
	M8	8.0	1.25	14 - 18	1.4 - 1.8	10 - 13
			1.0	14 - 18	1.4 - 1.8	10 - 13
	M10	10.0	1.5	25 - 35	2.6 - 3.6	19 - 26
			1.25	26 - 36	2.7 - 3.7	20 - 27
	M12	12.0	1.75	45 - 61	4.6 - 6.2	33 - 45
1.25			50 - 68	5.1 - 6.9	37 - 50	
M14	14.0	1.5	76 - 103	7.7 - 10.5	56 - 76	
9T	M6	6.0	1.0	8 - 11	0.8 - 1.1	5.8 - 8.0
	M8	8.0	1.25	19 - 25	1.9 - 2.5	14 - 18
			1.0	20 - 27	2.0 - 2.8	14 - 20
	M10	10.0	1.5	36 - 50	3.7 - 5.1	27 - 37
			1.25	39 - 51	4.0 - 5.2	29 - 38
	M12	12.0	1.75	65 - 88	6.6 - 9.0	48 - 65
1.25			72 - 97	7.3 - 9.9	53 - 72	
M14	14.0	1.5	109 - 147	11.1 - 15.0	80 - 108	

1. Special parts are excluded.
2. This standard is applicable to bolts having the following marks embossed on the bolt head.

Grade	Mark
4T .....	4
7T .....	7
9T .....	9