

ENGINE FUEL & EMISSION CONTROL SYSTEM

SECTION EF & EC

CONTENTS

PRECAUTIONS FOR AN E.F.I. AND THE E.C.C.S. ENGINE	EF & EC- 3	BAROMETRIC PRESSURE SENSOR	EF & EC- 62
COMPONENT PARTS LOCATION FOR E.F.I. ENGINE	EF & EC- 4	EXHAUST GAS SENSOR	EF & EC- 63
COMPONENT PARTS LOCATION FOR E.C.C.S. ENGINE	EF & EC- 5	DETONATION SENSOR	EF & EC- 63
ENGINE AND EMISSION CONTROL SYSTEM DIAGRAM FOR E.F.I. ENGINE	EF & EC- 6	PARK/NEUTRAL SWITCH	EF & EC- 63
ENGINE AND EMISSION CONTROL SYSTEM CHART FOR E.F.I. ENGINE	EF & EC- 7	CAR SPEED SENSOR	EF & EC- 63
ENGINE AND EMISSION CONTROL SYSTEM DIAGRAM FOR E.C.C.S. ENGINE	EF & EC- 8	BATTERY VOLTAGE	EF & EC- 63
ENGINE AND EMISSION CONTROL SYSTEM CHART FOR E.C.C.S. ENGINE	EF & EC- 9	FUEL INJECTION CONTROL	EF & EC- 64
DIAGNOSTIC PROCEDURE FOR PROBLEMS	EF & EC- 10	FUEL PUMP CONTROL	EF & EC- 65
DIAGNOSIS	EF & EC- 10	ELECTRONIC IGNITION TIMING CONTROL	EF & EC- 67
DIAGNOSTIC PROCEDURE FOR E.F.I. ENGINE	EF & EC- 11	EXHAUST GAS RECIRCULATION (E.G.R.) CONTROL	EF & EC- 69
TROUBLE-SHOOTING CHART FOR E.C.C.S. ENGINE	EF & EC- 19	IDLE SPEED CONTROL	EF & EC- 70
E.C.C.S. ANALYZER INSPECTION	EF & EC- 20	AIR FLOW SYSTEM	EF & EC- 72
E.F.I. SYSTEM OPERATION	EF & EC- 49	AUXILIARY COOLING FAN	EF & EC- 77
FUEL INJECTION CONTROL	EF & EC- 49	DESCRIPTION	EF & EC- 77
SIGNALS FOR CONTROL UNIT	EF & EC- 49	OPERATION	EF & EC- 77
FUEL FLOW SYSTEM	EF & EC- 49	INSPECTION	EF & EC- 78
AIR FLOW SYSTEM	EF & EC- 54	ELECTRICAL SYSTEM INSPECTION	EF & EC- 80
ELECTRICAL SIGNAL SYSTEM	EF & EC- 55	E.F.I. CIRCUIT DIAGRAM	EF & EC- 80
FUEL SYSTEM PRESSURE CHECK	EF & EC- 58	DESCRIPTION	EF & EC- 81
ELECTRONIC CONCENTRATED ENGINE CONTROL SYSTEM (E.C.C.S.)	EF & EC- 61	PREPARATIONS FOR INSPECTION	EF & EC- 81
OUTLINE	EF & EC- 61	THROTTLE VALVE SWITCH TESTS	EF & EC- 82
E.C.C.S. CONTROL UNIT	EF & EC- 61	AIR FLOW METER TESTS	EF & EC- 84
CRANK ANGLE SENSOR	EF & EC- 61	AIR TEMPERATURE SENSOR TESTS	EF & EC- 86
THROTTLE VALVE SWITCH	EF & EC- 62	CYLINDER HEAD TEMPERATURE SENSOR TEST	EF & EC- 87
AIR FLOW METER	EF & EC- 62	EXHAUST GAS SENSOR CIRCUIT TEST	EF & EC- 87
CYLINDER HEAD TEMPERATURE SENSOR	EF & EC- 62	THERMOTIME SWITCH TESTS	EF & EC- 88
AIR TEMPERATURE SENSOR	EF & EC- 62	CONTROL UNIT GROUND CIRCUIT TESTS	EF & EC- 89
		AIR REGULATOR CIRCUIT TESTS	EF & EC- 90
		COLD START VALVE TEST	EF & EC- 91
		IGNITION COIL TRIGGER INPUT TEST	EF & EC- 91
		INJECTOR CIRCUIT TESTS	EF & EC- 92

E.F.I. RELAY AND FUEL PUMP	
RELAY TESTS	EF & EC- 94
IGNITION START SIGNAL TEST . . .	EF & EC- 95
E.C.C.S. CIRCUIT DIAGRAM	EF & EC- 96
DESCRIPTION	EF & EC- 97
PREPARATION FOR INSPECTION . . .	EF & EC- 97
THROTTLE VALVE SWITCH	
TESTS	EF & EC- 97
AIR FLOW METER TESTS	EF & EC- 98
AIR TEMPERATURE SENSOR	
TESTS	EF & EC-100
CYLINDER HEAD TEMPERATURE	
SENSOR TEST	EF & EC-101
EXHAUST GAS SENSOR CIRCUIT	
TEST	EF & EC-101
CONTROL UNIT GROUND CIRCUIT	
TESTS	EF & EC-102
AIR REGULATOR AND FUEL	
PUMP RELAY TESTS	EF & EC-103
INJECTOR CIRCUIT TESTS	EF & EC-105
E.F.I. RELAY	EF & EC-107
IGNITION START SIGNAL TEST . . .	EF & EC-107
VACUUM CONTROL MODULATOR	
(V.C.M.) TEST	EF & EC-108
PARK/NEUTRAL SWITCH	EF & EC-109
AIR CONDITIONER SWITCH	EF & EC-109

CRANKCASE EMISSION	
CONTROL SYSTEM	EF & EC-110
DESCRIPTION	EF & EC-110
INSPECTION	EF & EC-111

EXHAUST EMISSION CONTROL	
SYSTEM	EF & EC-112
EXHAUST GAS RECIRCULATION	
(E.G.R.) SYSTEM	EF & EC-112
SPARK TIMING CONTROL	
SYSTEM	EF & EC-113
BOOST CONTROLLED	
DECELERATION DEVICE	
(B.C.D.D.)	EF & EC-117
CATALYTIC CONVERTER	
SYSTEM	EF & EC-119

EVAPORATIVE EMISSION	
CONTROL SYSTEM	EF & EC-120
DESCRIPTION	EF & EC-120
OPERATION	EF & EC-121
INSPECTION	EF & EC-123

SERVICE DATA AND	
SPECIFICATIONS (S.D.S.)	EF & EC-125
GENERAL SPECIFICATIONS	EF & EC-125
INSPECTION AND ADJUSTMENT . . .	EF & EC-125
TIGHTENING TORQUE	EF & EC-126

PRECAUTIONS FOR AN E.F.I. AND THE E.C.C.S. ENGINE

Pay close attention to the following points when inspecting or servicing an E.F.I. or E.C.C.S. vehicle.

- Always use 12-volt batteries as power source.
- Do not attempt to disconnect battery cables while engine is operating.
- If a receiver-transmitter is installed, route antenna feeder cable along opposite side from E.F.I. or E.C.C.S. harness and control unit. Make sure that there is no interference while engine is idling.

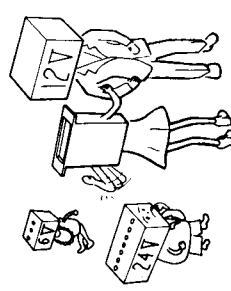

- Securely connect E.F.I. or E.C.C.S. harness connector. A poor connection can cause an extremely high (surge) voltage to develop in coil and condenser, thus resulting in damage to IC circuit.
- Keep E.F.I. or E.C.C.S. harness at least 10 cm (3.9 in) away from adjacent harnesses, to prevent an E.F.I. or an E.C.C.S. system malfunction due to reception of external noise, degraded operation of IC circuit, etc.
- Keep E.F.I. or E.C.C.S. parts and harnesses dry.
- Before removing parts, turn off ignition switch and then disconnect battery ground cable.

- Do not disassemble V.C.M. (For E.C.C.S. engine only.)

- Do not operate fuel pump when there is no fuel in lines.
- Do not use anti-freeze agents in fuel.
- Do not reuse fuel hose clamps.
- Tighten fuel hose clamps sufficiently.

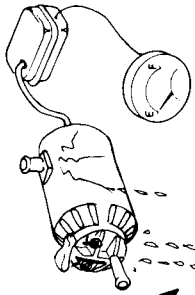

- Do not apply battery power directly to injectors.

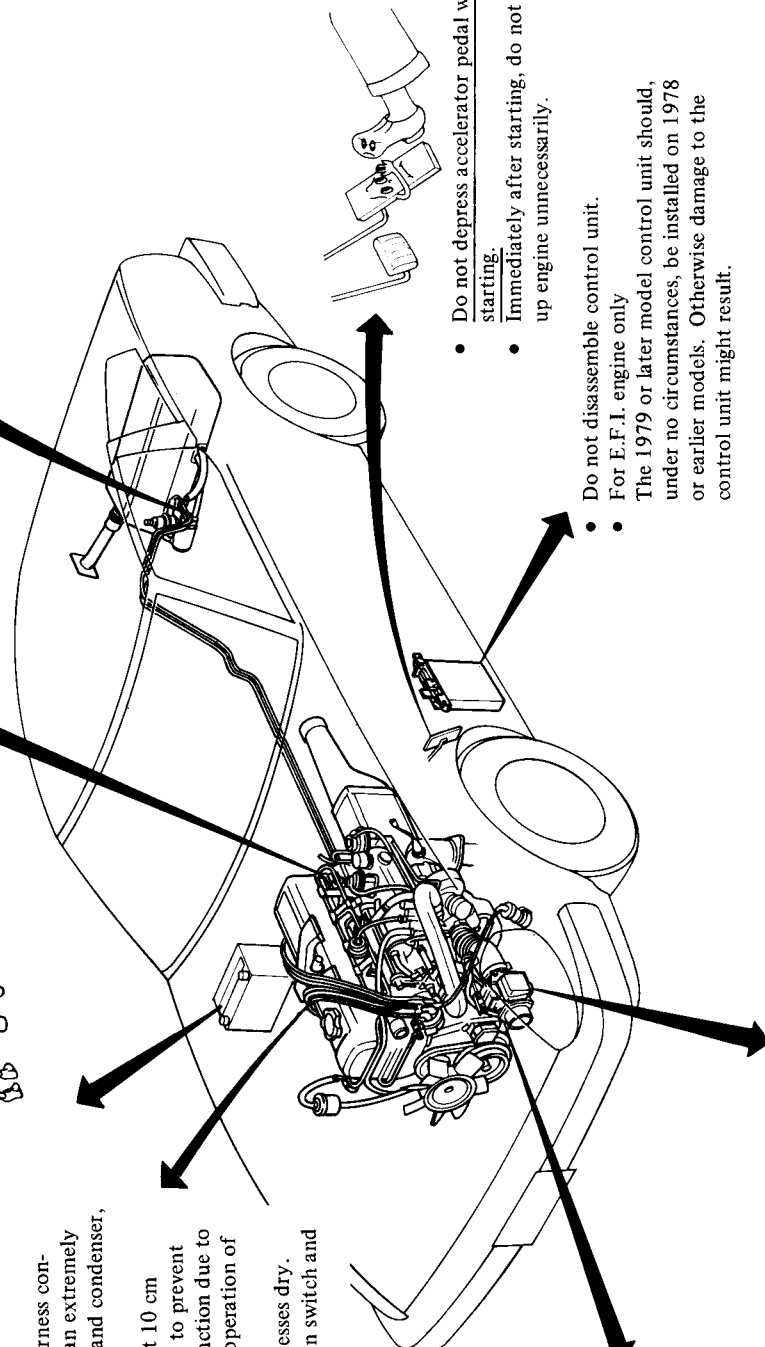

- Do not depress accelerator pedal when starting.
- Immediately after starting, do not rev up engine unnecessarily.

- Do not disassemble control unit.
- For E.F.I. engine only
The 1979 or later model control unit should, under no circumstances, be installed on 1978 or earlier models. Otherwise damage to the control unit might result.

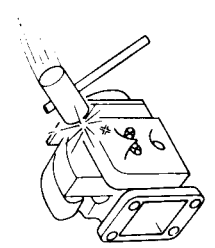

- Handle air flow meter carefully to avoid damage.
- There should not occur even a slight leak in air intake system.

COMPONENT PARTS LOCATION FOR E.F.I. ENGINE

Note: Mounting method may differ according to model.

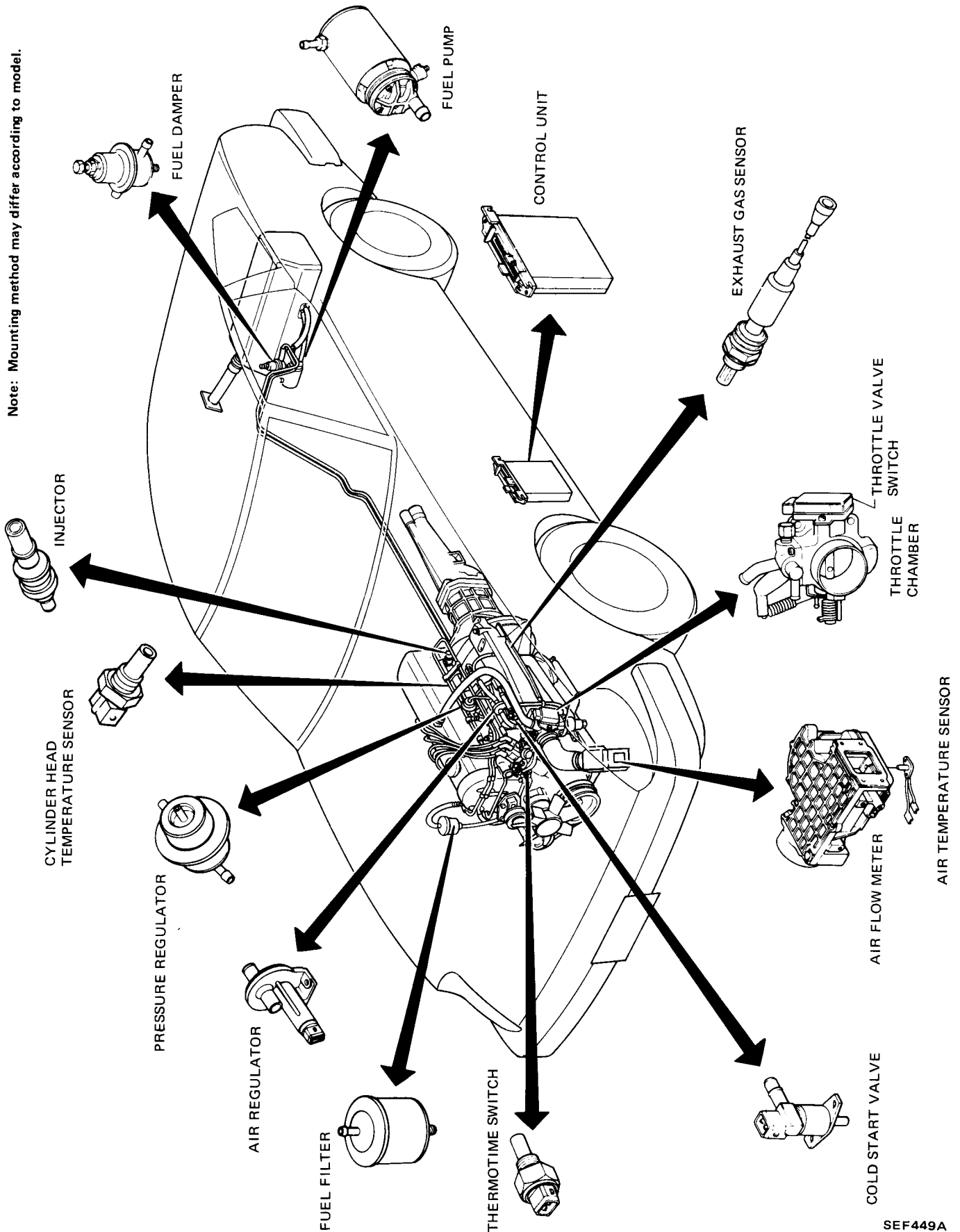

SEF449A

ENGINE AND EMISSION CONTROL SYSTEM DIAGRAM FOR E.F.I. ENGINE

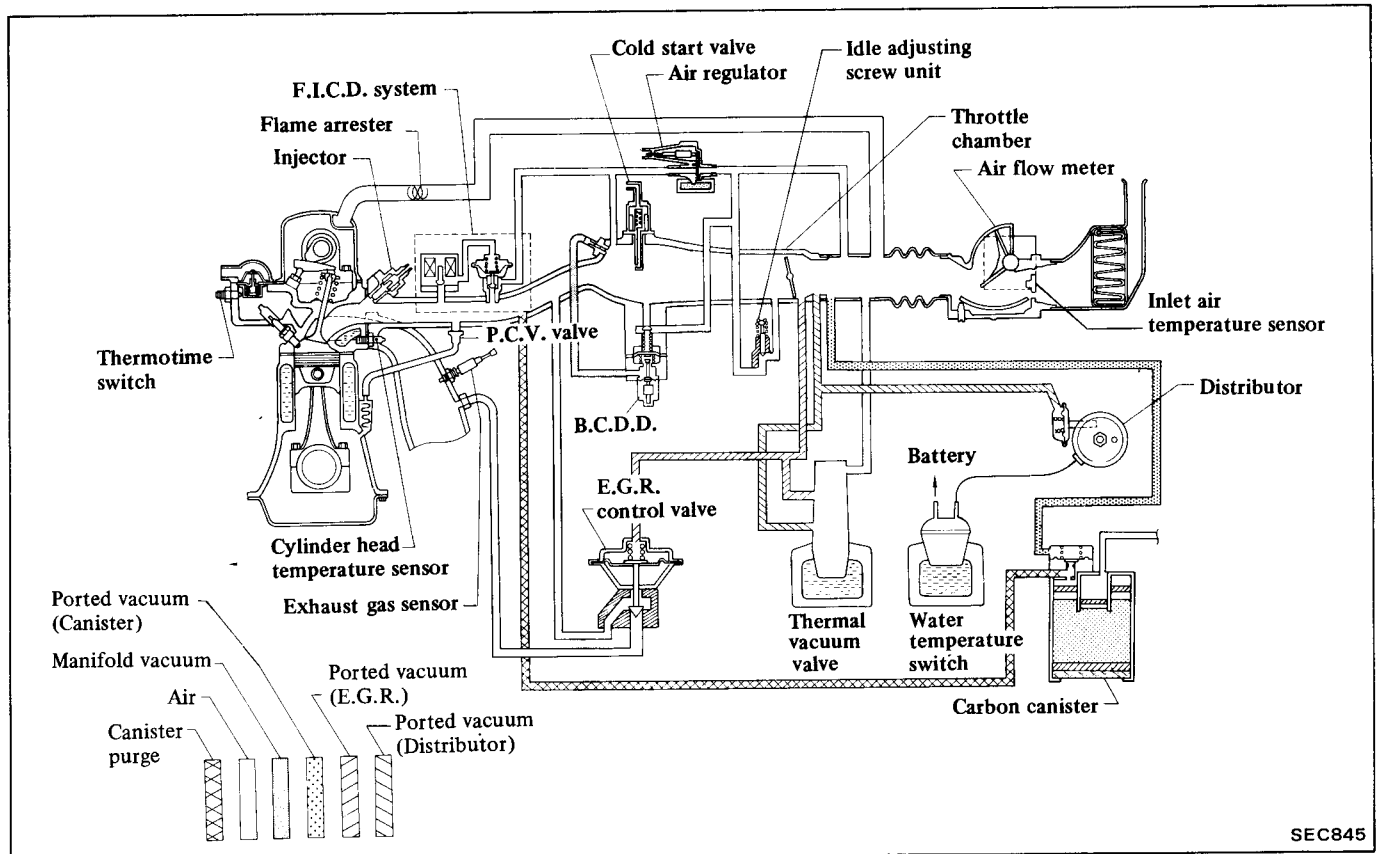
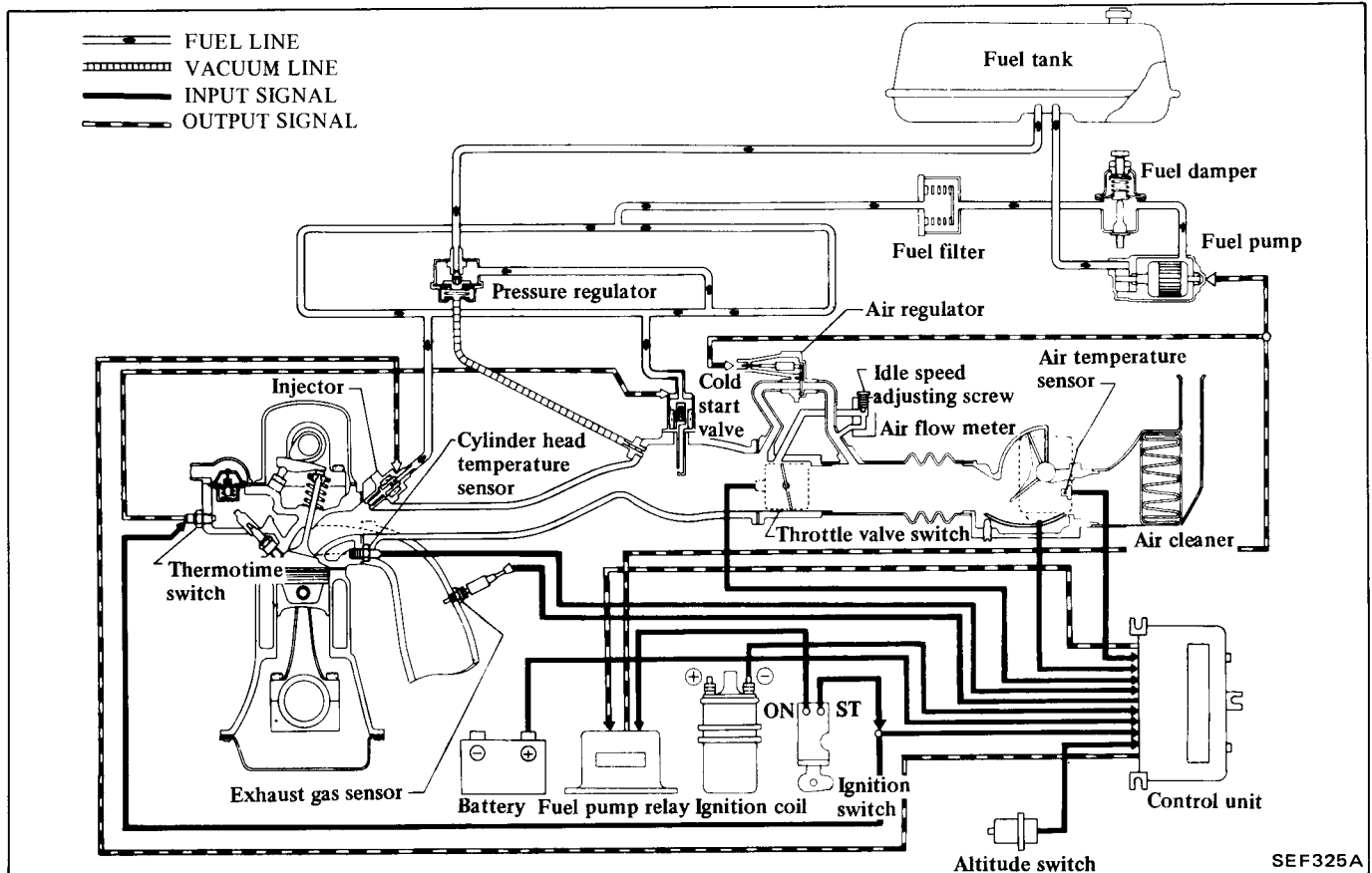

ENGINE AND EMISSION CONTROL SYSTEM CHART FOR E.F.I. ENGINE

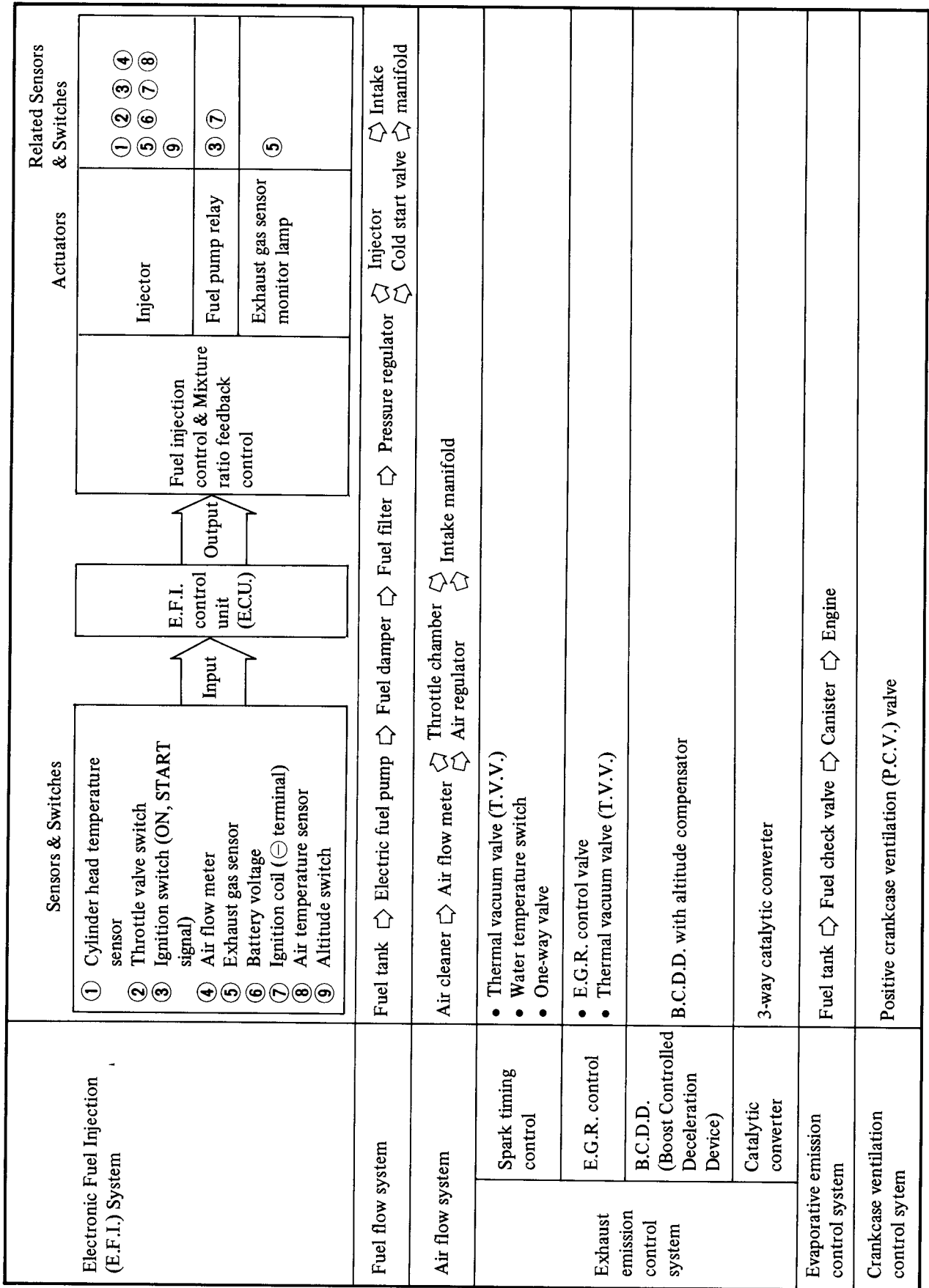

ENGINE AND EMISSION CONTROL SYSTEM DIAGRAM FOR E.C.C.S. ENGINE

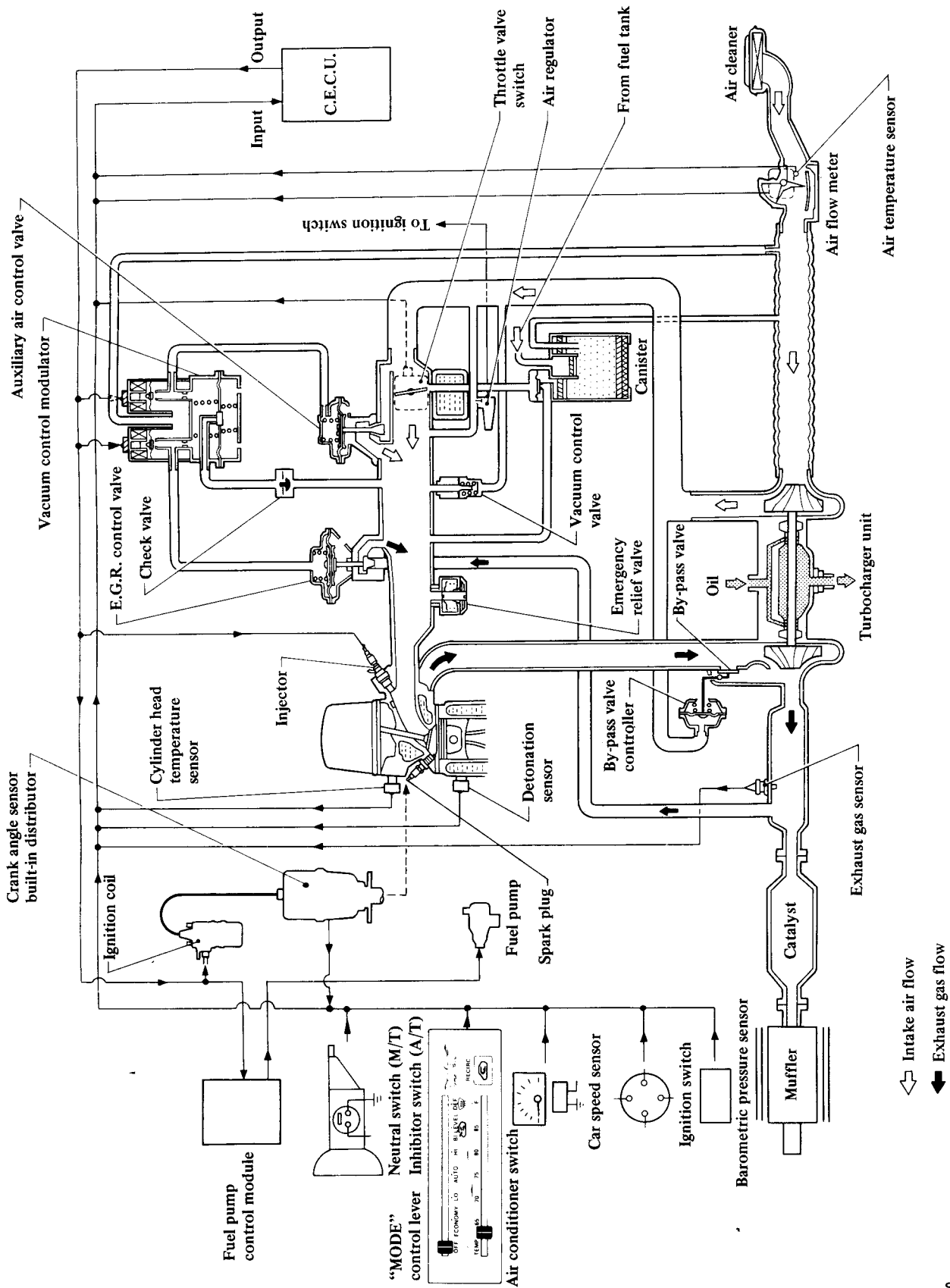

ENGINE AND EMISSION CONTROL SYSTEM CHART FOR E.C.C.S. ENGINE

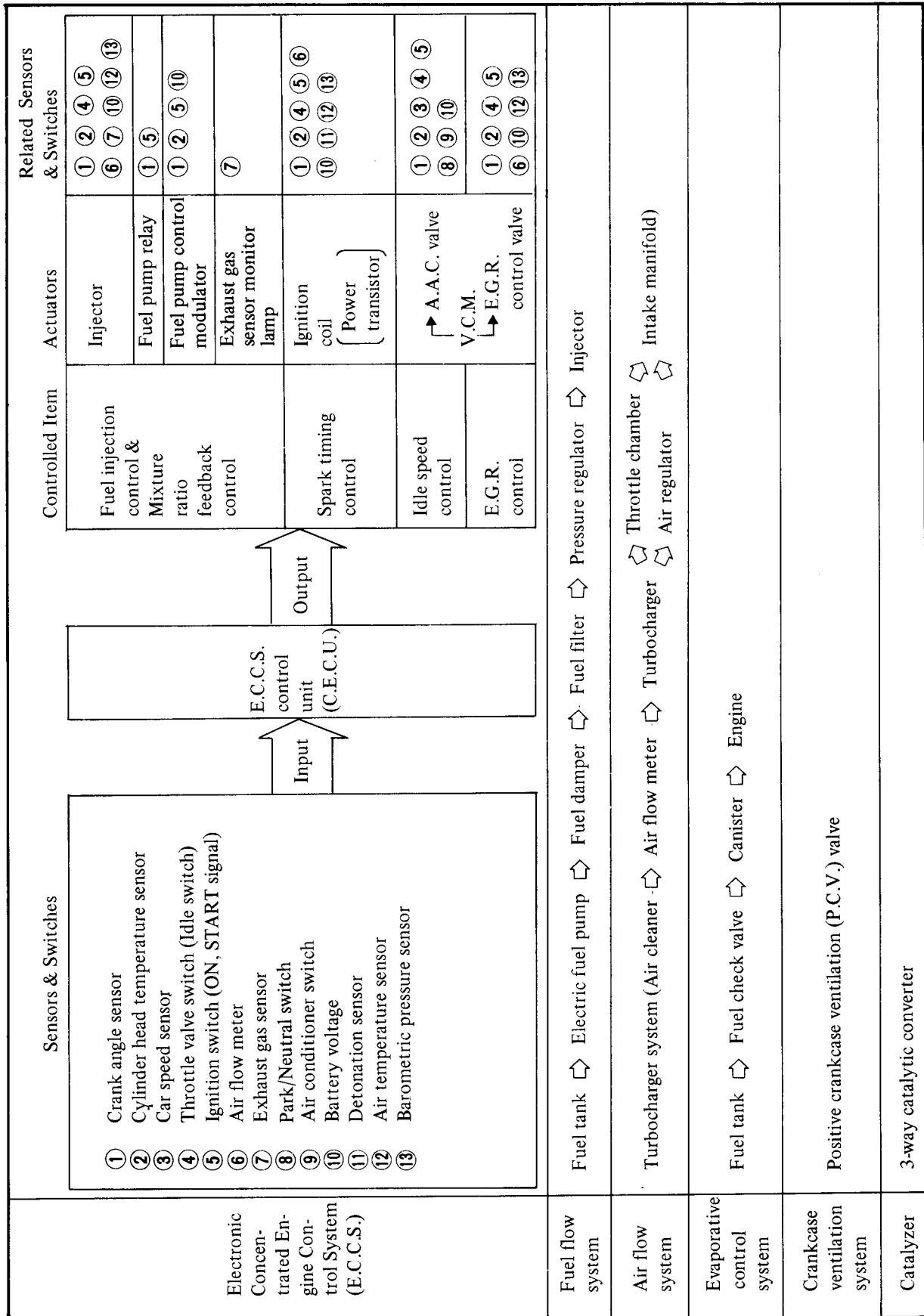

DIAGNOSTIC PROCEDURE FOR PROBLEMS

DIAGNOSIS

INTERMITTENT PROBLEM

DIAGNOSTIC CHARTS CANNOT BE USED TO DIAGNOSE INTERMITTENT FAILURES. This is because many intermittent problems are caused at electrical connections, and if intermittent problems are not corrected, unnecessary component replace-

ment will be indicated and the problems may remain. Therefore, DIAGNOSIS OF INTERMITTENT PROBLEMS SHOULD START WITH A VISUAL AND PHYSICAL INSPECTION OF THE CONNECTORS involved in the circuit, especially control unit, air flow meter, cylinder head temperature sensor and exhaust gas sensor connectors.

CAUTION:

When connecting or disconnecting E.F.I. or E.C.C.S. harness connector to or from any E.F.I. or E.C.C.S. unit, ensure that the ignition switch is in the "OFF" position and that the negative battery terminal is disconnected. Removing and installing these connectors with the ignition switch left in the "ON" position will damage control unit.

DIAGNOSTIC PROCEDURE FOR E.F.I. ENGINE

DRIVEABILITY

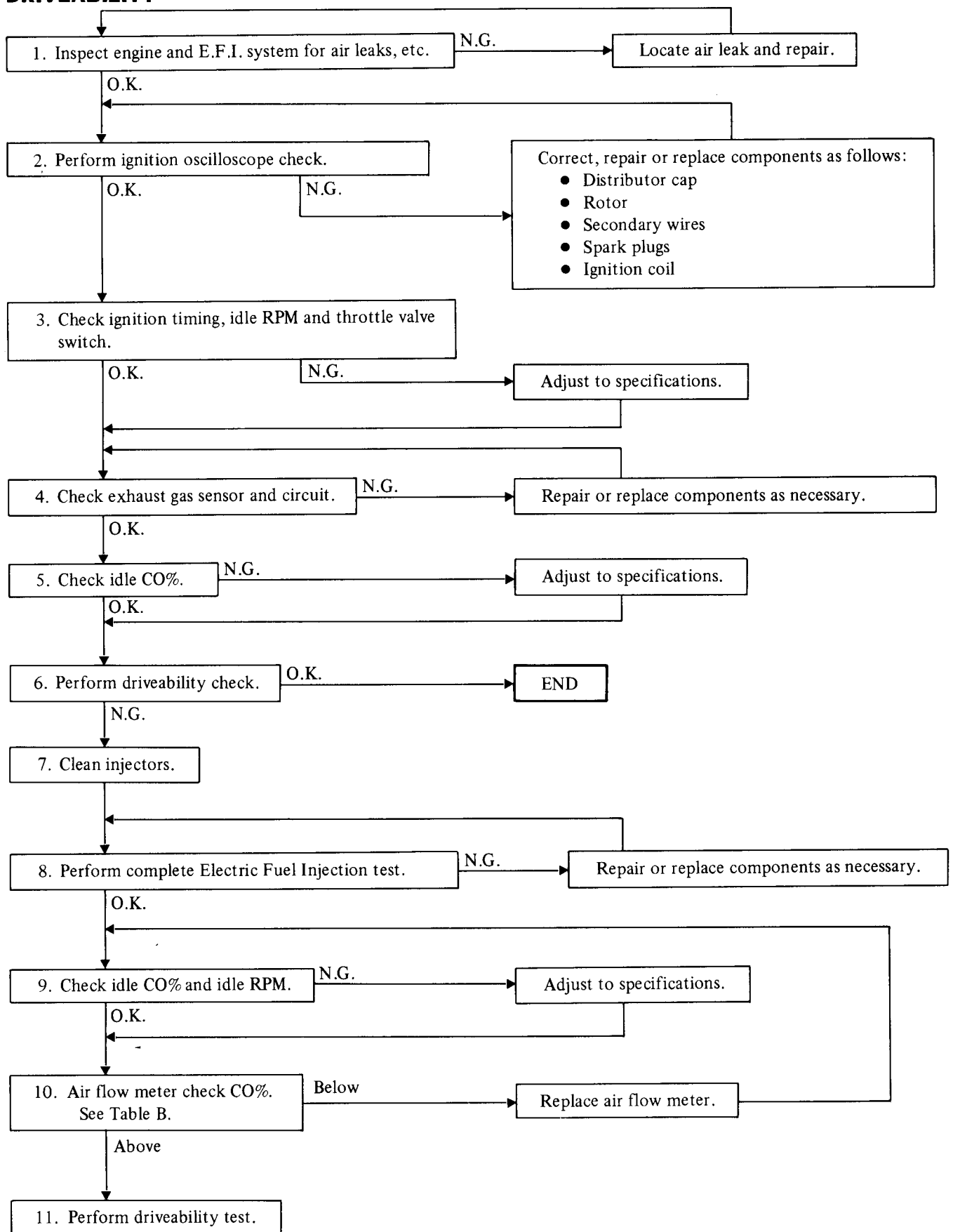

IMPROPER IDLING

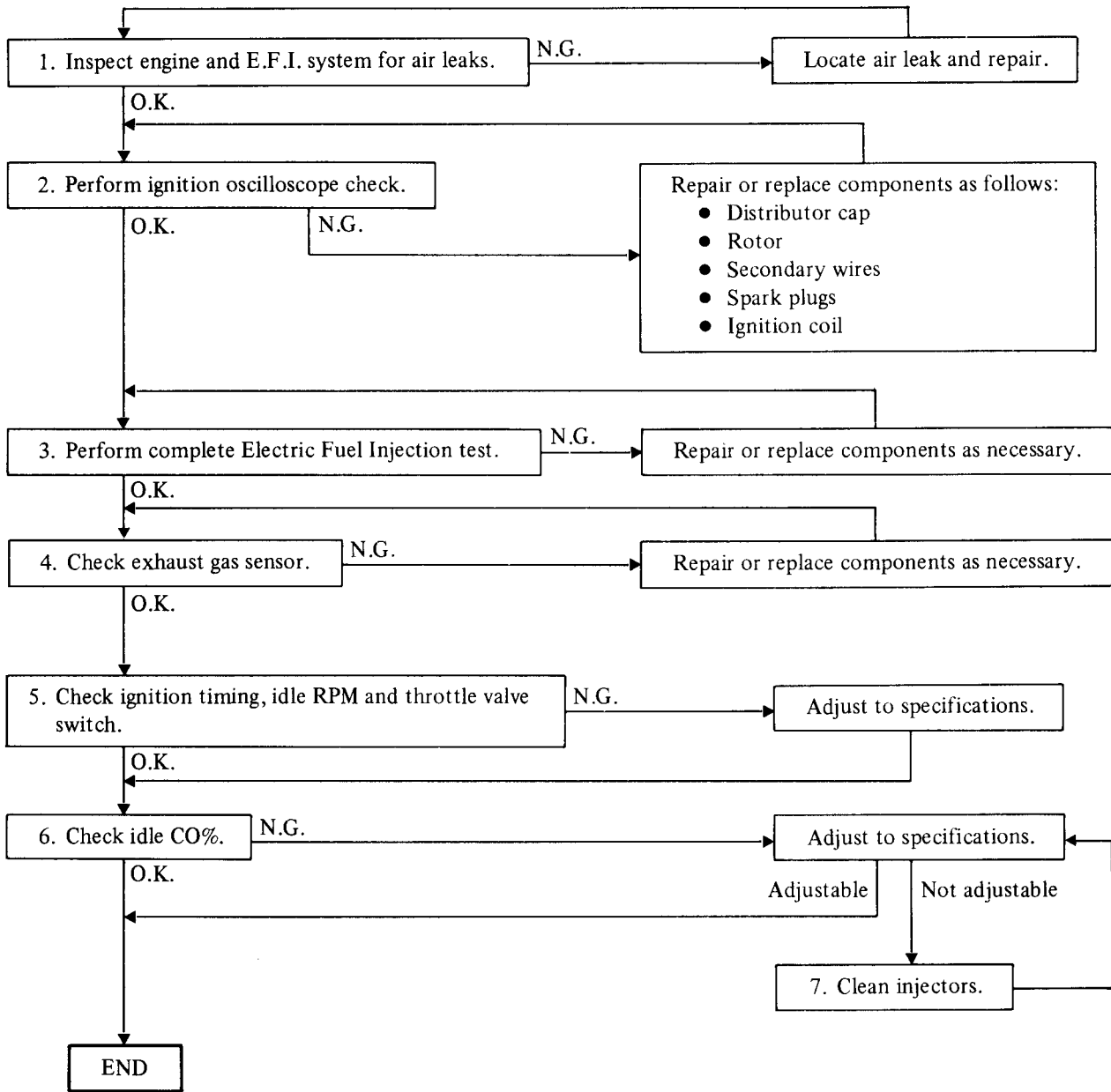

ENGINE STARTABILITY

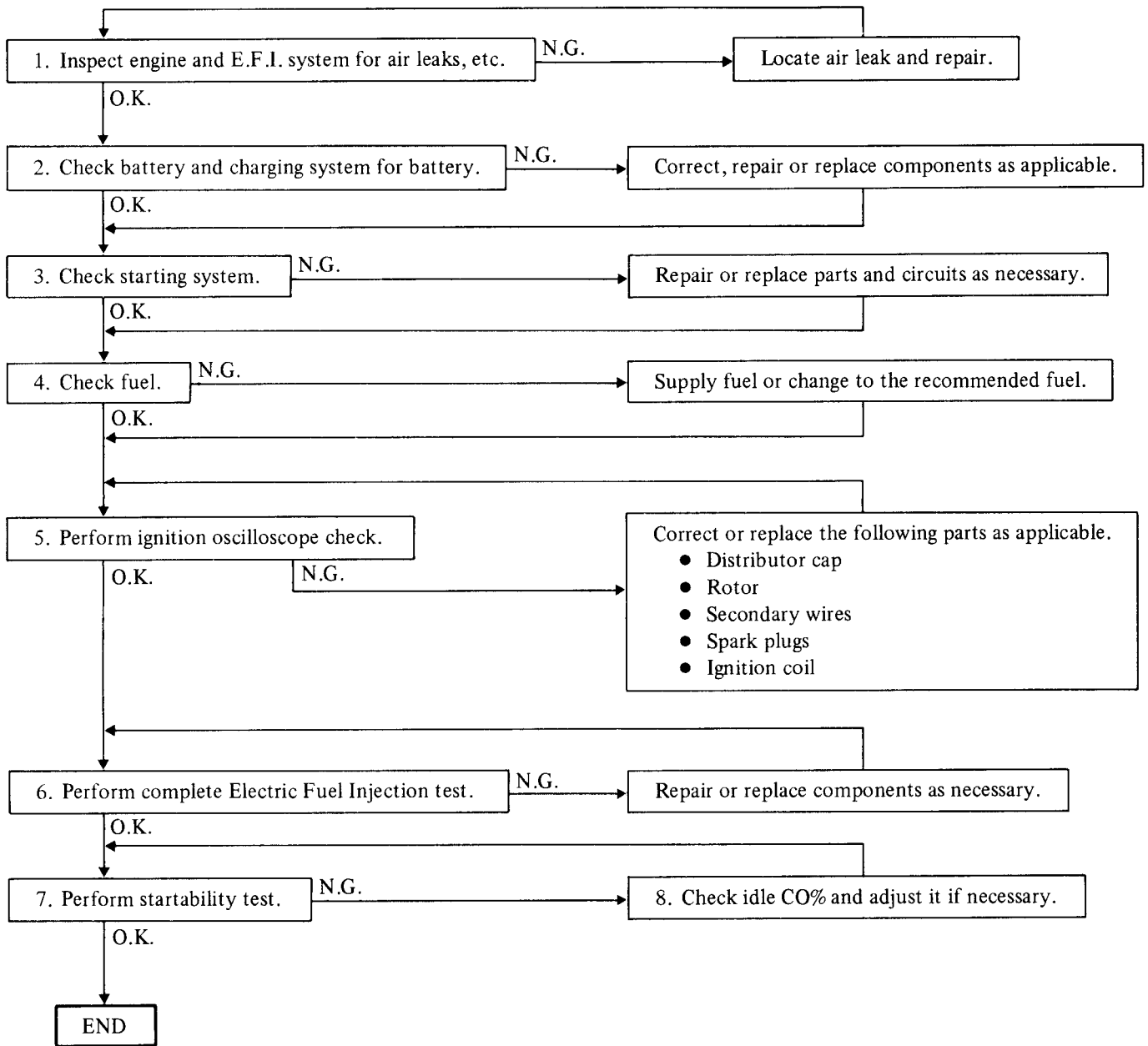

ENGINE STALL

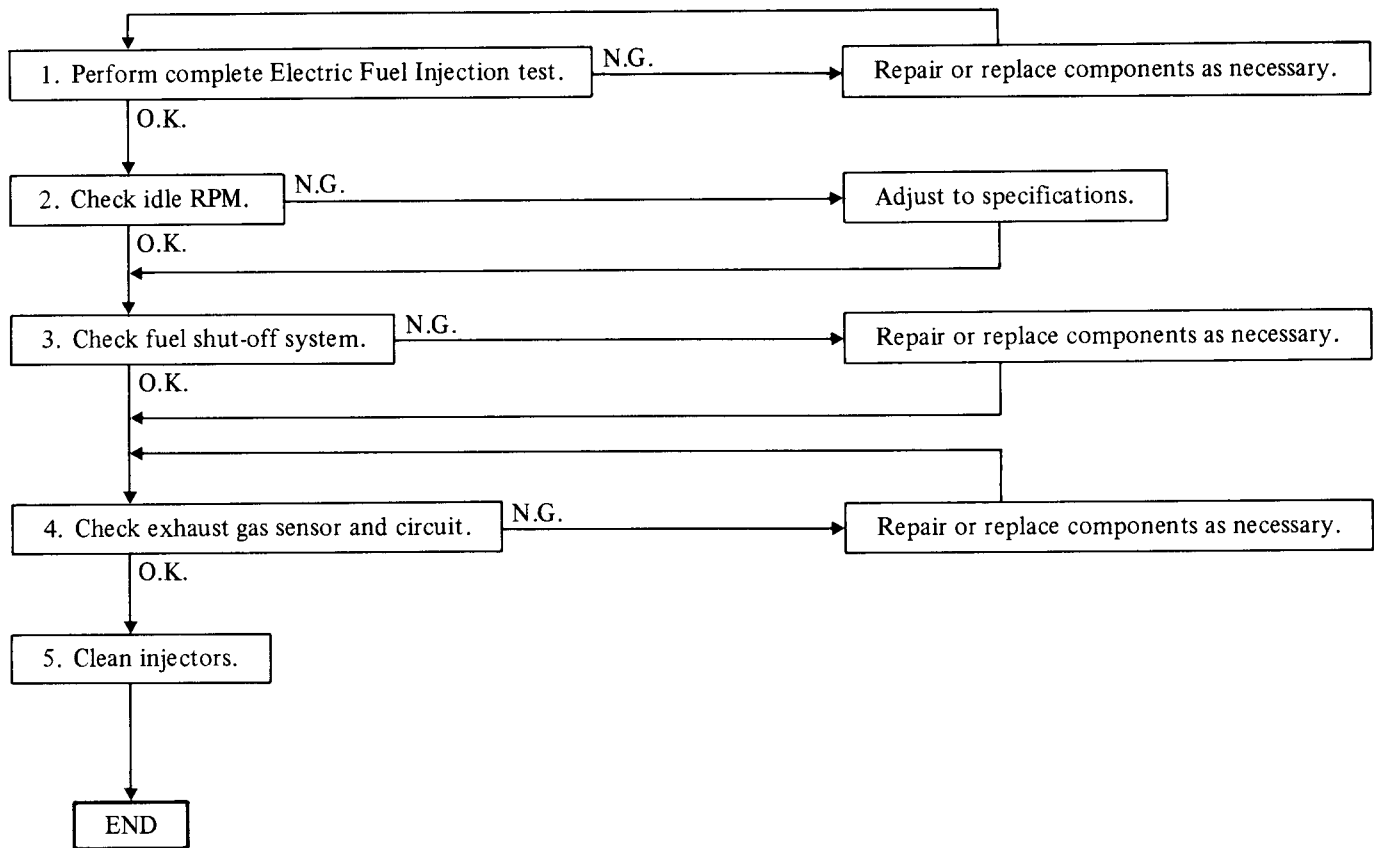

DIAGNOSTIC STEPS FOR DRIVEABILITY

1. Inspect engine and E.F.I. system for leaks.

- (1) Check clamps at all air intake components.
- (2) Check vacuum hoses for leakage.
- (3) Check air cleaner filter for clogging.
- (4) Visually inspect for leaks at the following:

- Dipstick
 - Intake manifold gasket
 - Valve rocker cover
 - E.G.R. valve gasket
 - Oil filler cap
 - Air intake hoses and duct
- (5) Check E.G.R. valve seat and operation.

(6) Check air regulator operation.

2. Perform ignition oscilloscope test.

- (1) Warm engine to operating temperature.
- (2) Check ignition system for unusually high or low firing voltage.
- (3) If firing voltage is abnormal, determine cause and repair.

3. Check ignition timing, idle rpm and throttle valve switch.

(1) Checking and adjusting ignition timing.

- Checks and adjustments are made with the air conditioning compressor "OFF".**
- a) Verify that the engine is still at operating temperature.
- b) Rev the engine to 4,000 rpm two or three times under no-load, then allow it to run at idle speed for one minute.
- c) Check idle speed

M/T:
700±100 rpm
A/T:
700±100 (in "D" position)

If necessary, adjust to the specified rpm by turning the idle speed adjusting screw.

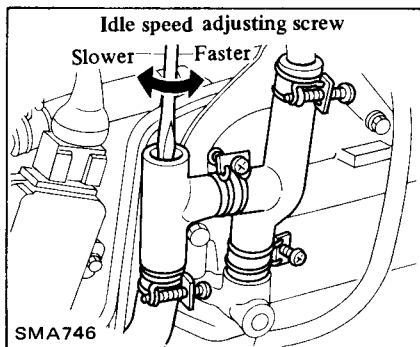

- d) Disconnect distributor vacuum hose from distributor vacuum controller, and plug hose with proper plug. Then, check ignition timing with a timing light.

8°±2° B.T.D.C.

Adjust as necessary.

(2) Check throttle valve switch adjustment.

- a) Disconnect the throttle valve switch harness connector from the throttle switch body.
- b) Connect an ohmmeter between terminals 29 and 30, make sure continuity exists.
- c) Increase engine speed. The ohmmeter should show continuity until 900 rpm ±20 rpm, and at that point the circuit should break and cause the ohmmeter to indicate an open circuit. If incorrect, adjust as follows:

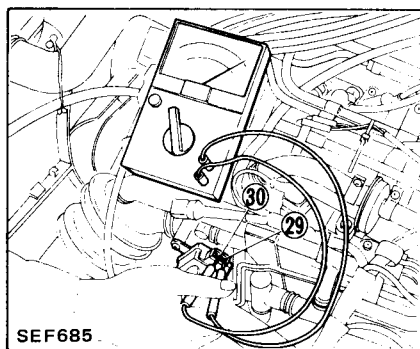

- 1) Hold engine speed at 900 rpm by manually opening the throttle.

Important: Do not use the idle speed screw.

- 2) Loosen the throttle switch mounting screws and turn the switch body until the ohmmeter shows a closed circuit.

- 3) Slowly rotate the switch counterclockwise until the ohmmeter indicates an open circuit; at that exact point, tighten the mounting screws.
- 4) Recheck the adjustment.
- 5) Reset idle speed if necessary.

4. Check exhaust gas sensor. (Refer to page 42).

- (1) Verify that the engine is still at operating temperature.
- (2) Run engine at about 2,000 rpm for about 2 minutes under no-load.
- (3) Make sure that inspection lamp on control unit goes on and off more than 5 times during 10 seconds. If not, perform the following test.
- (4) Check exhaust gas sensor harness.
 - a) Turn off engine and disconnect battery ground cable.
 - b) Disconnect E.F.I. 35-pin connector from control unit.
 - c) Disconnect exhaust gas sensor harness connector and connect terminal for exhaust gas sensor to ground with a jumper wire.

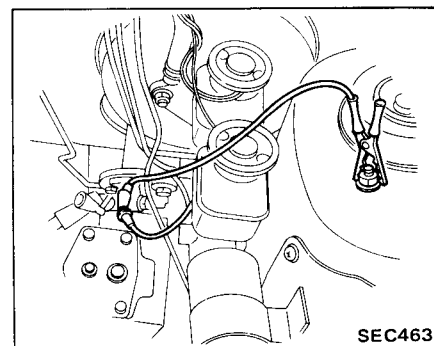

- d) Check for continuity between terminal NO. 31 of E.F.I. 35-pin connector and ground metal on car body.

Continuity exists O.K.
Continuity does not exist . . . N.G.

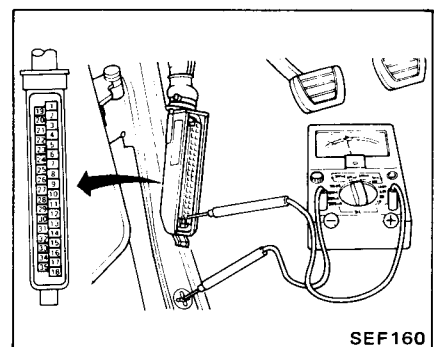

If N.G., correct or replace E.F.I. harness.

(5) Check E.F.I. control unit.
Start engine and check inspection

lamp on control unit for the following conditions.

Harness connector of exhaust gas sensor	Inspection lamp
① Disconnected	Does not glow
② Grounded	Glow

If O.K., replace exhaust gas sensor.
If N.G., replace control unit.

5. Check idle CO%.

The checking or adjustment of idle CO% requires the use of a CO meter. It is essential that the meter be fully warmed up and calibrated before any adjustment is made.

- (1) Verify that the engine is at operating temperature.
- (2) With the hood open, run the engine at 2,000 rpm for 2 minutes at no-load, to stabilize its condition.
- (3) Turn the ignition switch to the "OFF" position.
- (4) Disconnect the throttle valve switch harness connector.
- (5) Connect a lead wire, as shown between terminals No. 24 and No. 30 of the throttle valve harness connector.

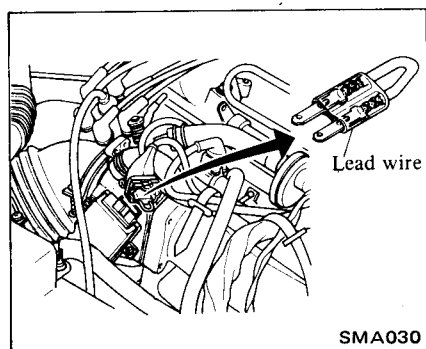

- (6) Disconnect exhaust gas sensor harness connector.
- (7) Rev. the engine to 4,000 rpm 2 or 3 times under no-load, finally, allow it to run at idle speed for one minute.
- (8) Reset idle speed to the specified speed.
- (9) Check CO% at the applicable altitude as per Table A, Column 1 and

if necessary, adjust to the specified point at the applicable altitude as per Table A, Column 2. The CO% adjustment is made by turning the air bypass screw on the air-flow meter. (Refer to EC section.)

On models equipped with altitude switch, disconnect altitude switch connector before checking idle CO%.

Table A

Altitude m (ft)	Check idle CO% (full enrichment) Column 1	Adjust idle CO% (full enrichment) Column 2	Check idle CO% (W/O full enrichment) Column 3
0 - 600 (0 - 2,000)	0.2 - 5.0	1.0	2.7 or lower
600 - 1,200 (2,000 - 4,000)	1.5 - 6.4	2.4	4.1 or lower
1,200 - 1,800 (4,000 - 6,000)	2.5 - 7.3	3.5	0.2 - 5.0
Above 1,800 (6,000)	3.5 - 8.3	4.7	1.2 - 6.0

- (10) Stop engine, remove the lead wire and reconnect the throttle valve switch harness to the throttle valve switch.

- (11) Check the idle speed. Readjust to the specified speed.
- (12) Recheck to verify that CO% is still within specifications (See Table A, Column 3).

After rechecking CO%, reconnect exhaust gas sensor harness connector.

6. Perform driveability test.
 - (1) Evaluate effectiveness of adjustments by driving vehicle.
 - (2) If unsatisfactory, proceed to step 7.
7. Clean injectors.
8. Perform complete Electronic Fuel Injection Test.
 - (1) Use the Kent-Moore J-25400 E.F.I. Analyzer and J-25400-36 Adapter.
 - (2) Follow procedure in the Datsun Electronic Fuel Injection Manual, beginning on page 101.
 - (3) Repair system as necessary.
9. Check idle CO% and idle rpm.
 - (1) Follow the procedure from step 4, operations (1) through (9).
 - (2) Proceed to step 10.
10. Air flow meter check – confirm engine temperature – warm up if necessary.
 - (1) Check idle CO% and idle rpm. Follow procedure in step 5.
 - (2) Raise engine speed to 2,000 rpm under no-load and check CO% as per Table B.

Table B

Altitude m (ft)	Minimum CO%
0 - 600 (0 - 2,000)	0.8
600 - 1,200 (2,000 - 4,000)	2.3
1,200 - 1,800 (4,000 - 6,000)	3.4
Above 1,800 (6,000)	4.4

- (3) If CO% is above the specified point, go to operation.
- (4) If CO% is below the specified point, replace the air flow meter and adjust idle CO% and rpm per step 5.

- (5) Stop engine, remove the lead wire and reconnect the throttle valve switch harness to the throttle valve switch.
- (6) Recheck the idle speed, adjust to the specified speed.
- (7) Recheck to verify that CO% is still within specifications (see Table A, Column 3).

After rechecking CO%, reconnect exhaust gas sensor harness connector.

11. Perform driveability test.
 - Re-evaluate vehicle performance.

DIAGNOSTIC STEPS FOR IMPROPER IDLING

1. Inspect engine and E.F.I. system for leaks.
2. Perform ignition oscilloscope test.
3. Perform complete Electric Fuel Injection Test.
4. Check exhaust gas sensor.
5. Check ignition timing, idle rpm and throttle valve switch.
6. Check idle CO%.
7. Clean injectors.

Refer to **DIAGNOSTIC STEPS FOR DRIVEABILITY** on the inspection procedure of each item.

ENGINE STARTABILITY

1. Inspect engine and E.F.I. system for leaks.
 - Refer to **DIAGNOSTIC STEPS FOR DRIVEABILITY**.
2. Check battery and charging system for battery.
 - (1) Check battery voltage.
 - (2) If poor battery voltage, check charging system for battery.
 - Alternator
 - Voltage regulator
 - Others
 Refer to EL section.

3. Check starting system.
 - (1) Check starter operation.
 - (2) If it does not operate, check the following:
 - Starter
 - Ignition relay
 - Ignition switch
 - Others
 Refer to EL section.
4. Check fuel.
 - (1) Check fuel level.
 - If low or empty, add fuel.
 - (2) Check fuel octane rating.
 - If not proper, change to the recommended gasoline.
5. Perform ignition oscilloscope test.
 - Refer to **DIAGNOSTIC STEPS FOR DRIVEABILITY**.
6. Perform complete Electric Fuel Injection test.
 - Refer to **DIAGNOSTIC STEPS FOR DRIVEABILITY**.
7. Perform startability test.
 - (1) Start engine with the recommended starting procedure.
 - (2) If engine does not start, proceed to step 8.
8. Check and adjust idle CO%.
 - Check idle CO%. Follow the procedure from step 5, operations (1) through (9) in **DIAGNOSTIC STEP FOR DRIVEABILITY**.

ENGINE STALL

1. Perform complete Electric Fuel Injection test.
 - Refer to **DIAGNOSTIC STEPS FOR DRIVEABILITY**.
2. Check idle rpm.
 - Check idle rpm. Follow the procedure from step 3-(1), operations a) through c) in **DIAGNOSTIC STEP FOR DRIVEABILITY**.
3. Check fuel shut-off system.
 - (1) Check engine speed signal (ignition coil-trigger input transmitted to E.C.U. from ignition coil.

(2) Check cylinder head temperature sensor.

- Check circuits and system with the Kent-Moore J-25400 E.F.I. Analyzer and J-25400-36 Adapters. (Refer to DIAGNOSTIC STEPS FOR DRIVEABILITY.)
- Check component as follows:

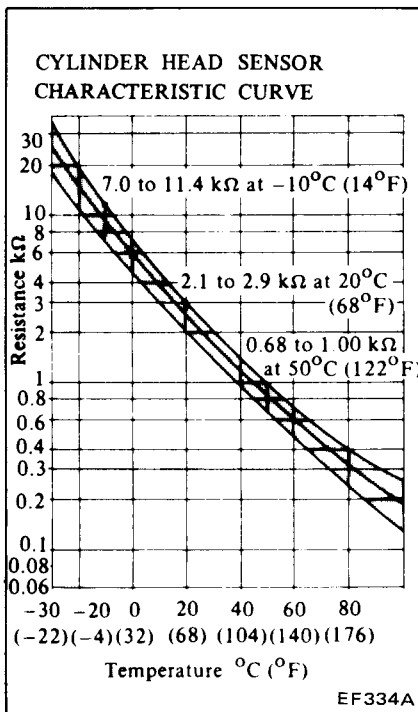
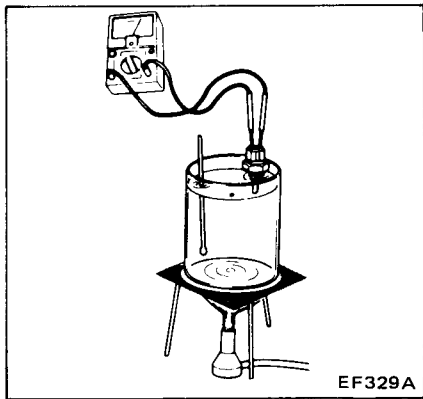

4. Check exhaust gas sensor and circuit.

Refer to DIAGNOSTIC STEPS FOR DRIVEABILITY.

5. Clean injectors.

TROUBLE-SHOOTING CHART FOR E.C.C.S. ENGINE

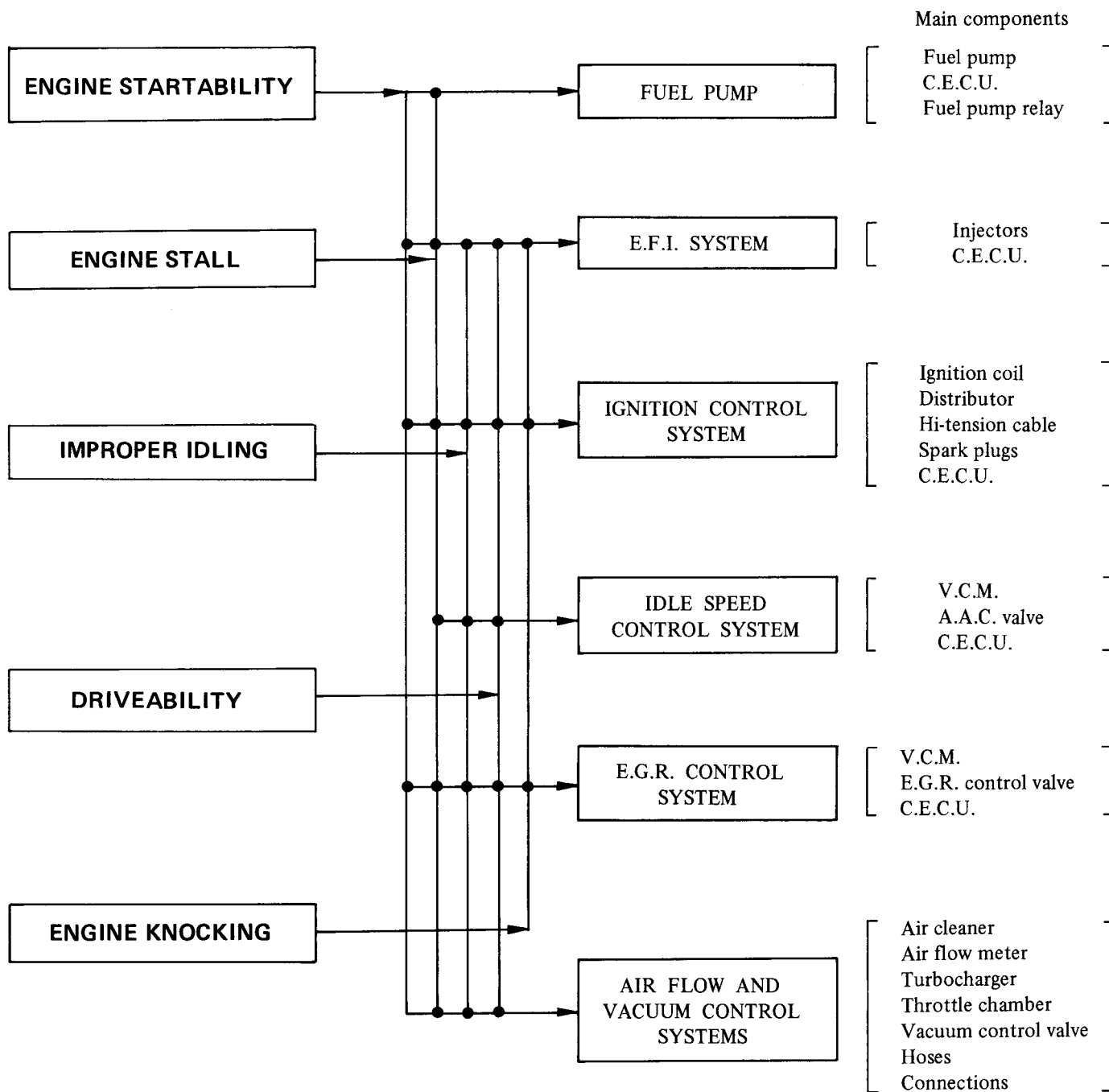

Use the above chart to easily determine in what portion the malfunction is taking place, what is malfunctioning, what to check and how to cope with the problems.

Then, use E.C.C.S. analyzer when checking each component and other parts of E.C.C.S. using the above chart.

E.C.C.S. ANALYZER INSPECTION

Electronic Concentrated engine Control System (E.C.C.S.) controls the engine operating conditions (Fuel injection, Idle rpm, Ignition timing, E.G.R., etc.) with the Central Electronic Control Unit (C.E.C.U.), Sensors, Switches and so forth.

Therefore, when engine malfunctions occur, the causes cannot be found by a visual inspection, etc. Then, use an E.C.C.S. analyzer to diagnose of the problem.

E.C.C.S. ANALYZER (J-28835)

The E.C.C.S. analyzer monitors

several input and output signals that are emitted in response to various engine operating conditions and when the engine stops. Input signals are compared to computerized signal values stored in the C.E.C.U. (Central Electronic Control Unit) while output signals are monitored to ensure they are properly attuned before they are emitted from the C.E.C.U. unit to actuators. In other words, this analyzer analyzes all electrical signals that are transmitted to and emitted from the C.E.C.U. unit. For this reason, if system or unit abnormalities which are not related to these signals are discovered, reference to the "Trouble-shooting" chart must be made for remedial action.

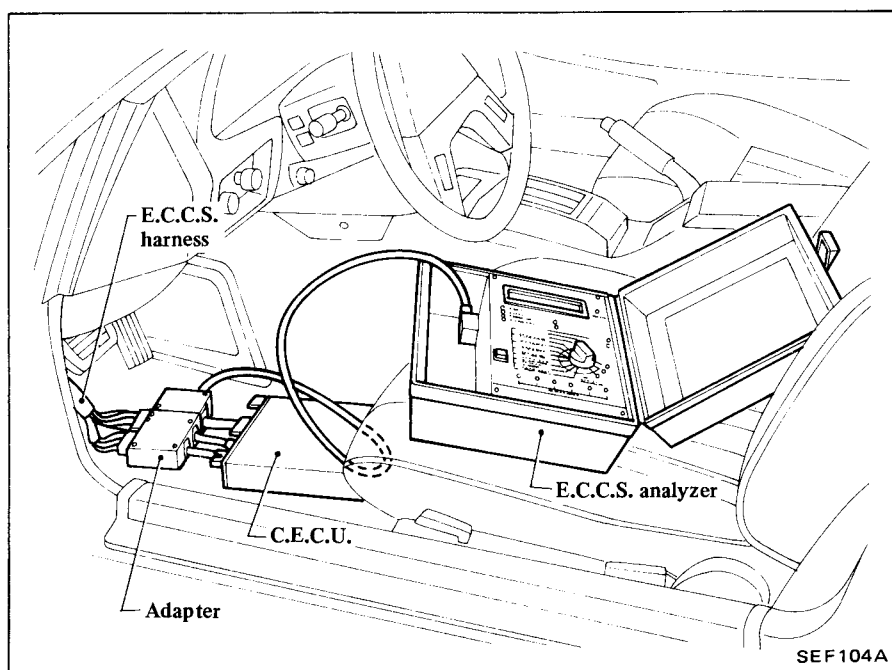

Operation

1. Make sure ignition switch is "OFF".
2. Remove C.E.C.U. unit and connect both adapter and analyzer.

CAUTION:

Make sure parking brake has been applied and selector lever is in "Neutral" (M/T) or in "P" or "N" (A/T).

3. Turn ignition switch "ON", and check the following:

(1) Switches

- Idle switch (Throttle valve switch)
Check idle switch while depressing and releasing accelerator pedal repeatedly.
- Neutral switch (Transmission switch)
Check neutral switch while repeatedly shifting selector lever to "Neutral" or "N" (or: "P") from other positions.

- Air conditioner switch
Check air conditioner switch by turning/moving it on and off repeatedly.
- Starter switch
Turn ignition switch to "START". In these cases, make sure each monitor lamp illuminates.

(2) Actuators and sensors

Use rotary switch to check.

During the following checks, turn rotary switch to the next position after the previous check.

- IGN. (Ignition system)
Depress CHECK button and make sure monitor lamp illuminates.

After checking ignition system, be sure to return ignition switch from "ON" to "ACC" or "OFF".

- Fuel pump
Before checking, return ignition switch to "ON".
Depress CHECK button and make sure monitor lamp turns on and off alternately. Also check fuel pump relay's operating sound when monitor lamp illuminates.

Fuel pump always operates for five seconds after ignition switch has been turned to "ON".

- E.G.R.
Depress CHECK button and make sure monitor lamp brightens and dims alternately. At this point, make sure V.C.M. solenoid valve is functioning properly.
- Idle speed control
Follow same procedure used for E.G.R. checks above.
- Battery and air flow meter
Depress CHECK button and make sure O.K. monitor lamp illuminates.

(3) Turn rotary switch to “E.G.R.” position. Start engine, warm it up sufficiently, and then check the following:

When turning rotary switch for the following checks, accelerator pedal may be depressed slightly to avoid engine stall.

- E.G.R.
Slightly depress accelerator pedal before CHECK button is depressed. Monitor lamp should brighten and dim alternately and engine speed should vary.
- Idle speed control
Follow same procedure used for E.G.R. checks above.
- Battery
Depress CHECK button and make sure O.K. monitor lamp illuminates.
- Air flow meter
Depress CHECK button, then gradually increase engine speed. In this case, O.K. monitor lamp should illuminate and then go out. Also make sure that O.K. monitor lamp illuminates and goes out as engine speed decreases.
- Air temperature, altitude and cylinder head temperature sensors

Depress CHECK button and make sure O.K. monitor lamp illuminates.

- Knocking sensor
Depress CHECK button and then depress accelerator pedal forcibly so engine knocks. In this case, O.K. monitor lamp should illuminate. If engine does not knock, repeat above procedure until it does.

CAUTION:

Be sure parking brake has been applied firmly before conducting above tests.

- Crank angle sensor
Depress CHECK button, and gradually increase engine speed. When engine speed reaches approximately 1,800 rpm, O.K. monitor lamp will illuminate; when engine speed reaches approximately 2,200 rpm, O.K. monitor lamp will extinguish. O.K. monitor lamp will remain off while engine speed exceeds approximately 2,200 rpm. Decreasing engine speed will cause O.K. monitor lamp to activate completely differently from the above sequence.
- Car speed sensor
Conduct this test by one of the

following two methods:

- a. Raise the rear wheels clear of the floor. Block front wheels securely. Use floor stands to support the side member.
 - b. Chassis dynamometer test.
Depress CHECK button and increase vehicle speed. As vehicle speed reaches approximately 10 km/h (6 MPH), O.K. monitor lamp will illuminate. The lamp will extinguish when car speed reaches approximately 30 km/h (19 MPH).
- C.A.S. (Crank angle sensor)
O.K. monitor lamp remains on as long as the crank angle sensor emits a signal (engine continues to run).
 - E.F.I. and injectors
When fuel is being supplied (engine is operating), E.F.I. monitor lamp brightens and dims alternately and all injector monitor lamps are “ON”. If an injector monitor lamp fails to illuminate, it means that particular injector is malfunctioning. These monitor lamps are also used to check the fuel shut-off system operating condition.

Inspection

While engine is not running:

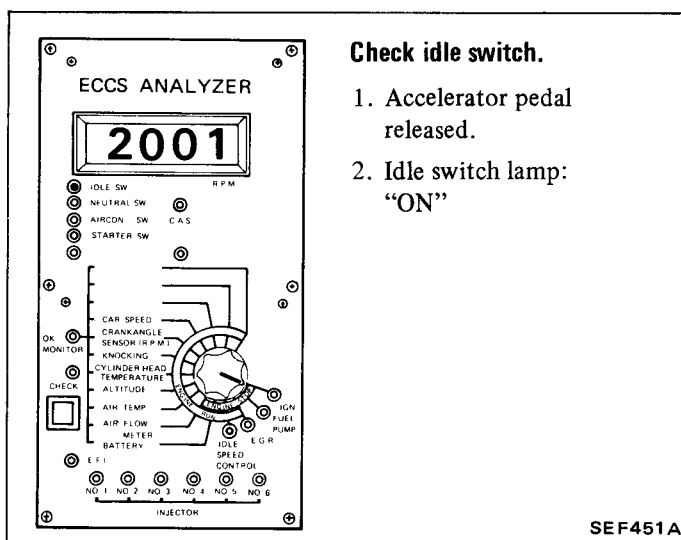

Check idle switch.

1. Accelerator pedal released.
2. Idle switch lamp: “ON”

O.K.

Ⓐ

N.G.

Ⓐ (See page 29.)

SEF451A

a

ECCS ANALYZER

2001

RPM

● IDLE SW ● NEUTRAL SW
 ● AIRCON SW ● C.A.S.
 ● STARTER SW

● CAR SPEED
 ● CRANKANGLE
 ● SENSOR (R.P.M.T)
 ● KNOCKING
 ● CYLINDER HEAD
 ● TEMPERATURE
 ● ALTITUDE
 ● AIR TEMP
 ● AIR FLOW
 ● METER
 ● BATTERY

● IGN FUEL PUMP
 ● IDLE EGR
 ● SPEED CONTROL
 ● NO 1 NO 2 NO 3 NO 4 NO 5 NO 6
 INJECTOR

SEF452A

Check neutral switch.

1. Put in "Neutral position."
2. Neutral switch lamp: "ON"

N.G. → **B** (See page 30.)

O.K.

ECCS ANALYZER

2001

RPM

● IDLE SW ● NEUTRAL SW
 ● AIRCON SW ● C.A.S.
 ● STARTER SW

● CAR SPEED
 ● CRANKANGLE
 ● SENSOR (R.P.M.T)
 ● KNOCKING
 ● CYLINDER HEAD
 ● TEMPERATURE
 ● ALTITUDE
 ● AIR TEMP
 ● AIR FLOW
 ● METER
 ● BATTERY

● IGN FUEL PUMP
 ● IDLE EGR
 ● SPEED CONTROL
 ● NO 1 NO 2 NO 3 NO 4 NO 5 NO 6
 INJECTOR

SEF453A

Check air conditioner switch.

1. Switch air conditioner "ON"
2. Air conditioner switch lamp: "ON"

N.G. → **C** (See page 30.)

O.K.

ECCS ANALYZER

2001

RPM

● IDLE SW ● NEUTRAL SW
 ● AIRCON SW ● C.A.S.
 ● STARTER SW

● CAR SPEED
 ● CRANKANGLE
 ● SENSOR (R.P.M.T)
 ● KNOCKING
 ● CYLINDER HEAD
 ● TEMPERATURE
 ● ALTITUDE
 ● AIR TEMP
 ● AIR FLOW
 ● METER
 ● BATTERY

● IGN FUEL PUMP
 ● IDLE EGR
 ● SPEED CONTROL
 ● NO 1 NO 2 NO 3 NO 4 NO 5 NO 6
 INJECTOR

SEF454A

Check starter switch.

1. Turn ignition switch to "START".
2. Starter switch lamp: "ON"

N.G. → **D** (See page 31.)

O.K. ↓
b

ⓑ

Check ignition system.

1. Push check button.
2. IGN. monitor lamp: "ON"

After checking ignition system, return ignition switch to "ACC" or "OFF".

SEF455A

N.G. → ⓔ (See page 32.)

O.K.

Check fuel pump control system.

1. Push check button.
2. Fuel pump lamp: goes on and off alternately.

Before checking, return ignition switch to "ON".

SEF456A

N.G. → ⓕ (See page 33.)

O.K.

Check E.G.R. control system.

1. Push check button.
2. E.G.R. lamp: brightens and dims alternately.
3. At the same time check operating sound of V.C.M. solenoid valve.

SEF457A

N.G. → ⓖ (See page 34.)

O.K.

ⓒ

(C)

ECCS ANALYZER

0001

SEF458A

Check idle speed control system.

1. Push check button.
2. Idle speed control lamp: brightens and dims alternately.
3. At the same time check operating sound of V.C.M. solenoid valve.

N.G. → (H) (See page 35.)

O.K.

ECCS ANALYZER

0001

SEF459A

Check Battery voltage.

1. Push check button.
2. O.K. monitor lamp: "ON"

N.G. → (J) (See page 36.)

O.K.

ECCS ANALYZER

0001

SEF460A

Check air flow meter.

1. Push check button.
2. O.K. monitor lamp: "ON"

N.G. → (K) (See page 36.)

After engine start:

ECCS ANALYZER
SEF461A

Check C.A.S. signal.

1. Start engine.
2. C.A.S. lamp: "ON"

Before starting engine, return rotary switch to "E.G.R." position.

N.G. → **L** (See page 37.)

O.K.

ECCS ANALYZER
SEF462A

Check E.F.I. and injectors.

1. Start engine.
2. E.F.I. lamp: brightens and dims alternately.
Injector lamps: "ON"

N.G. → **M** (See page 37.)

O.K.

After warming up and still running:

ECCS ANALYZER
SEF463A

Check E.G.R. control system.

1. Depress accelerator pedal slightly.
2. Push check button.
3. Engine speed should vary.
4. E.G.R. lamp: brightens and dims alternately (during engine speed change).

N.G. → **G** (See page 34.)

O.K.

d

d

Check idle speed control system.

1. Depress accelerator pedal slightly.
2. Push check button.
3. Engine speed should vary.
4. Idle speed control lamp: brightens and dims alternately (during engine speed change).

N.G. → **H** (See page 35.)

SEF464A

O.K.

Check battery voltage.

1. Push check button.
2. O.K. monitor lamp: "ON"

N.G. → **J** (See page 36.)

SEF465A

O.K.

Check air flow meter.

1. Push check button and increase engine speed.
2. O.K. monitor lamp: "OFF" → "ON" → "OFF"

N.G. → **K** (See page 36.)

SEF466A

O.K.

e

e

ECCS ANALYZER

750

Check air temperature sensor.

1. Push check button.
2. O.K. monitor lamp: "ON"

N.G. → **N** (See page 38.)

SEF467A

O.K.

ECCS ANALYZER

750

Check altitude sensor (barometric pressure sensor).

1. Push check button.
2. O.K. monitor lamp: "ON"

N.G. → **P** (See page 39.)

SEF468A

O.K.

ECCS ANALYZER

750

Check cylinder head temperature sensor.

1. Push check button.
2. O.K. monitor lamp: "ON"

N.G. → **Q** (See page 39.)

SEF469A

O.K.

f

f

ECCS ANALYZER

SEF470A

Check knocking sensor.

1. Push check button.
2. Depress accelerator pedal forcibly until engine knocks.
3. O.K. monitor lamp: "ON" (after knocking)

N.G. → **R** (See page 40.)

O.K. ↓

ECCS ANALYZER

SEF471A

Check crank angle sensor.

1. Push check button and increase engine speed.
2. O.K. monitor lamp: "OFF" → "ON" → "OFF" ("ON": 1,800 to 2,200 rpm)

N.G. → **L** (See page 37.)

O.K. ↓

ECCS ANALYZER

SEF472A

Check car speed sensor.

1. Push check button.
2. Increase car speed.
3. O.K. monitor lamp: "ON" [car speed 10 km/h (6 MPH) to 30 km/h (19 MPH)]

N.G. → **S** (See page 40.)

TROUBLE-SHOOTING DIAGNOSIS

Electronic control system inspection

Ⓐ Idle switch (Throttle valve switch)

Disconnect 20-pin and 16-pin connectors and measure the resistance between ⑱ and ㉕.

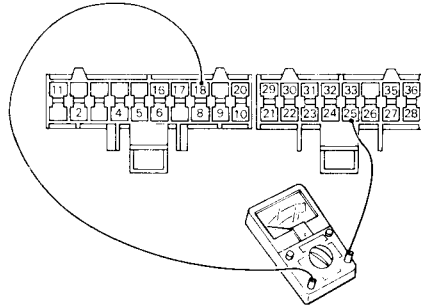

Throttle	Resistance
released	0Ω
depressed	∞Ω

SEF473A

N.G.

Measure the throttle valve switch resistance between ⑱ and ㉕.

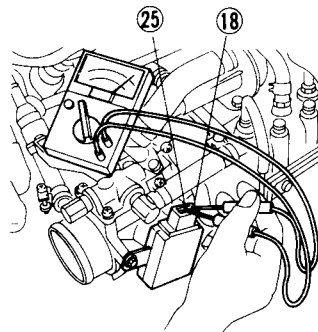

R = 0Ω

SEF116A

O.K.

N.G.

Adjust idle switch.

N.G.

Measure the resistance between ⑱, ㉕ and body ground.

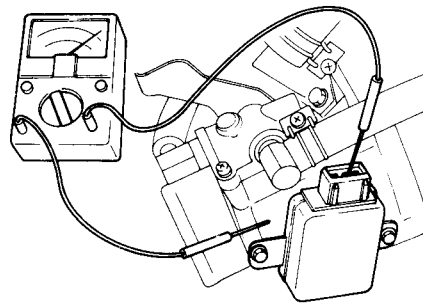

R: ∞Ω

SEF087A

N.G.

Check harness and correct or repair it as necessary.

O.K.

Replace idle switch.

B Neutral/Parking switch

Disconnect 20-pin connector and measure the voltage between ⑩ and body voltage ground.

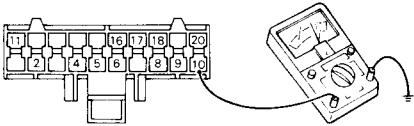

T/M position	Voltage
“N” or “P”	0V
Others	12V

SEF474A

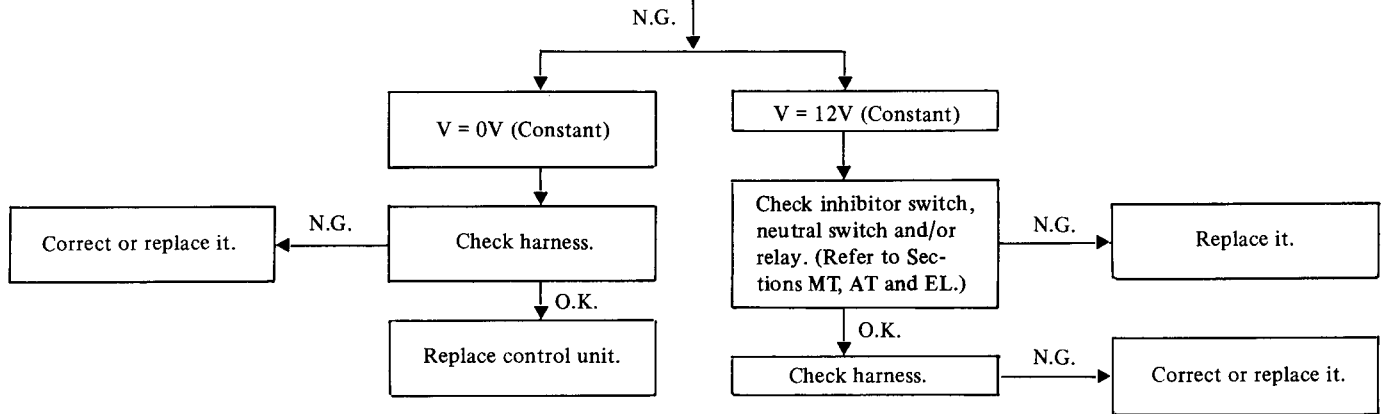

C Air conditioner switch

Disconnect 16-pin connector and measure the resistance between ② and body ground.

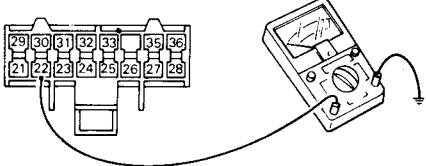

Air conditioner switch	Resistance
ON	12V
OFF	0V

SEF089A

N.G.

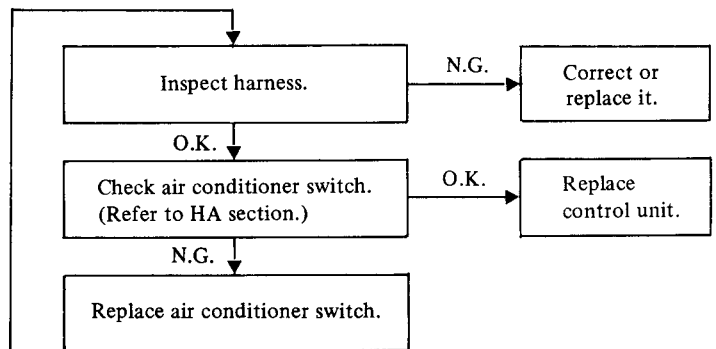

Ⓓ Starter switch

Disconnect 20-pin connector and measure voltage between terminal ⑨ and body ground while cranking engine.

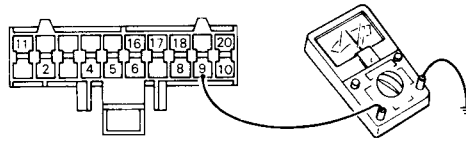

Voltage: Battery voltage

SEF475A

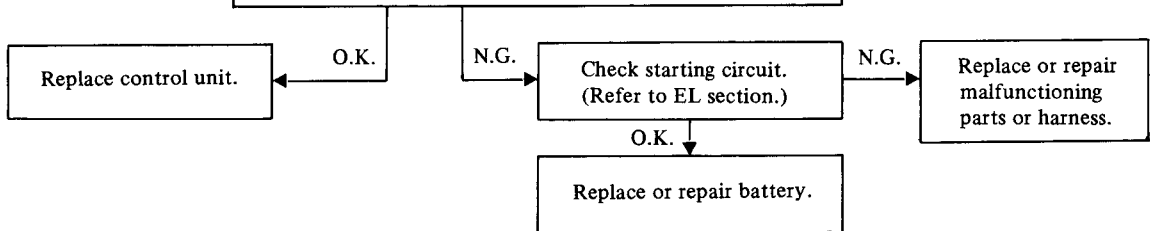

⑤ IGN. (Ignition system)

Disconnect high tension cable from one spark plug and check for hot spark during cranking.

SEF090A

O.K. → Replace or repair spark plug.

N.G. → Check distributor, ignition coil and high tension cable.

N.G. → Replace or repair them if available.

O.K. →

N.G. →

ECCS ANALYZER
2001

Check ignition system.
1. Push check button.
2. IGN. monitor lamp: "ON"

After checking ignition system, return ignition switch to "ACC" or "OFF".

SEF455A

O.K. → Replace power transistor of ignition coil.

N.G. →

Disconnect 20-pin connector and measure the resistance between terminal ⑤ and ground.

R: Except 0 or $\infty \Omega$

SEF478A

O.K. → Replace control unit.

N.G. → Check harness and replace or correct as necessary.

F Fuel pump

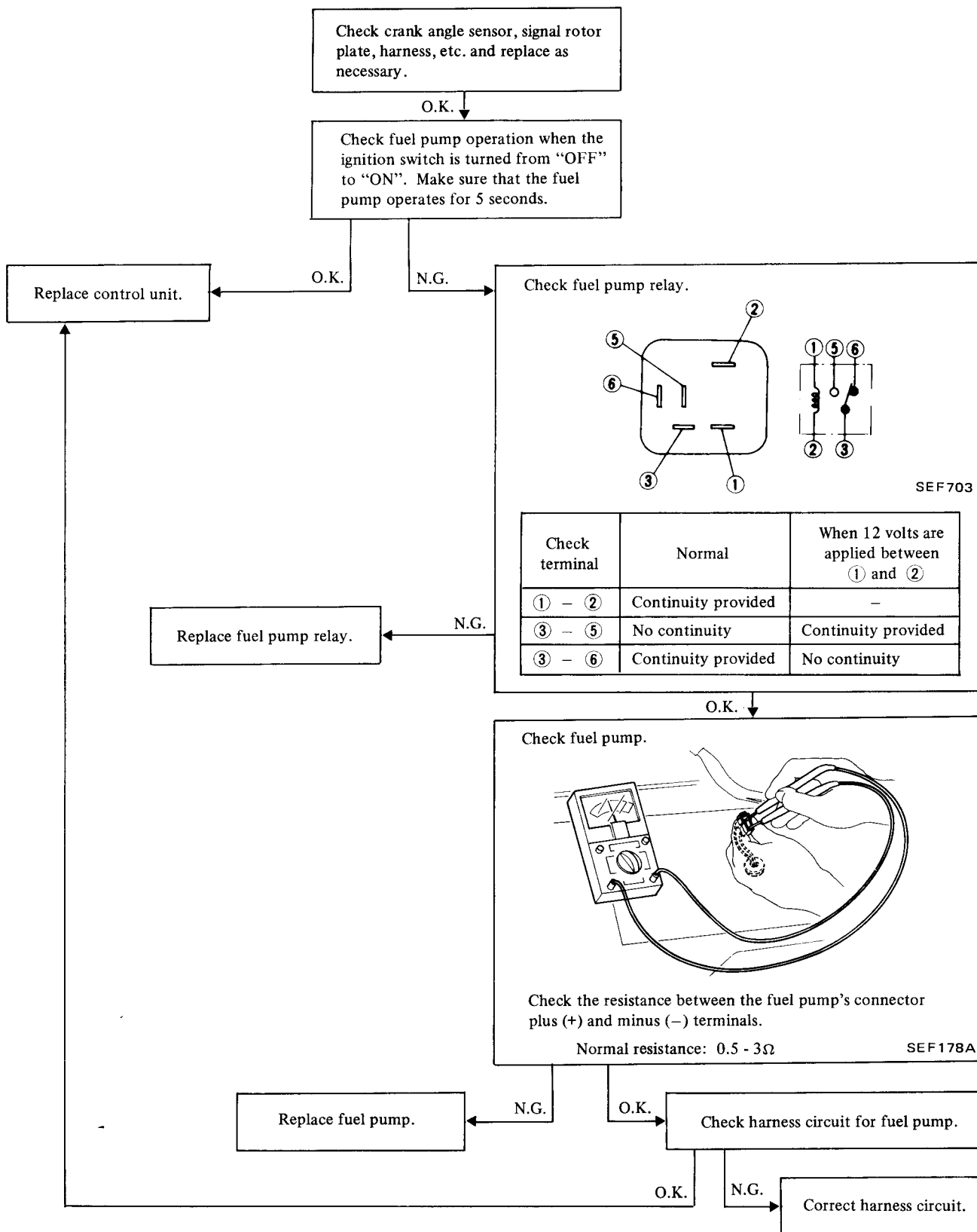

Ⓒ E.G.R.

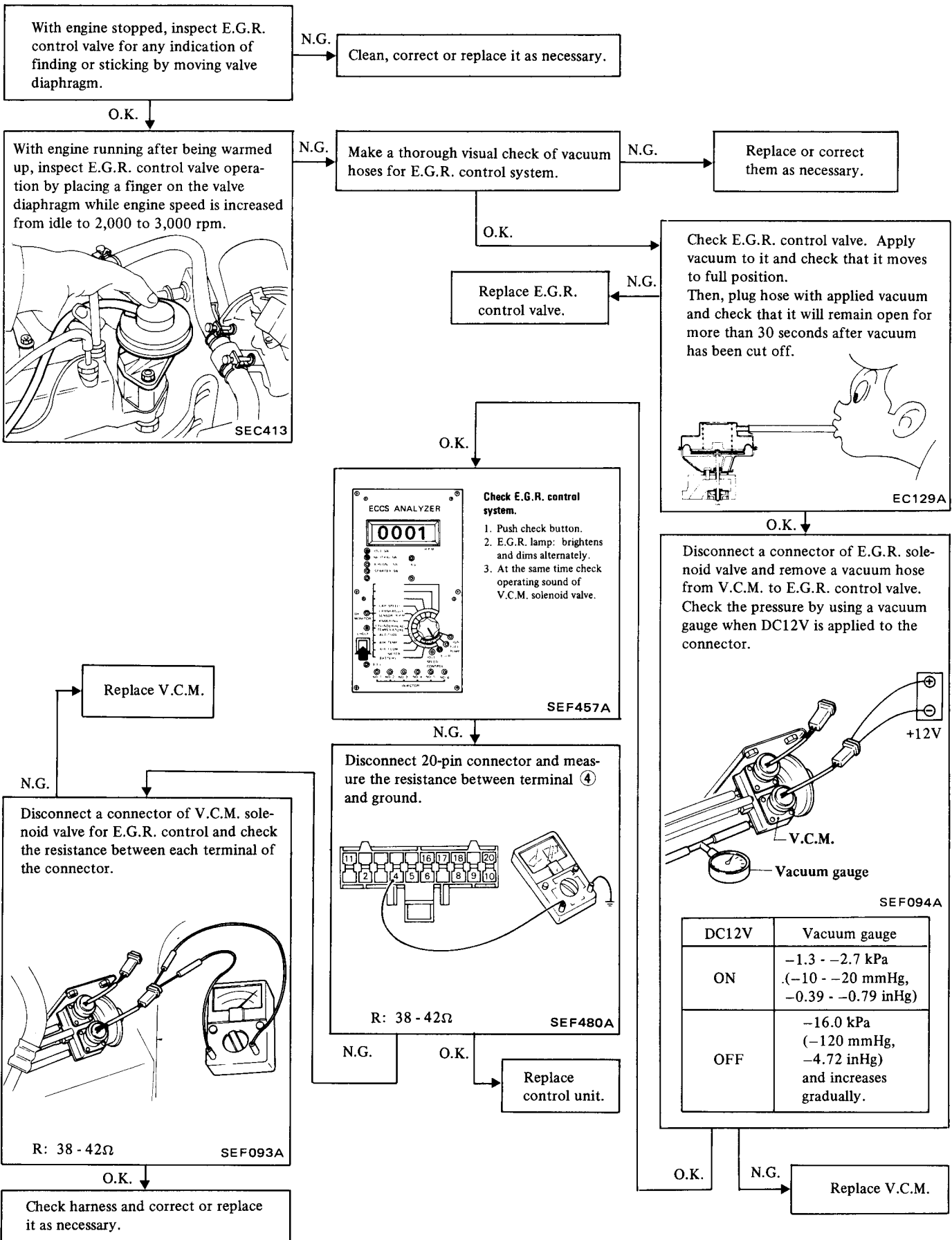

H Idle speed control

After warming up sufficiently, make a thorough visual check of vacuum hoses for idle speed control system.

N.G.

Replace or correct them as necessary.

O.K.

Check A.A.C. valve. Apply vacuum to it and check that it moves to full position. Then, plug hose with applied vacuum and check that it will remain open for more than 30 seconds after vacuum has been cut off.

N.G.

Replace A.A.C. valve.

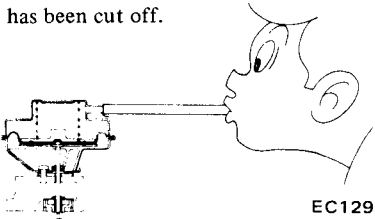

O.K.

Disconnect a connector of I.S.C. solenoid valve and remove a vacuum hose from V.C.M. to A.A.C. valve. Check the pressure by using a vacuum gauge when DC12V is applied to the connector.

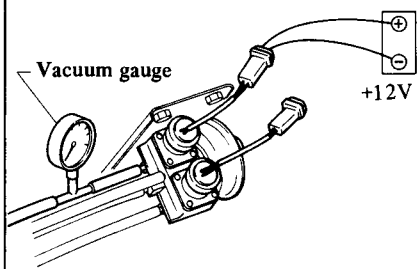

DC12V	Vacuum gauge
ON	-1.3 - -2.7 kPa (-10 - -20 mmHg, -0.39 - -0.79 inHg)
OFF	-16.0 kPa (-120 mmHg, -4.72 inHg) and increases gradually.

SEF173A

Replace V.C.M.

N.G.

O.K.

ECCS ANALYZER

Check idle speed control system.

1. Push check button.
2. Idle speed control lamp: brightens and dims alternately.
3. At the same time check operating sound of V.C.M. solenoid valve.

SEF458A

N.G.

Disconnect 20-pin connector and measure the resistance between terminal ② and ground.

R: 38 - 42Ω

SEF482A

O.K.

Replace control unit.

N.G.

Disconnect a connector of V.C.M. solenoid valve for I.S.C. control and check the resistance between each terminal of the connector.

R: 38 - 42Ω

SEF180A

N.G.

Replace V.C.M.

O.K.

Check harness and correct or replace it as necessary.

J) Battery

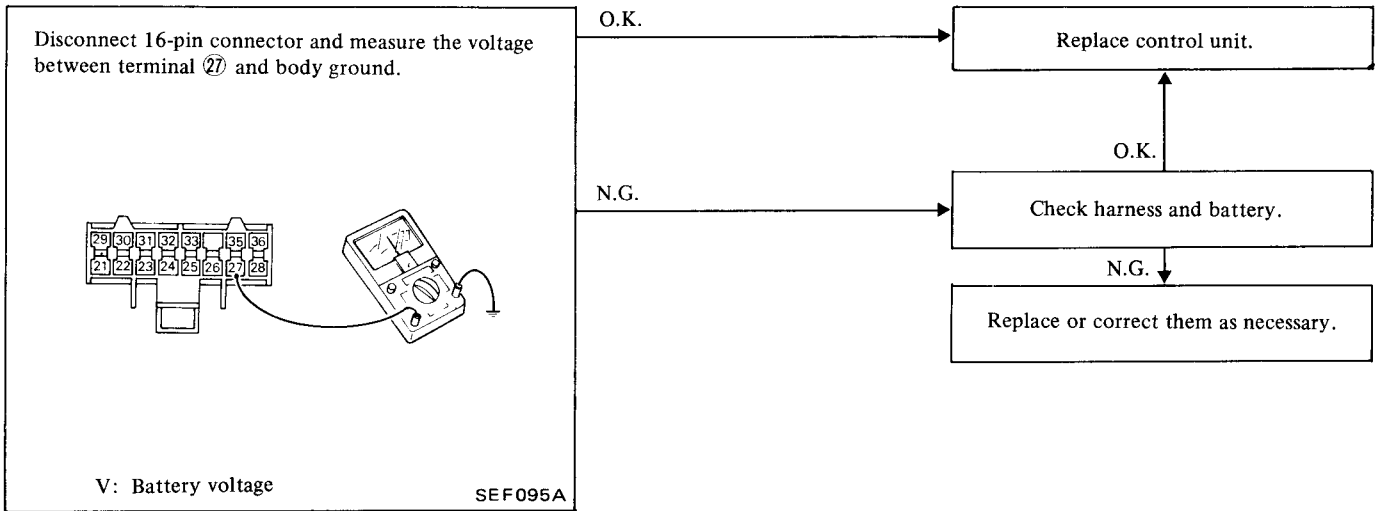

K) Air flow meter

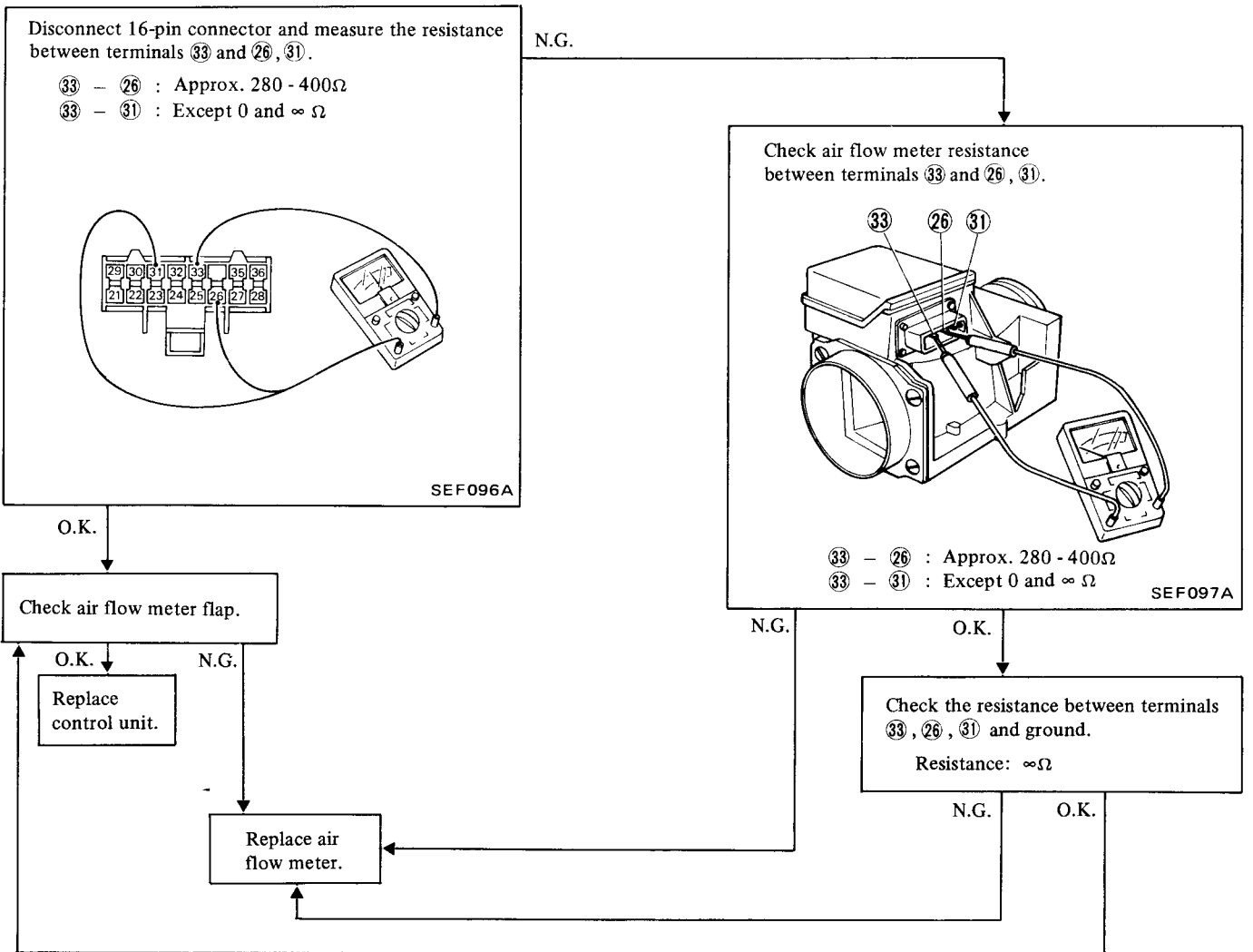

Ⓝ Air temperature

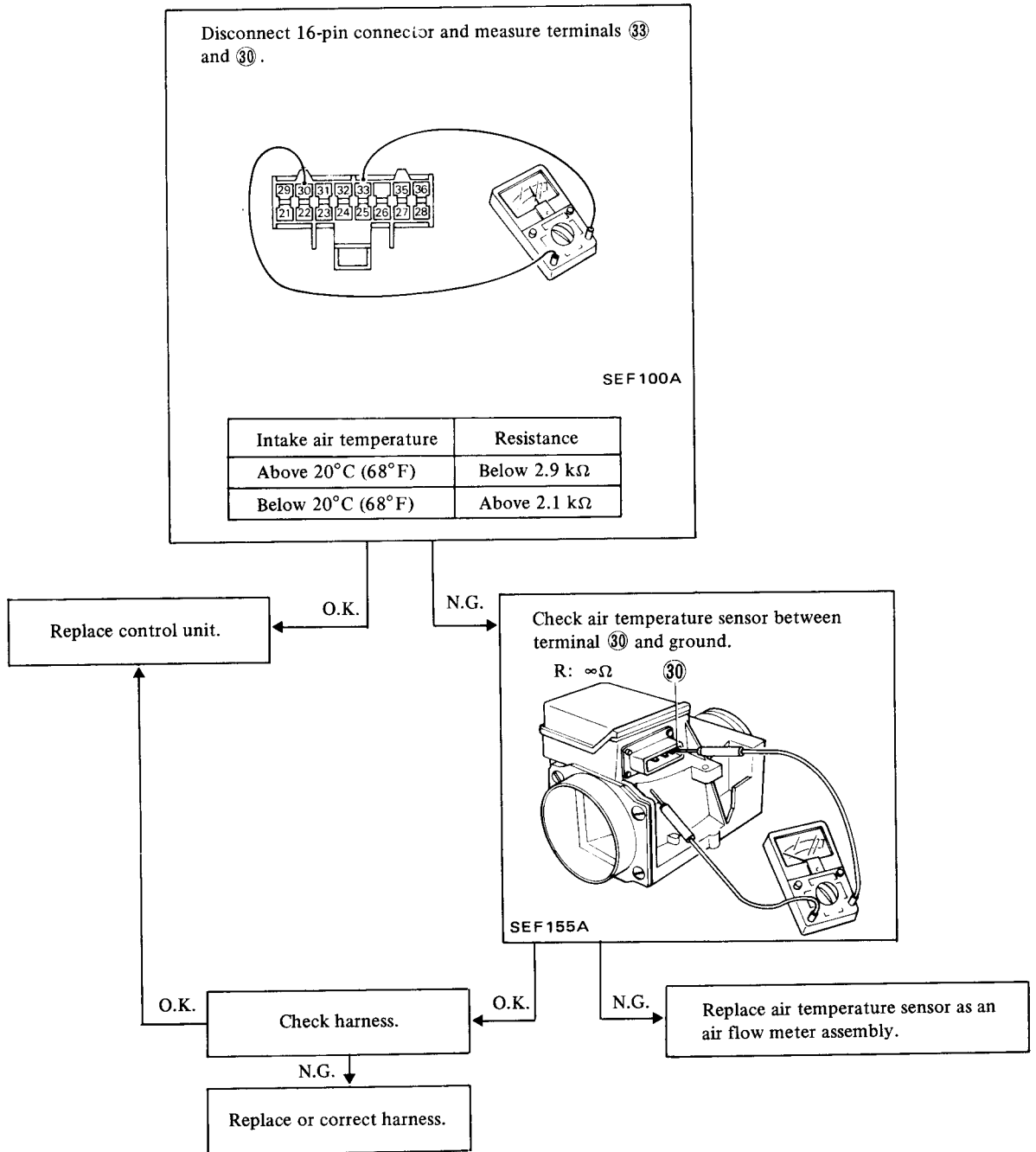

P Altitude (Barometric pressure sensor)

If O.K. monitor lamp does not come on, replace control unit.

Q Cylinder head temperature sensor

Disconnect 16-pin connector and measure the resistance between terminal 23 and body ground.

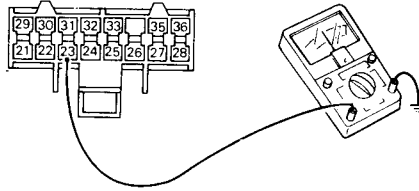

SEF101A

Cylinder head temperature	Resistance
Above 20°C (68°F)	Below 2.9 kΩ
Below 20°C (68°F)	Above 2.1 kΩ

N.G.

Check harness.

O.K.

O.K.

Replace control unit.

Dip the sensor into water maintained at a temperature of 20°C (68°F), 80°C (176°F), etc., and read its resistance.

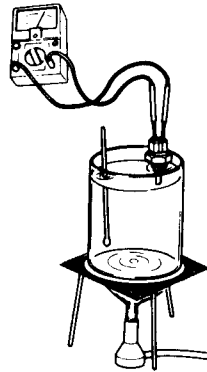

EF329A

CHARACTERISTIC CURVE

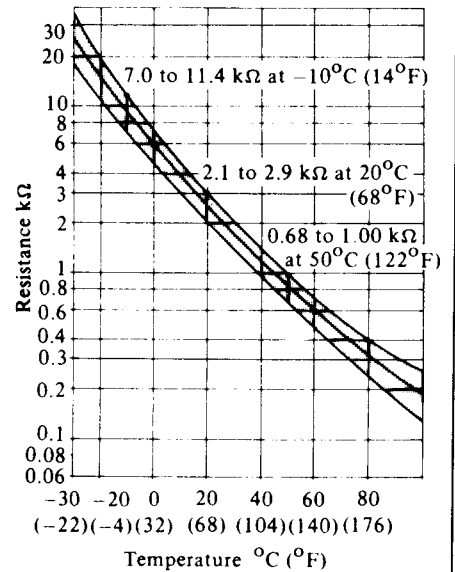

EF334A

O.K.

N.G.

Replace cylinder head temperature sensor.

Ⓜ Knocking (Detonation sensor)

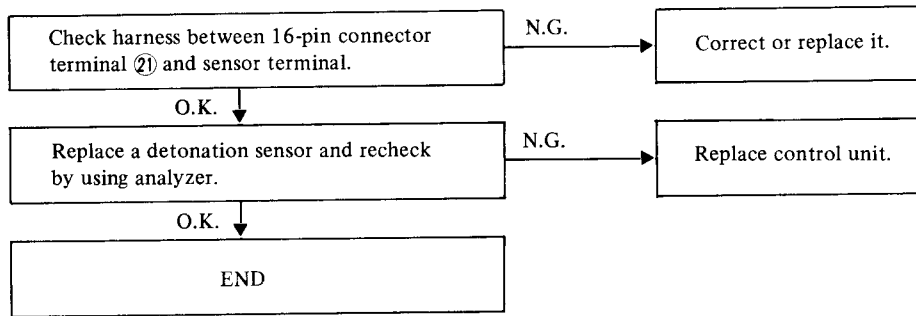

Ⓜ Car speed sensor

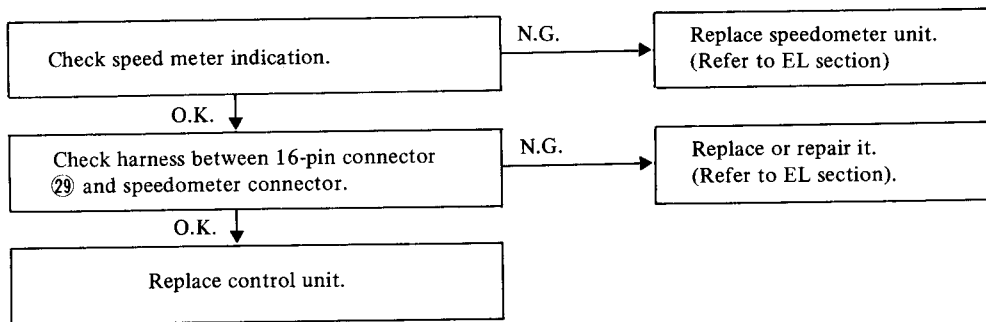

AIR FLOW AND VACUUM CONTROL SYSTEM INSPECTION

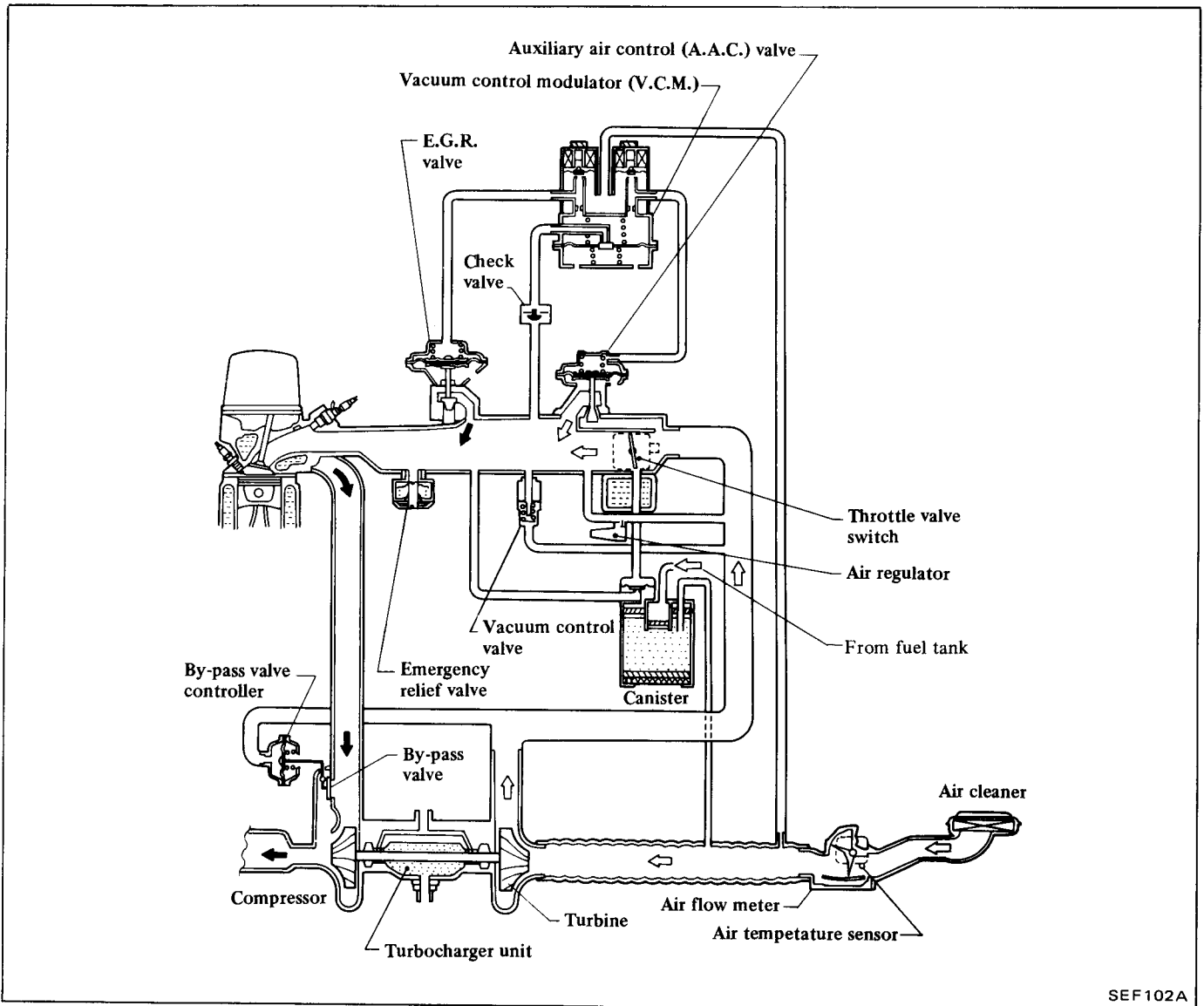

SEF102A

Check hoses, pipes, connections, etc. depending on the problem using air flow and vacuum control systems.

1) Engine starting malfunction or inability to start

- Intake air leakage ...
P.C.V. valve and hoses (Refer to page 110.)
Air flow meter hoses and connections
V.C.M. hoses -
Canister purge and control hoses
Vacuum control valve hose
Vacuum control valve (V.C.V.) operation
Oil filler cap seals and dipstick
- A.A.C. valve ...
V.C.M. hose and connection
A.A.C. valve hose and connection
A.A.C. valve operation

2) Engine stall

- Air regulator ...
Air regulator hoses and connections
Air regulator operation
- Intake air leakage ...
V.C.V. hose and connection
V.C.V. operation
Canister hose
- E.G.R. control valve ...
V.C.M. hose and connection
Check valve
E.G.R. valve hose
E.G.R. valve operation

3) Improper idle

- Intake air leakage (Refer to the item above.)
- Air regulator (Refer to the item above.)
- E.G.R. control valve (Refer to the item above.)

- V.C.M. hoses
- A.A.C. valve hose
- etc.
- 4) Driving malfunction
- Throttle chamber operation
- Air flow meter operation
- Air cleaner filter (Refer to MA section.)
- Air regulator and hoses
- Intake air leakage (Refer to the item above.)
- Turbocharger (Refer to TURBOCHARGER.) ...
By-pass valve controller
By-pass valve
Emergency relief valve, etc.

When malfunctions are found in hoses and connections, they should be replaced with new ones.

Mixture ratio feedback system inspection

Preparation

1. Make sure that the following parts are in good order.

- Battery
- Ignition system
- Engine oil and coolant levels
- Fuses
- E.F.I. harness connectors
- E.C.C.S. harness connectors
- Vacuum hoses
- Air intake system
(oil filler cap, oil level gauge, etc.)
- Valve clearance, engine compression

2. On air conditioner equipped models, checks should be carried out while the air conditioner is "OFF".

3. On automatic transmission equipped models, when checking idle rpm, ignition timing and mixture ratio, checks should be carried out while shift lever is in "D" position.

WARNING:

- a. When selector lever is shifted to "D" position, apply parking brake and block both front and rear wheels with chocks.
- b. Depress brake pedal while accelerating the engine to prevent forward surge of car.
- c. After the adjustment has been made, shift the lever to the "N" or "P" position and remove wheel chocks.

Inspection procedure for E.F.I. engine

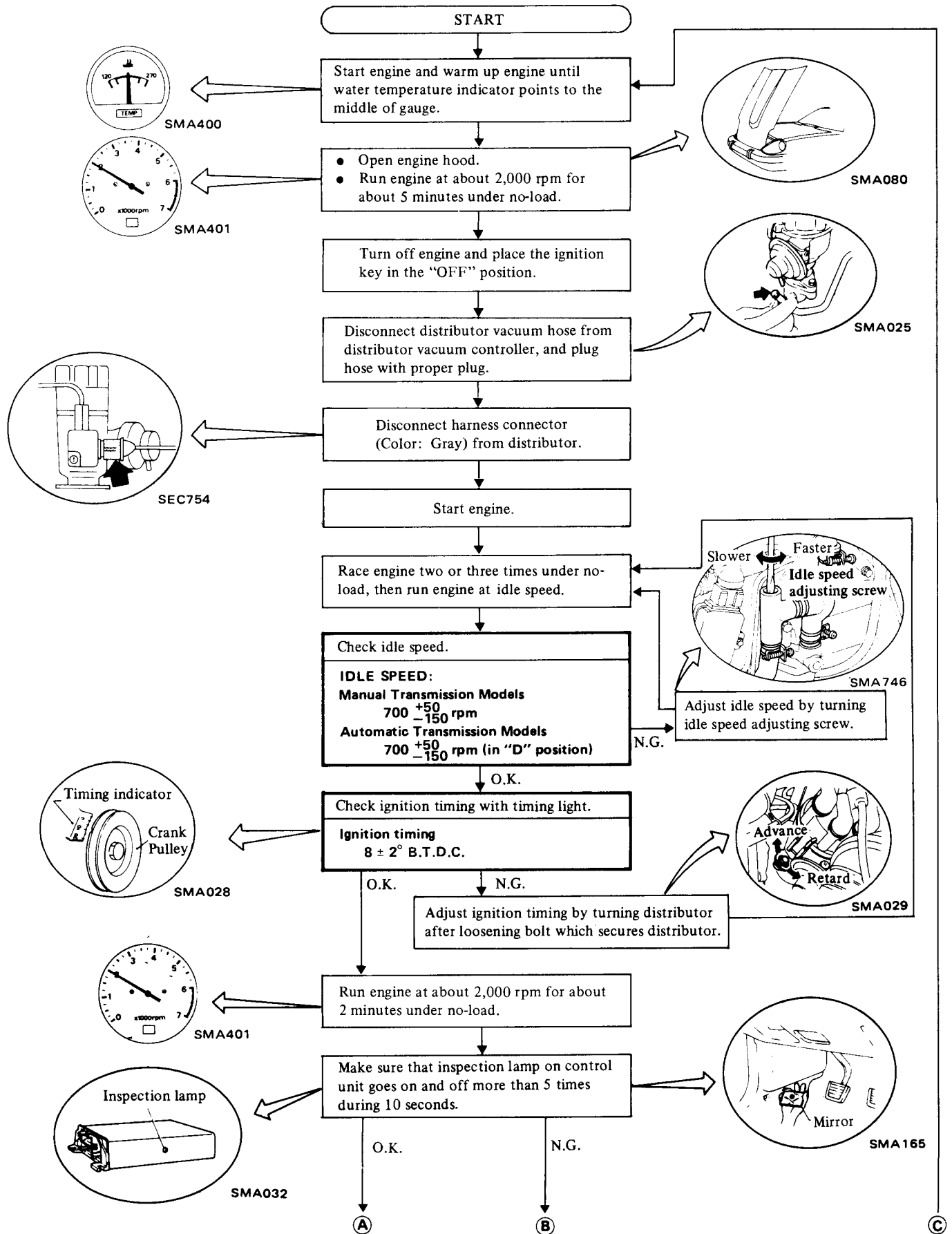

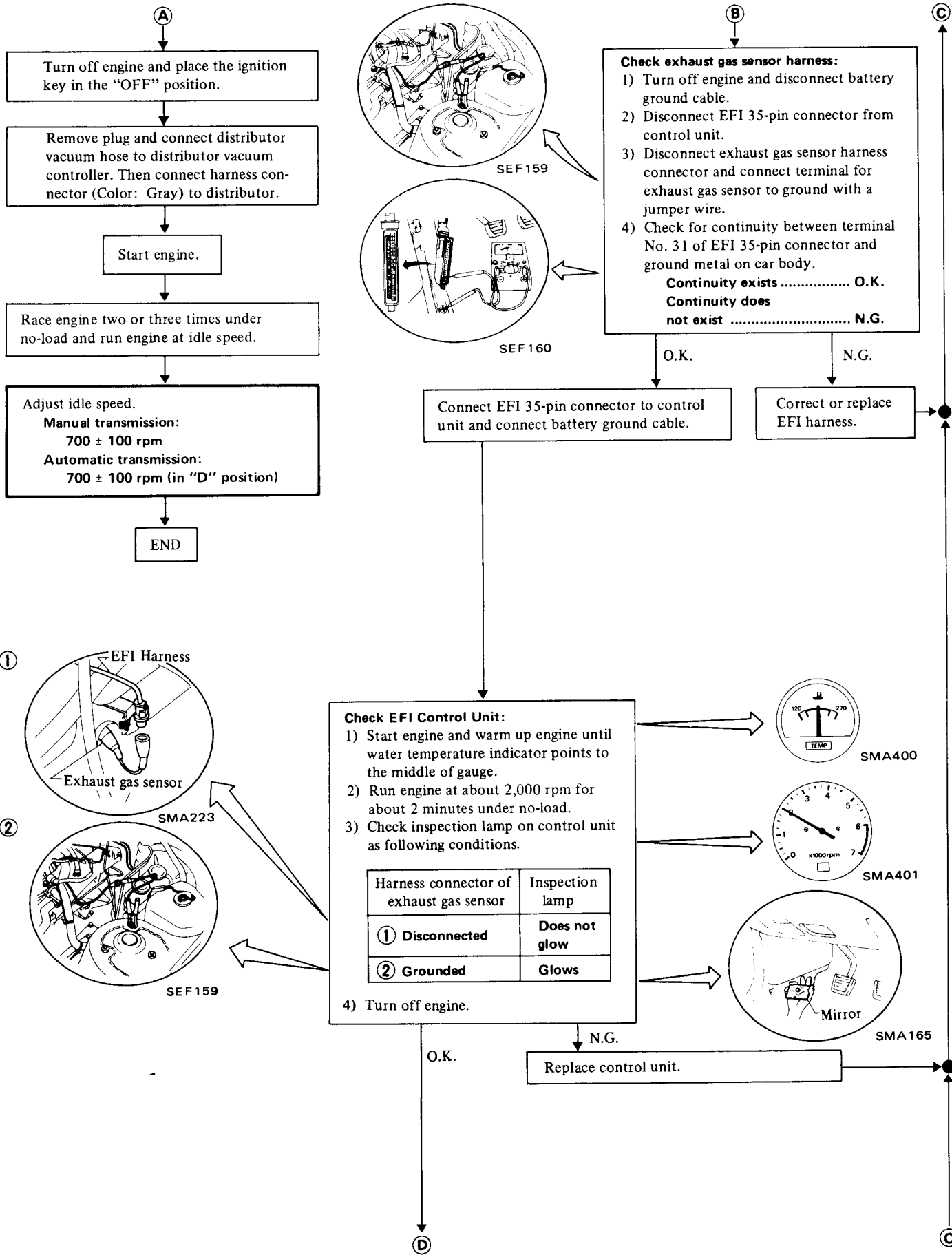

Note:
Keep throttle valve switch harness connector at least 10 cm (3.9 in) away from high tension cable, to prevent malfunction due to reception of external noise.

Note:
a. The idle mixture ratio of EFI car is set so lean that "CO" % remains almost unchanged when adjustment is made under normal condition. Therefore, when adjusting idle mixture ratio, to distinguish variation in "CO" %, a full enrichment must be temporarily given to idle mixture setting to make it richer.
b. Make lead wire as follows:
Use flat plate terminals 3 mm (0.12 in) wide, 0.8 mm (0.031 in) thick as male terminals. Place flat plate terminals parallel with each other and keep distance between inside faces 2 mm (0.08 in). Solder lead wire to each terminal and wrap insulation tape around soldered portion.

Note:
a. When measuring "CO" %, insert probe into tail pipe more than 0.4 m (16 in).
b. Use "CO" -meter after it is fully warmed up.

Note:
The air by-pass screw which has been preset at the factory should be adjusted to lower exhaust emission as directed by official inspections.
The seal plug which seals air by-pass screw should not be removed during routine maintenance.
Adjusting mixture using other than the following method may violate Federal or other State and Provincial laws.

Note:
After drilling, be sure to remove shavings and dust.

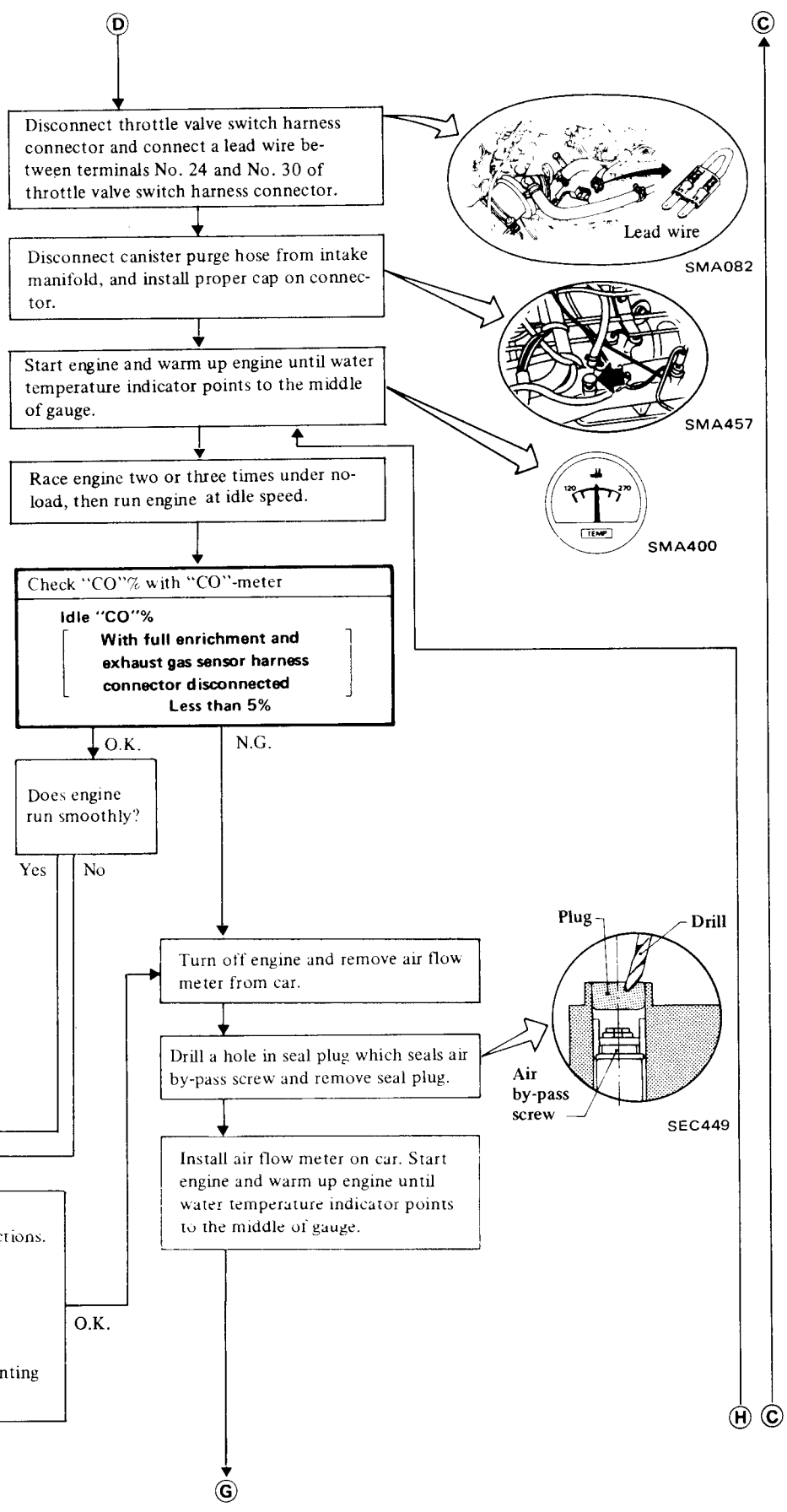

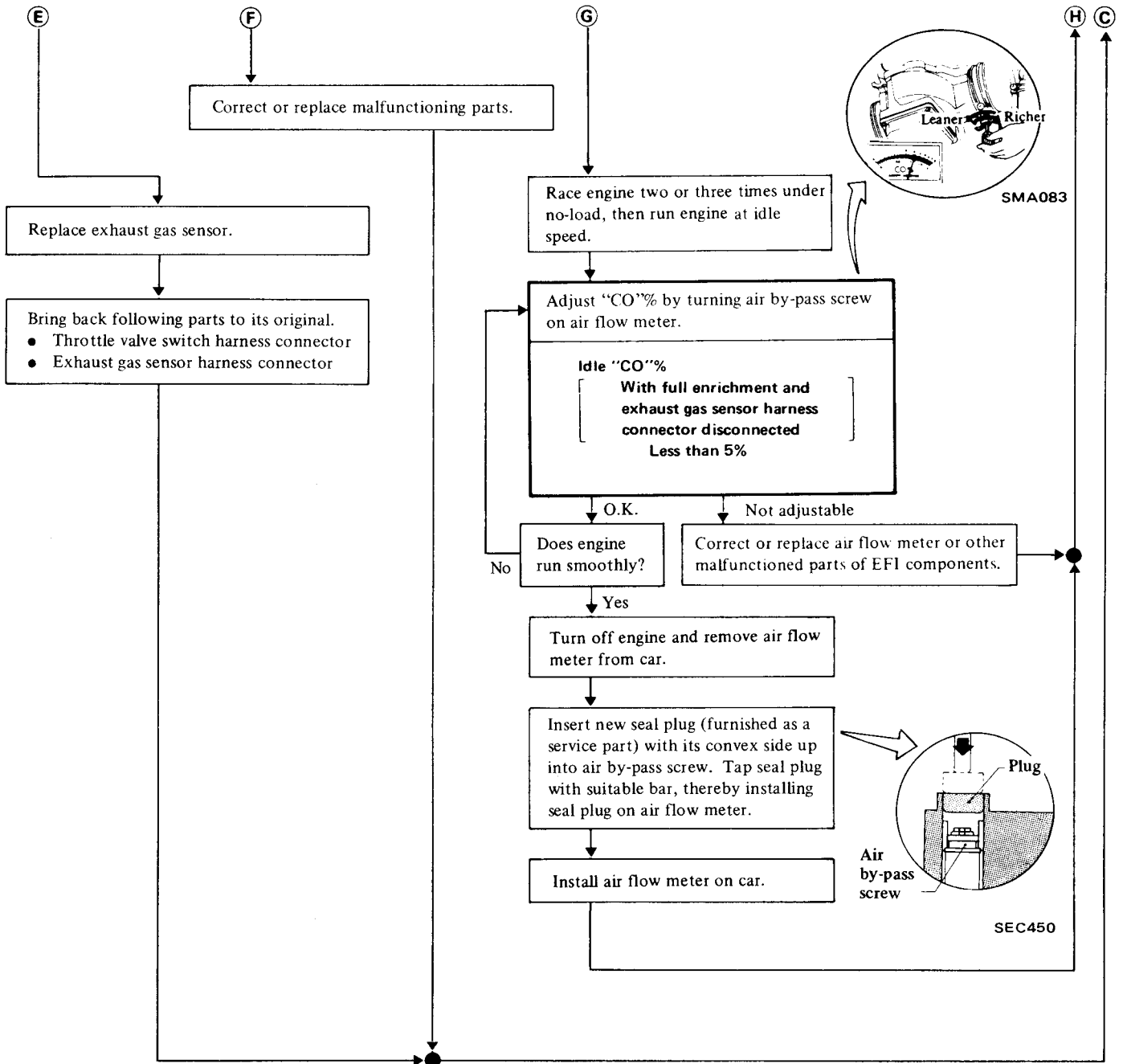

Inspection procedure for E.C.C.S. engine

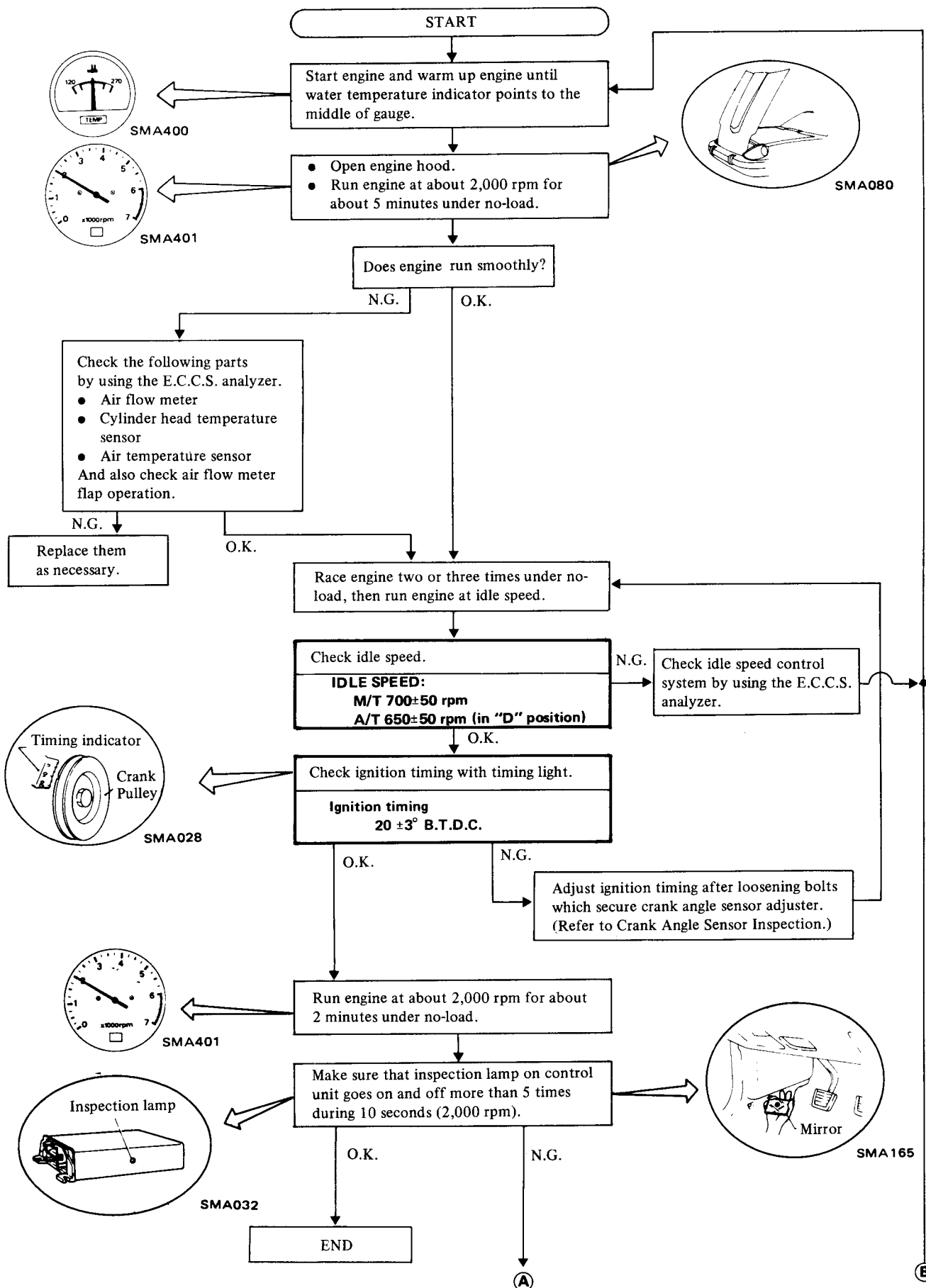

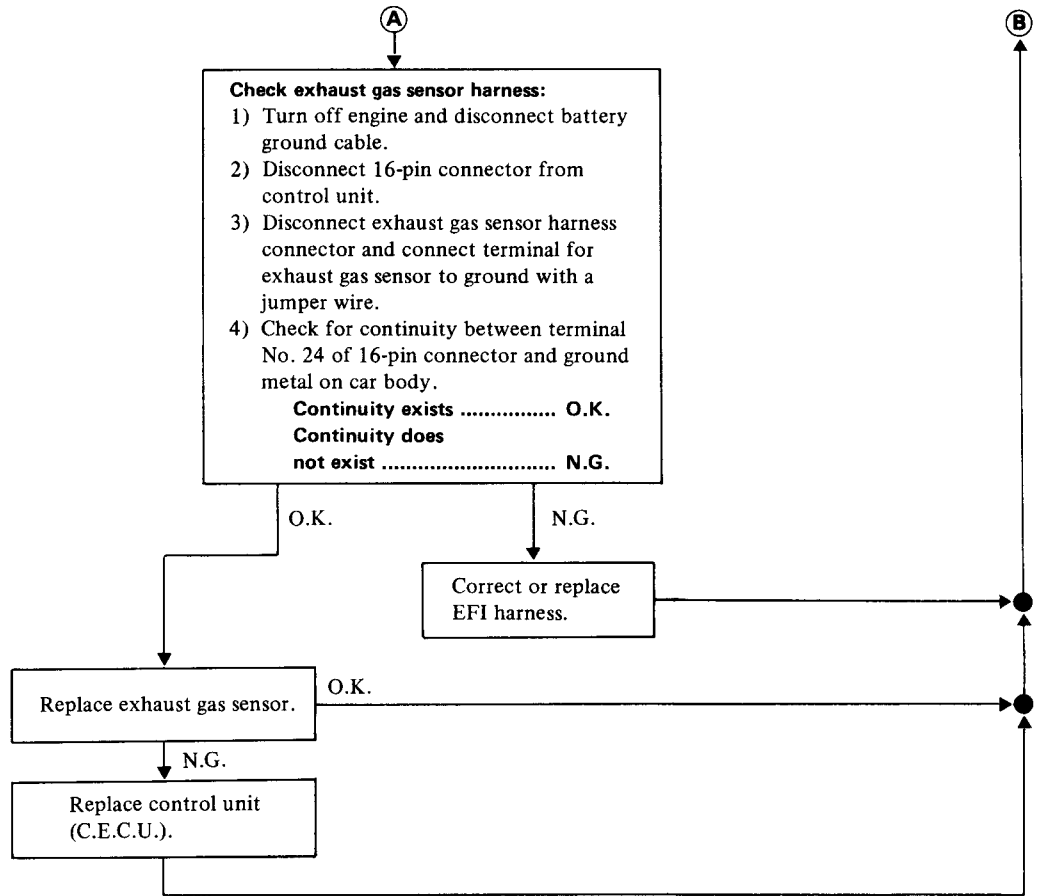

E.F.I. SYSTEM OPERATION

FUEL INJECTION CONTROL

The fuel injectors are electrically connected, in parallel, in the control unit. All injectors receive the injection signal from the control unit at the same time. Therefore, injection is made independently of the engine stroke cycle (intake, combustion, and exhaust). In the six-cylinder engine,

injection is made once every revolution of the engine, triggered by the ignition coil.

Fuel in this E.F.I. system is not injected directly into the cylinder, but is injected into the intake port. Therefore, the air-fuel mixture is drawn into the cylinder when the intake valve opens to start the intake stroke.

SIGNALS FOR CONTROL UNIT

An electrical signal from each sensor is introduced into the control unit for computation. The open-valve time period of the injector is controlled by the duration of the pulse computed in the control unit.

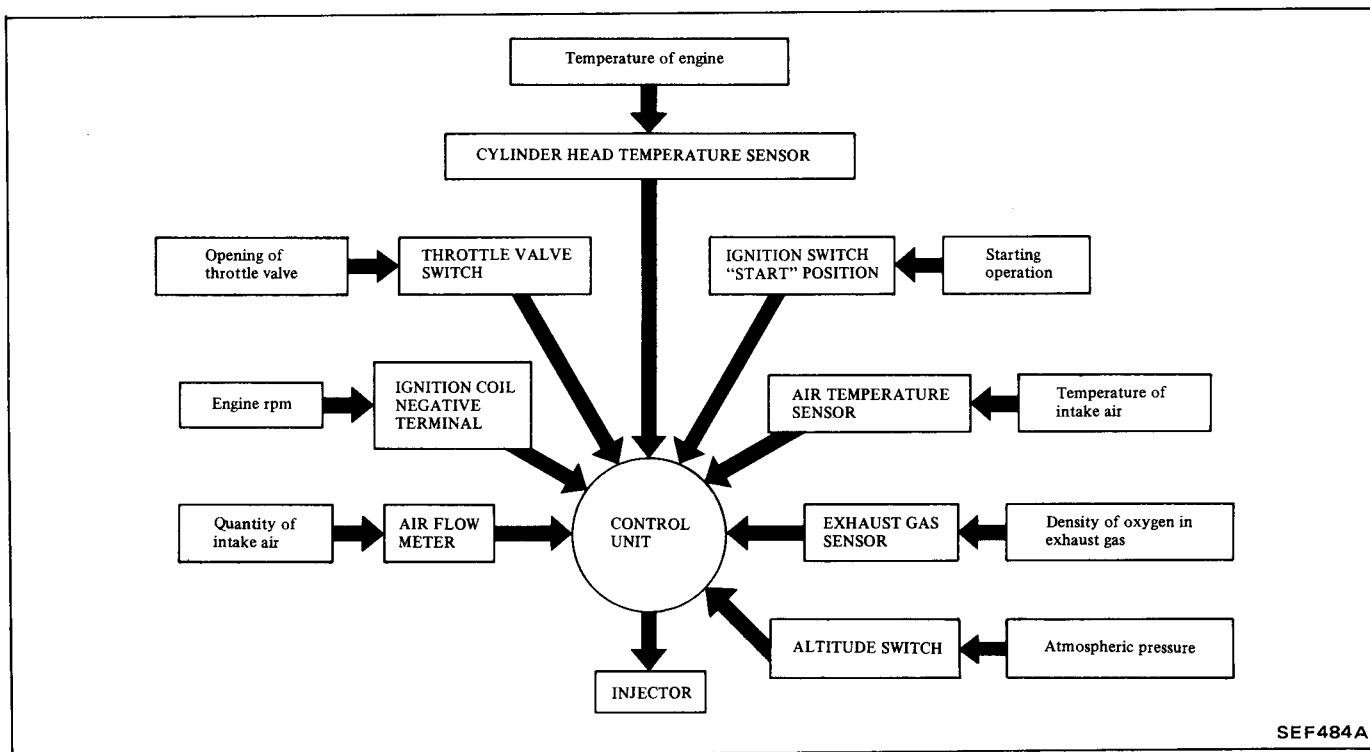

FUEL FLOW SYSTEM

Fuel is drawn from the fuel tank into the fuel pump, from which it is discharged under pressure. As it flows through the mechanical fuel damper, pulsation in the fuel flow is damped. Then, the fuel is filtered in the fuel filter, goes through the fuel line, and is injected into the intake port.

Surplus fuel is led through the pressure regulator and is returned to the fuel tank. The pressure regulator controls the injection pressure in such a manner that the pressure difference between the fuel pressure and the intake manifold vacuum is always 250.1 kPa (2.55 kg/cm², 36.3 psi).

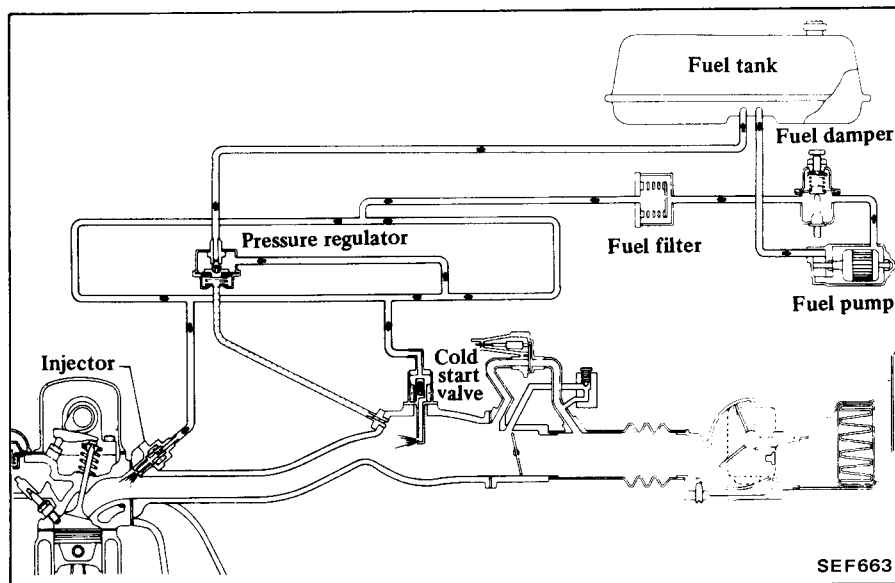

FUEL PUMP

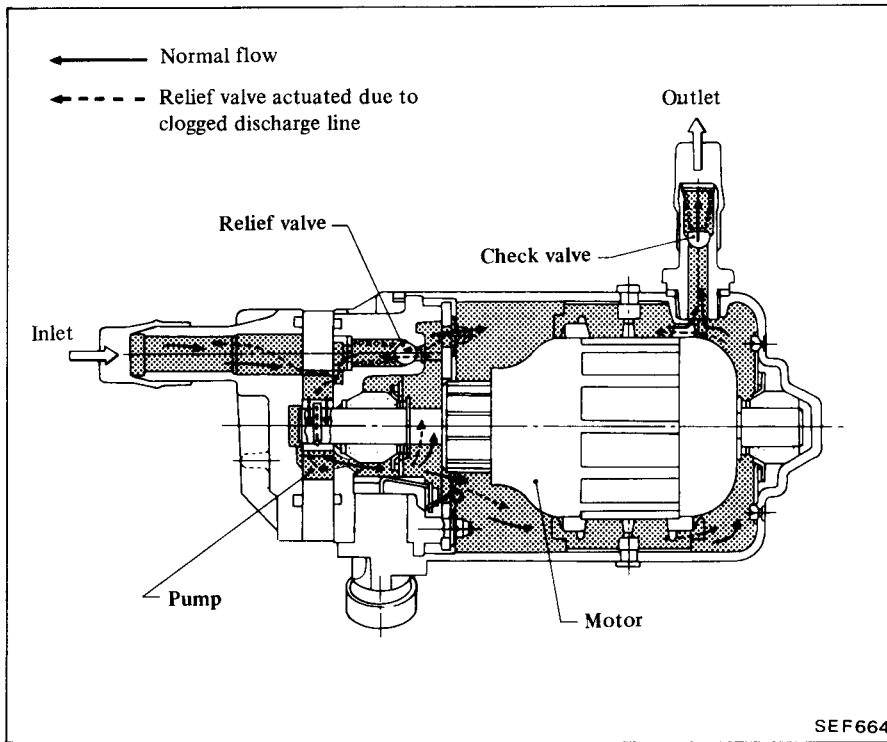

The fuel pump is a wet type pump where the vane rollers are directly coupled to a motor which is filled with fuel.

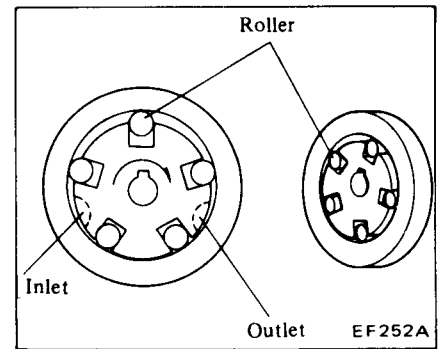

A relief valve in the pump is designed to open when the pressure in the fuel line rises over 294 to 441 kPa (3.0 to 4.5 kg/cm², 43 to 64 psi) due to malfunction in the pressure system.

The check valve prevents abrupt drop of pressure in the fuel pipe when stopping the engine.

Fuel pump circuit

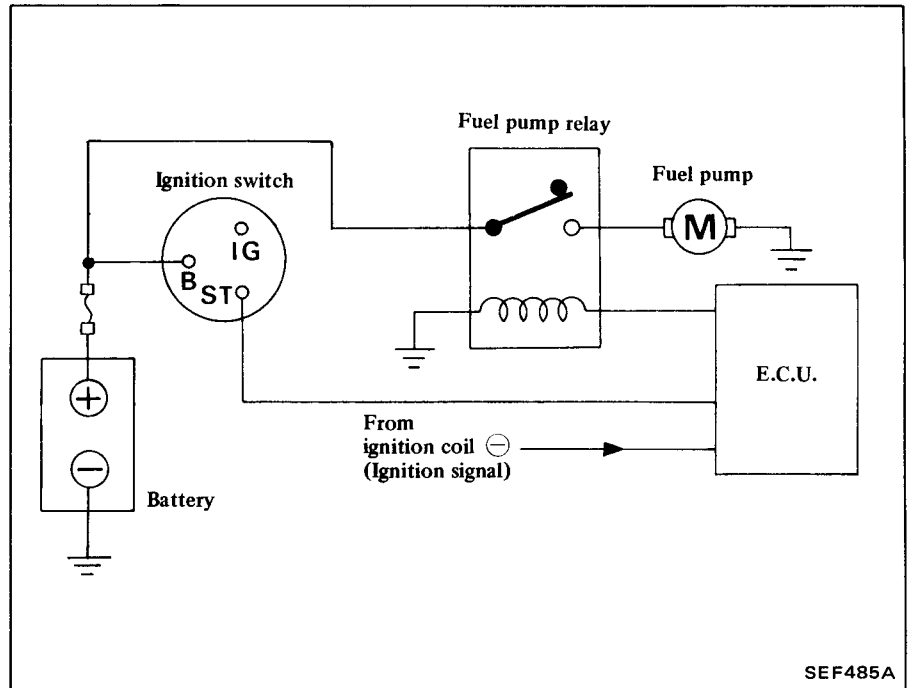

Fuel pump operation

Ignition switch position	Fuel pump operation	Engine speed	Fuel pump relay state
ON	Operates for a few seconds	Stops	ON for a few seconds
START	Operates	Cranking speed	ON
ON	Stops	Below 50 rpm	OFF
	Operates	Above 50 rpm	ON

FUEL DAMPER

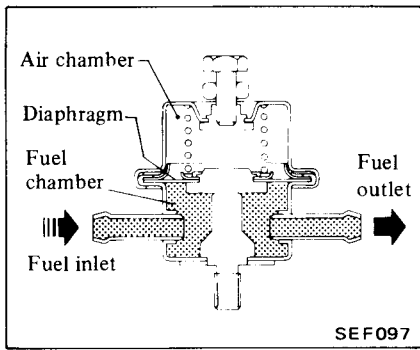

The fuel damper acts like a shock absorber in fuel flow discharged from the fuel pump. There are not adjustments on this damper.

Change in the pump discharge pressure is monitored by the diaphragm and spring, which vary the volume of the fuel chamber.

FUEL FILTER

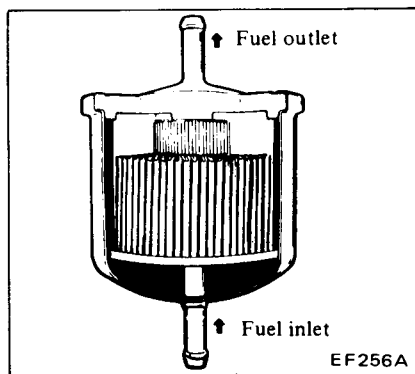

The fuel filter is placed between the fuel damper and the injector, and is used to remove foreign matter in the fuel. Water in the fuel is collected at the bottom of the filter casing.

PRESSURE REGULATOR

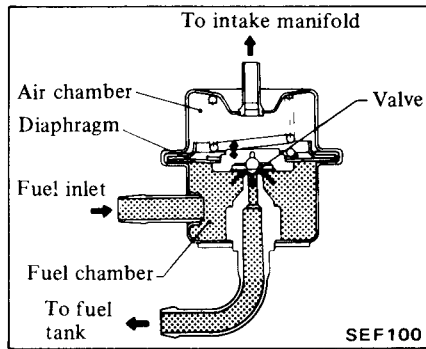

The pressure regulator controls the pressure of fuel so that a pressure difference of 250.1 kPa (2.55 kg/cm², 36.3 psi) can be maintained between the fuel pressure and intake manifold vacuum. The pressure regulator is divided into the air chamber and fuel chamber by the diaphragm. Intake manifold vacuum is introduced into the air chamber, thereby keeping differential pressure constant causing excessive fuel to return to the fuel tank through the return side port. This constant differential pressure provides optimum fuel injection in every mode of engine operation.

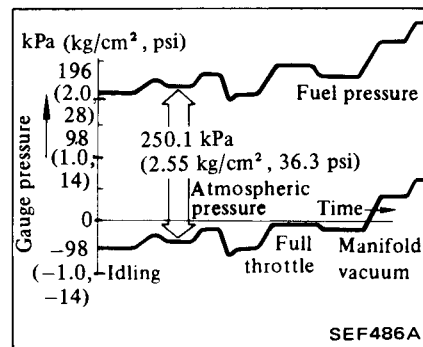

Inspection

If the fuel pressure is other than that specified, first check the fuel pump and then check the following items:

If fuel pressure is too high:

Vacuum hose connected to pressure regulator poorly, clogged fuel return piping, or faulty pressure regulator.

If fuel pressure is too low:

Clogged fuel pump, fuel filter, or fuel tank; leak in the fuel system, or faulty pressure regulator.

Replacement

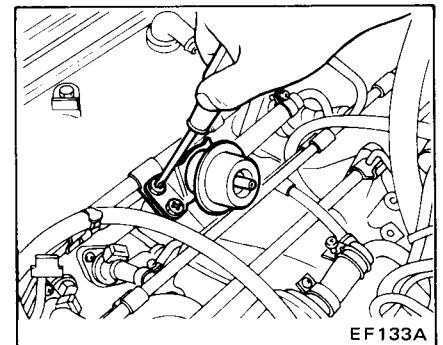

1. Reduce fuel line pressure to zero.
2. Disengage vacuum tube connecting regulator to intake manifold from pressure regulator.
3. Remove screws securing pressure regulator.
4. Unfasten hose clamps, and disconnect pressure regulator from fuel hose.

Place a rag under pressure regulator to prevent splashing of fuel.

5. To install pressure regulator, reverse the order of removal.
6. For installation of fuel hose, refer to Fuel Hose.

FUEL HOSE

Make sure that all low pressure fuel hoses are fully inserted and are free from undue strain before clamping.

When removing or installing high pressure fuel hose, observe the following:

CAUTION:

- a. Do not reuse fuel hose clamps after loosening.
- b. Clean dust and dirt from parts with compressed air when assembling.
- c. Tighten high pressure rubber hose clamp so that clamp end is 3 mm (0.12 in) from hose end or screw position (wider than other portions of clamp) is flush with hose end.

- ⊕ : Fuel hose clamps
- 1.0 - 1.5 N·m
 - (0.10 - 0.15 kg-m,
 - 0.7 - 1.1 ft-lb)

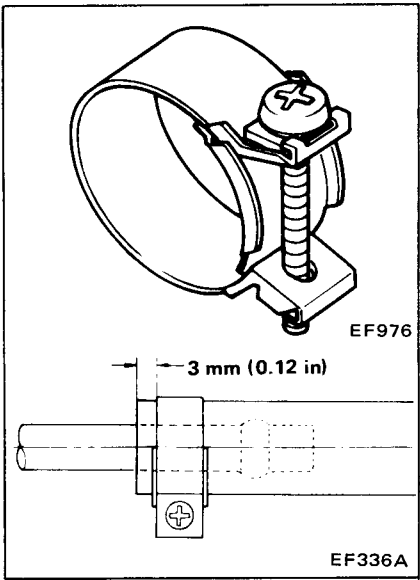

- d. When tightening hose clamp, ensure that screw does not come into contact with adjacent parts.

Insert high pressure fuel hoses into their proper positions as instructed below.

- Type (A): Insert rubber hose until its end contacts unit.
- Type (B): Push end of rubber hose onto fuel pipe until it contacts inner bulge.
- Type (C): Push end of rubber hose onto fuel pipe until it is 33 mm (1.30 in) from end of pipe.
- Type (D): Push end of rubber hose with hose socket onto unit by hand as far as they will go. Clamp is not necessary at this connection.
- Type (E): Push end of injector rubber hose onto fuel pipe until it is 28 mm (1.10 in) from end of pipe.

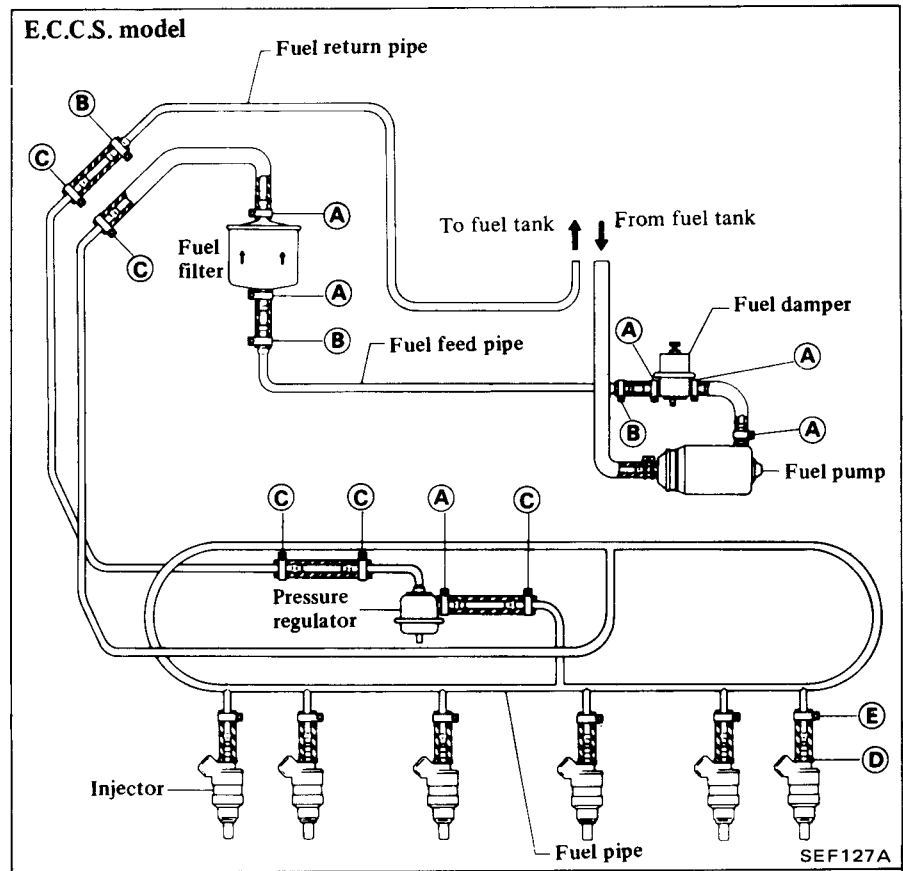
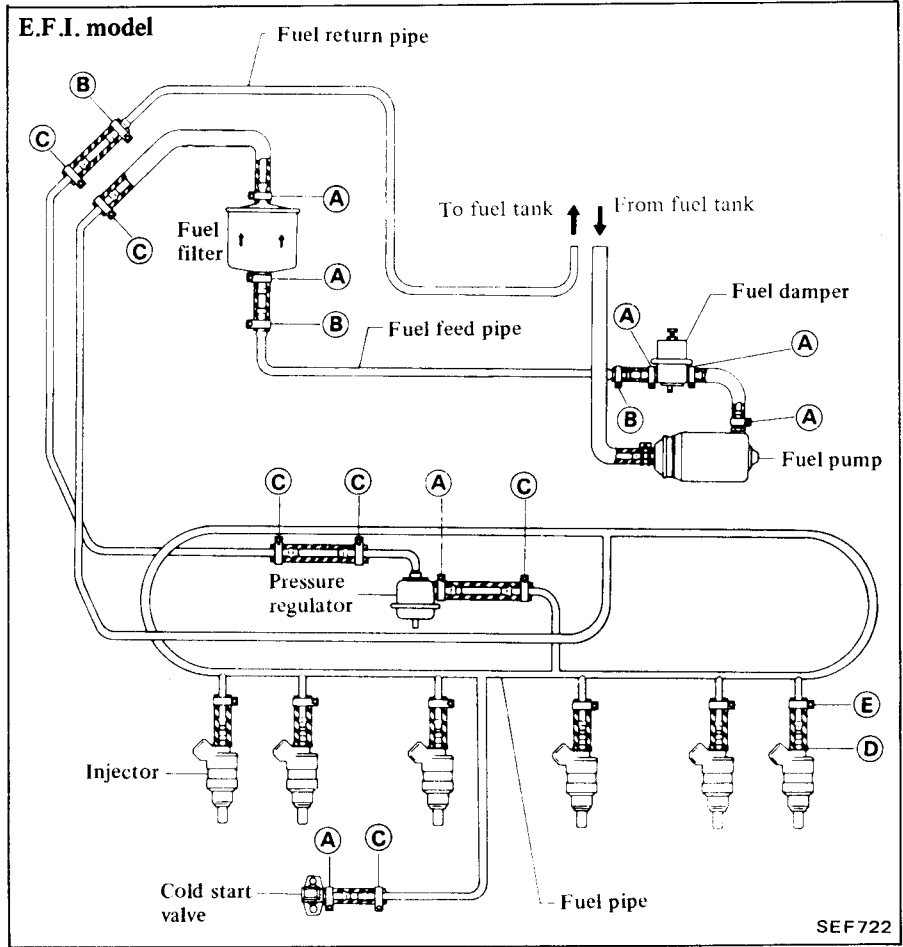

INJECTOR

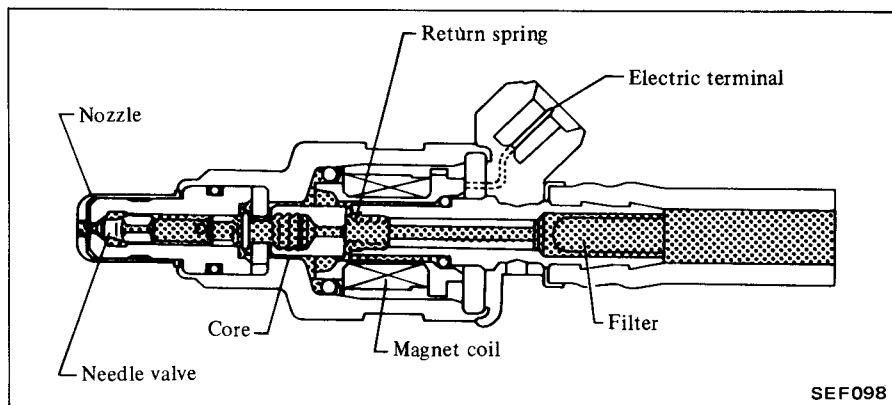

The injector operates on the solenoid valve principle. When an electric signal is applied to the coil built into the injector, the plunger is pulled into the solenoid, thereby opening the needle valve for fuel injection. The quantity of injected fuel is in proportion to the duration of the pulse applied from the control unit.

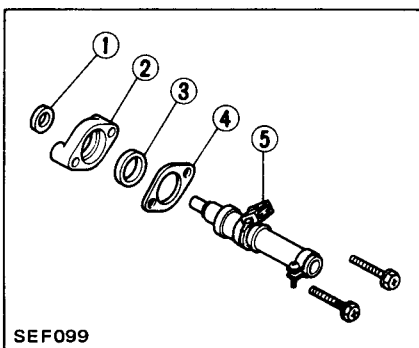

- 1 Injector lower rubber insulator
- 2 Injector lower holder
- 3 Injector upper rubber insulator
- 4 Injector upper holder
- 5 Injector

Inspection

When engine rotates

1. Start the engine and, using a screwdriver, determine whether operating noises can be heard from each injector.

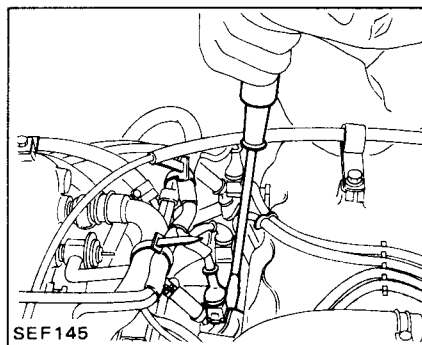

2. Release the idle and air-fuel ratio feedback controls. While the engine is idling, disconnect the injector wiring connectors one by one, beginning with No. 1, to determine whether any changes occur in idling speed or stability.

(1) The injection can be considered faulty if the idle does not change when the connector is disconnected.

(2) If the changes in the idle are even for each cylinder, the injector's operation can be considered normal.

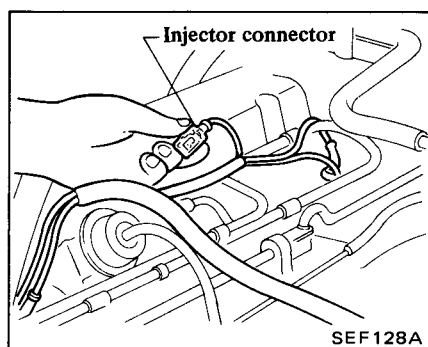

- a. Disconnect the exhaust gas sensor's harness to release the air-fuel ratio feedback control.
- b. To release the idle control, attach a vacuum handy pump to the A.A.C. valve hose, and adjust until the specified idle speed is reached. (E.C.C.S. model only)

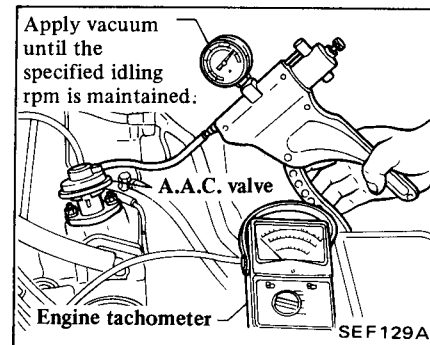

Engine will not start

1. Inspection lamp, as shown in figure below, is required for this test.

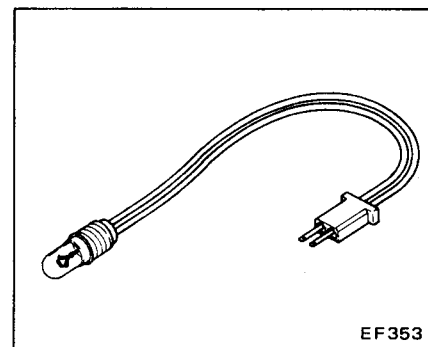

Make inspection lamp as follows:

- 1) Prepare 12V-3W lamp.
 - 2) Prepare socket and set lamp in it.
 - 3) Use flat plate terminals 3 mm (0.12 in) wide, 0.8 mm (0.031 in) thick as male terminals. Place flat plate terminals parallel with each other and keep distance between inside faces 2 mm (0.08 in). Then secure terminals by wrapping insulation tape or with suitable terminal body.
2. Disconnect injector harness connector.

3. Connect inspection lamp to injector harness connector.

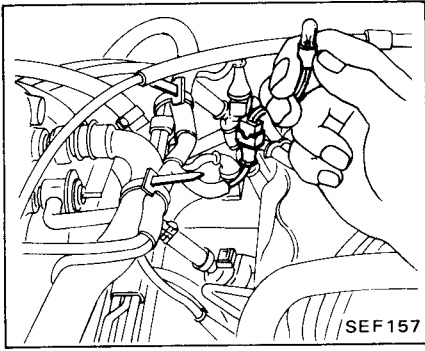

4. After starting engine or cranking engine, check inspection lamp to see if it flashes at regular intervals. If so, electric signals are being properly transmitted to injectors.

- a. The engine should be cranked at a speed of more than 80 rpm.
- b. The control unit may fail to generate a correct pulse signal at an excessively low battery voltage. It is recommended, therefore, that a battery voltage of more than 9 volts be applied during the cranking operation.

5. If the inspection light illuminates, determine whether the electrical resistance between the injector terminals is normal.

Normal value: 2 - 3 ohms

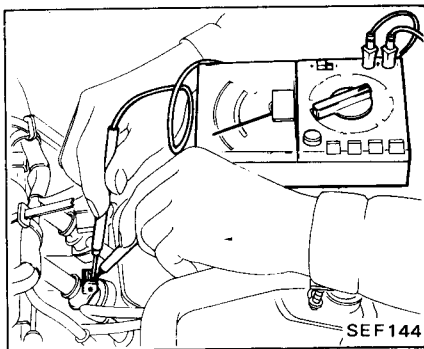

COLD START VALVE

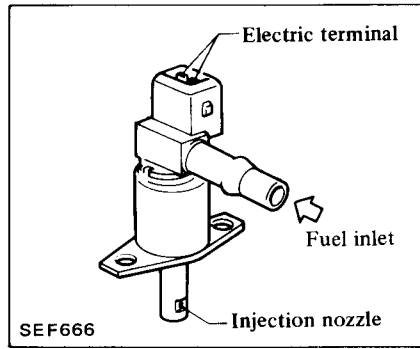

The cold start valve causes fuel to be injected into the intake manifold independently of the injector operation so that the engine can be started smoothly during cold weather.

The cold start valve operates on the electromagnetic principle.

To improve fuel-air mixing at lower temperatures, the cold start valve employs a swirl type nozzle.

AIR FLOW SYSTEM

AIR FLOW METER

The air flow meter measures the quantity of intake air, and sends a signal to the control unit so that the base pulse width can be determined for correct fuel injection by the injector. The air flow meter is provided with a flap in the air passage. As the air flows through the passage, the flap rotates and its angle of rotation electronically signals the control unit.

During idling operation when the amount of intake air is extremely small, the air flows parallel with the flap through the by-pass port so that the specified intake air flow can be provided correctly.

An air temperature sensor is installed in the air passage.

The by-pass port has the air by-pass screw which regulates the idle mixture ratio.

Adjusting the idle mixture should be performed only when it is necessary.

Refer to adjusting the idle mixture.

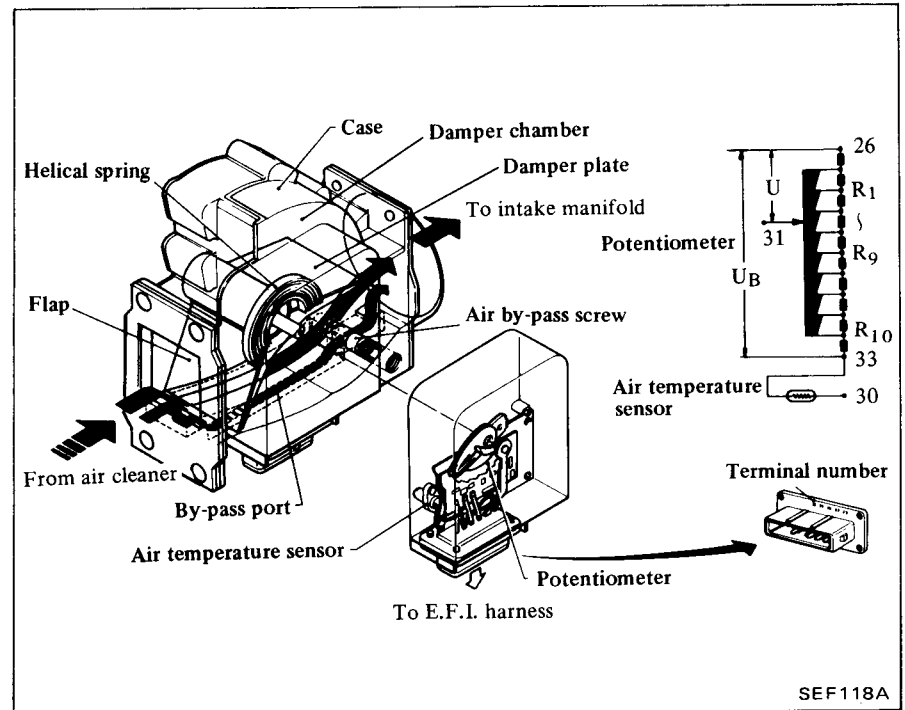

6. If the resistance value is abnormal, replace the injector.

AIR REGULATOR

The air regulator by-passes the throttle valve to control the quantity of air for increasing the engine idling speed when starting the engine at a bimetal temperature of below the specified value.

E.F.I. models 80°C (176°F)
E.C.C.S. models 65°C (149°F)

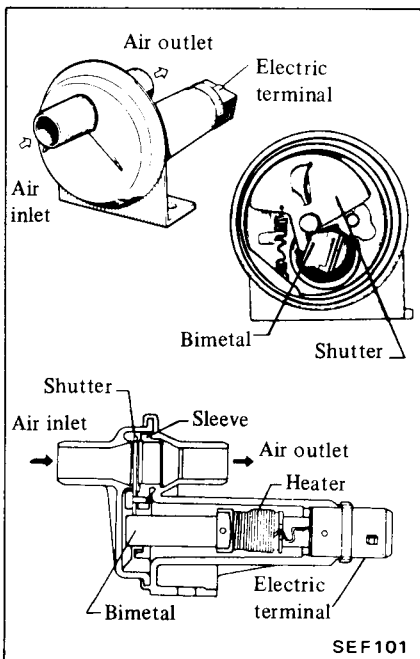

SEF101

A bimetal and a heater are built into the air regulator. When the ignition switch is turned to the "START" position or engine running, electric current flows through the heater, and the bimetal, as it is heated by the heater, begins to move and closes the air passage in a few minutes. The air passage remains closed until the engine is stopped and the bimetal temperature drops to below the specified value.

E.F.I. models 80°C (176°F)
E.C.C.S. models 65°C (149°F)

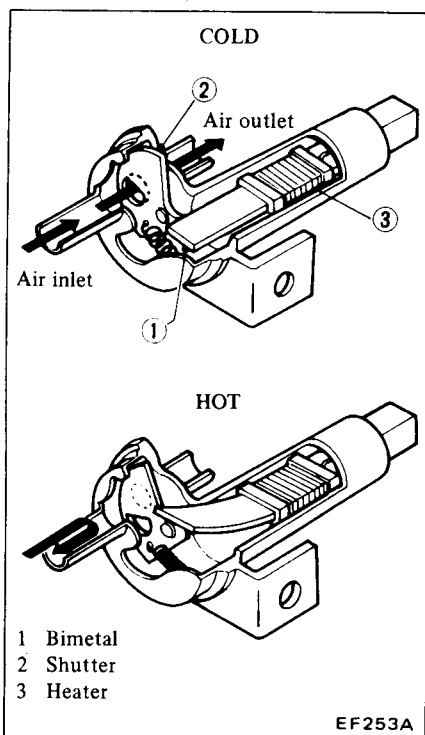

EF253A

THROTTLE CHAMBER

E.F.I. Models

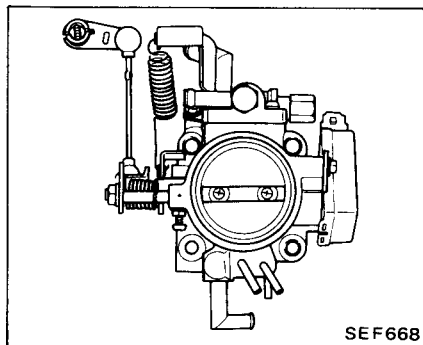

SEF668

E.C.C.S. Models

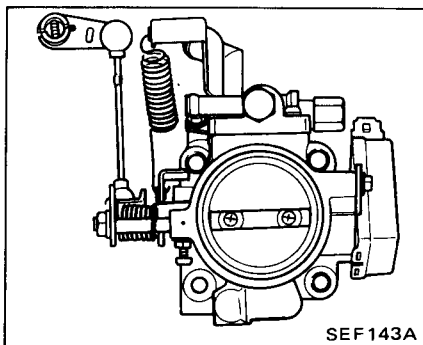

SEF143A

The throttle chamber, located between the air flow meter or the turbo-charger and the intake manifold, is equipped with a valve. This valve controls the intake air flow in response to accelerator pedal movement. The rotary shaft of this valve is connected to the throttle valve switch.

ELECTRICAL SIGNAL SYSTEM

CYLINDER HEAD TEMPERATURE SENSOR

The cylinder head temperature sensor, built into the cylinder head, monitors change in cylinder head temperature and transmits a signal to increase the pulse duration during the warm-up period.

The temperature sensing unit employs a thermistor which is very sensitive in the low temperature range.

The electrical resistance of the thermistor decreases in response to the temperature rise.

AIR TEMPERATURE SENSOR

The air temperature sensor, built into the air flow meter, monitors change in the intake air temperature and transmits a signal for the fuel enrichment to change the pulse duration.

The temperature sensing unit employs a thermistor which is very sensitive in the low temperature range.

The electrical resistance of the thermistor decreases in response to air temperature rise.

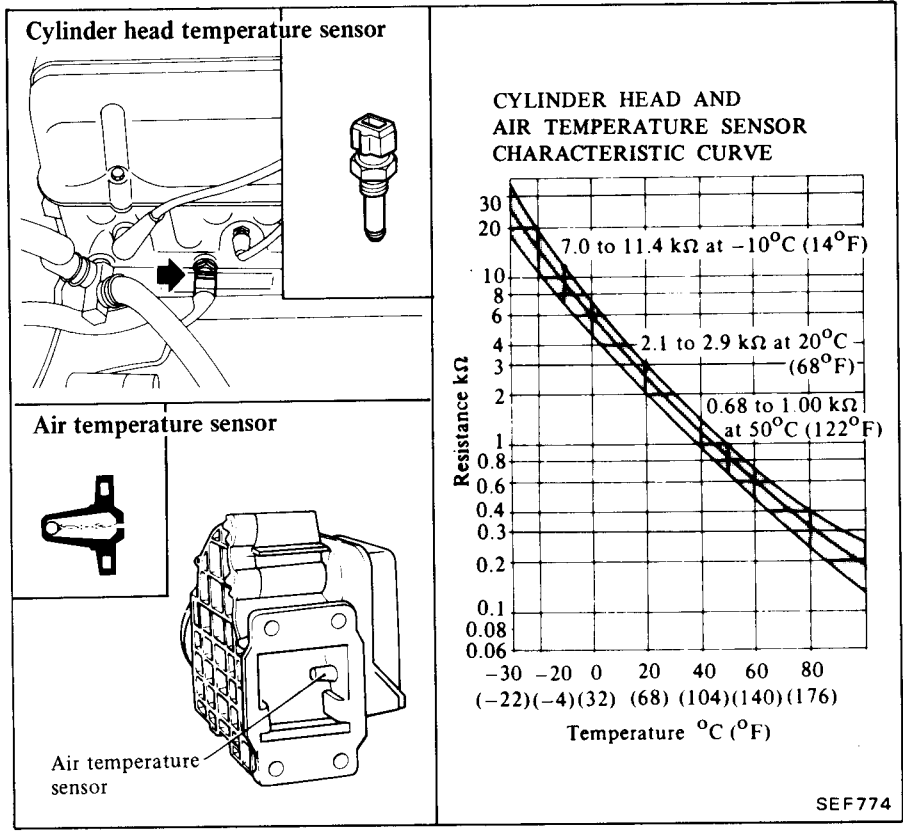

THROTTLE VALVE SWITCH

The throttle valve switch is attached to the throttle chamber and actuates in response to accelerator pedal movement. This switch has two sets of contact points. One set monitors the idle position and the other set monitors full throttle position.

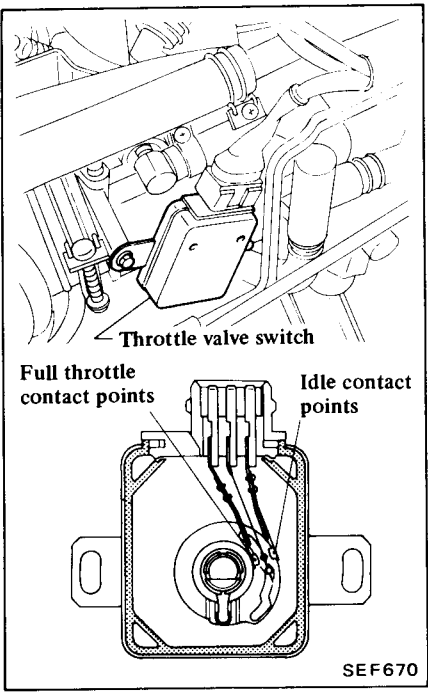

EXHAUST GAS SENSOR

The exhaust gas sensor produces an electromotive force depending on air-fuel mixture ratio.

The electromotive force varies directly with the density of oxygen in exhaust gases which is burned at the theoretically determined air-fuel ratio of the mixture; electromotive force increases when there is a richer mixture, and electromotive force decreases when there is a lean mixture.

The electromotive force is transmitted to the control unit by means of a signal which activates the control unit in order to provide the optimum amount of fuel injection.

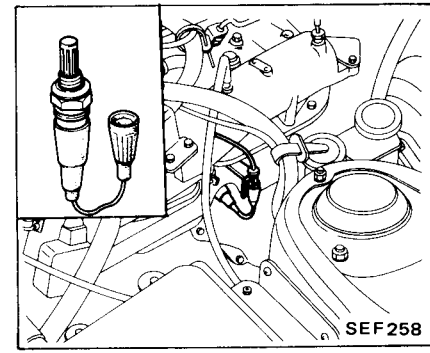

THERMOTIME SWITCH

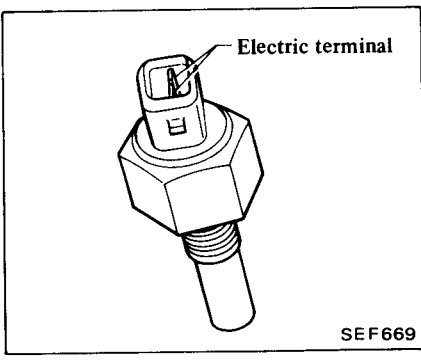

The thermotime switch is built into the thermostat housing.

A harness is connected in series to the cold start valve from the thermotime switch. The bimetal contact in the thermotime switch opens or closes depending on the cooling water temperature, and sends a signal to the cold start valve so that an additional amount of fuel can be injected for starting operation of the engine.

Idle contact

The idle contact closes when the throttle valve is positioned at idle and opens when it is at any other position. The idle contact compensates for after idle enrichment, and sends the fuel shut-off signal.

Full throttle contact

The full throttle contact closes only when the throttle valve is positioned at full throttle (more than 35 degree opening of the throttle valve). The contact is open while the throttle valve is at any other position.

The full contact compensates for enrichment in full throttle.

FUEL SHUT-OFF

Fuel shut-off is accomplished during deceleration when the engine does not require fuel.

The graph below shows the fuel shut off range.

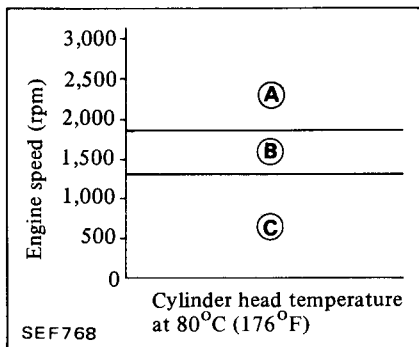

Deceleration from zone "A"	Fuel is shut off; and fuel is injected again in zone "C".
Deceleration from zone "B"	Fuel is shut off; and fuel is injected again in zone "C".
Deceleration from zone "C"	Fuel is not shut off.
Engine rpm increased in order of "C", "B", and "A". (Idle switch ON, downhill driving, etc.)	Fuel is not shut off in zones "C" and "B"; in zone "A", fuel is shut off.

The control unit consists mainly of three integrated circuits formed on the printed circuit board. This construction provides superior control unit reliability.

WARNING:

If your car is equipped with electronic controls, use of a transmitter, such as a radio transmitter (but not a receiver, such as a radio) may interfere with unshielded electronic controls and cause them to malfunction. Car manufacturers do not necessarily use electronic controls in the same ways or for the same operations. Examples of vehicle functions which may involve electronic controls include fuel delivery systems, engine timing, brakes, emission control and cruise control. Definite information regarding the type of electronic controls in your car can only be obtained from the manufacturer. Consult your NISSAN/DATSUN dealer regarding the need for modifications to your car's electronic controls before installation or use of a transmitter.

CONTROL UNIT

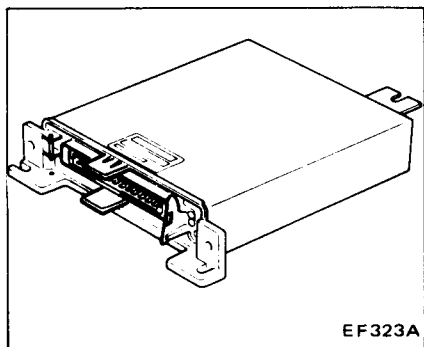

The control unit is connected to the E.F.I. harness by means of a multi-connector, and the E.F.I. harness is connected to other sensors.

The essential role of the control unit is to generate a pulse. Upon receiving an electrical signal from each sensor, the control unit generates a pulse whose duration (injector open-valve time period) is controlled to provide an optimum quantity of fuel according to the engine characteristics.

RELAY

E.F.I. relay

The E.F.I. relay serves to activate the electronic fuel injection system through the ignition switch.

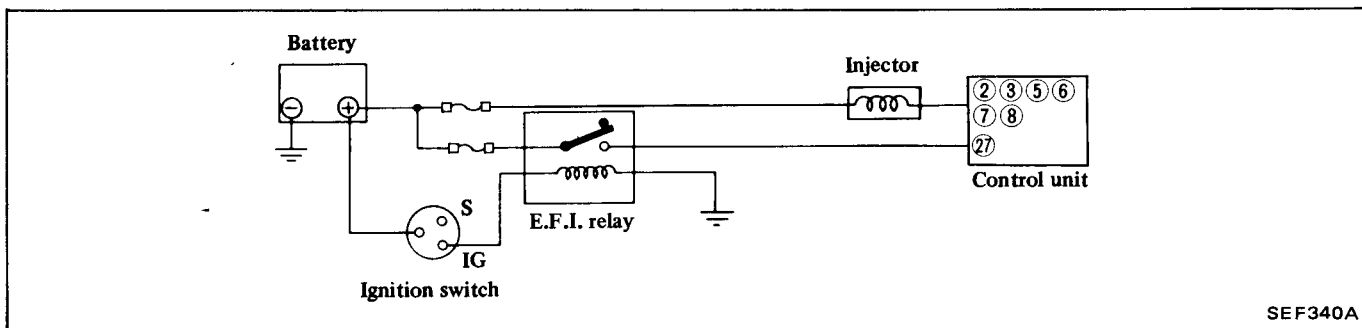

ALTITUDE SWITCH

This switch is attached to the stay on the left side of the instrument panel in the driver's compartment.

Consisting of a bellows and a micro-switch, the switch transmits an ON or OFF signal to the control unit according to change in atmospheric pressure.

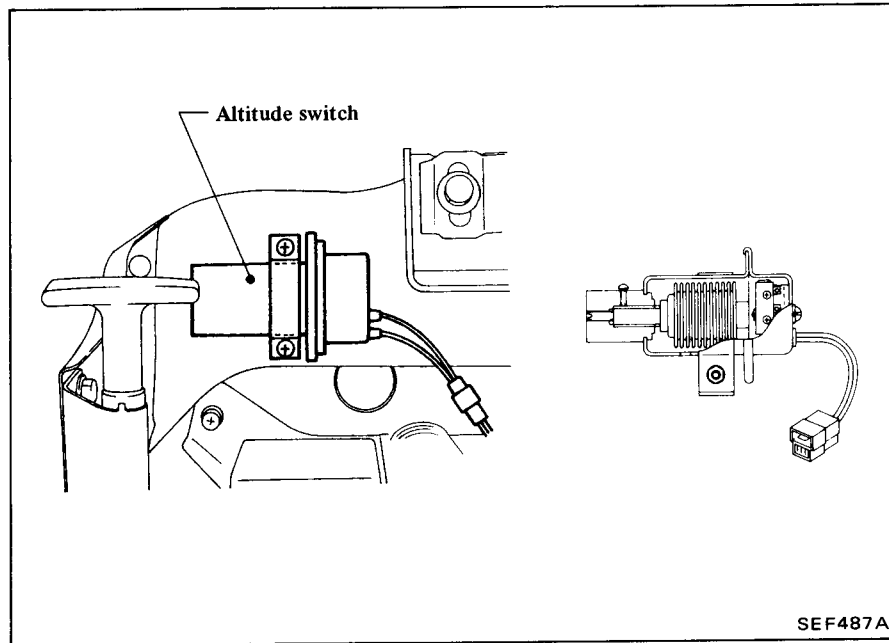

Classification	Atmospheric pressure	Altitude switch
“Low altitude [Approx. 1,370 m (4,500 ft) or lower]	Approx. 86.6 kPa (650 mmHg, 25.59 inHg) or above	OFF
“High” altitude [Approx. 1,370 m (4,500 ft) or higher]	Approx. 86.6 kPa (650 mmHg, 25.59 inHg) or below	ON

FUEL SYSTEM PRESSURE CHECK

Before disconnecting fuel hose, release fuel pressure from fuel line for safety reasons.

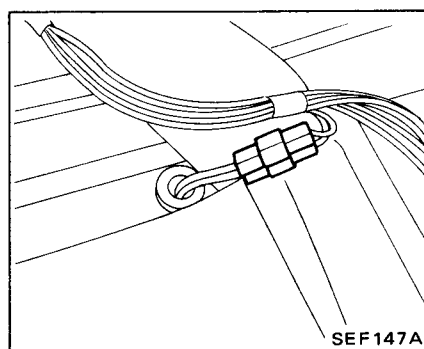

RELEASING FUEL PRESSURE

1. Start the engine.
2. Open back door and remove center tonneau cover.
3. Disconnect fuel pump connector.

4. After the engine stalls, crank the engine two or three times.

5. Turn the ignition switch “OFF”.

6. Connect fuel pump connector.

If engine does not start, remove fuel pump connector and crank the engine for about 5 seconds.

FUEL PRESSURE CHECK

When reconnecting the lines, always use new clamps and be sure to position them correctly.

Use a torque driver to tighten clamps.

1. Install Pressure Gauge (J 25400-34) between fuel filter hose and metal pipe at point shown. For convenience in later tests, position gauge so that it can be read from driver's seat.

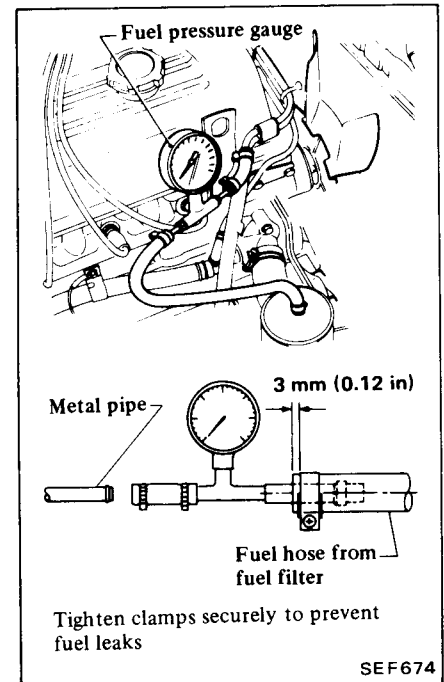

2. Start engine and read fuel pressure gauge.

At idling:

Approximately 206 kPa (2.1 kg/cm², 30 psi)

The moment accelerator pedal is fully depressed:

Approximately 255 kPa (2.6 kg/cm², 37 psi)

3. If fuel pressure is not as specified, replace pressure regulator, and repeat fuel pressure check.

If below the specified value, check for clogged or deformed fuel lines, and if necessary, replace fuel pump as an assembly or check valve.

4. Connect variable vacuum source, J 23738 or equivalent to fuel regulator. Disconnect fuel pressure regulator

vacuum hose from intake manifold and attach hose to variable vacuum source.

5. Disconnect fuel pump connector and apply battery voltage when checking the following.

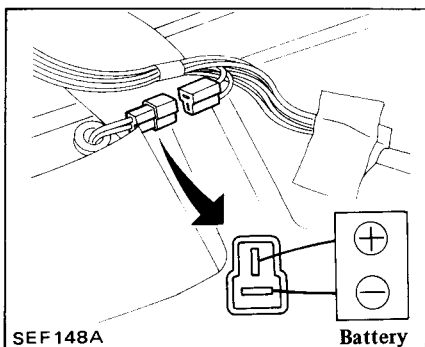

6. Observe fuel pressure readings as vacuum is changed.

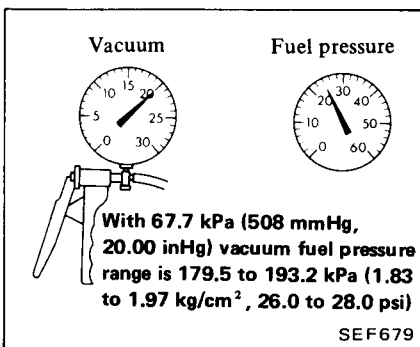
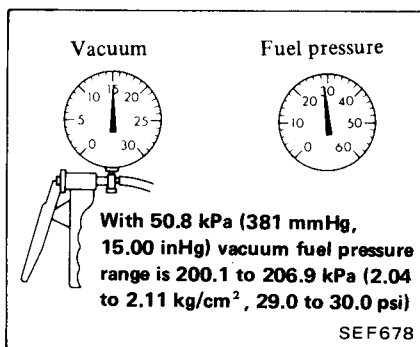
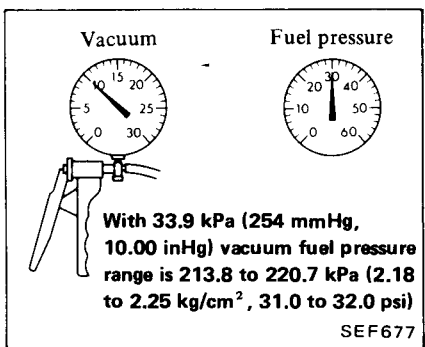
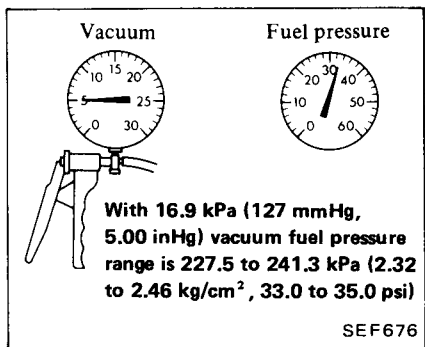
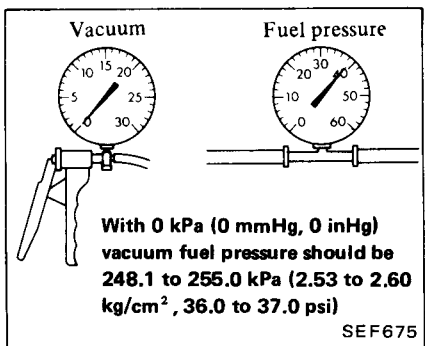

Fuel pressure must decrease as vacuum increases. If results are unsatisfactory, replace pressure regulator.

7. Reconnect fuel pump connector.
8. Disconnect variable vacuum source and connect fuel pressure regulator vacuum hose to intake manifold.

REPLACEMENT

1. Lower fuel pressure. Refer to FUEL PRESSURE CHECK.
2. Disconnect electric connector from injector.
3. Disengage harness from fuel pipe wire clamp.
4. Disconnect blow-by hose at rocker cover side.
5. Disconnect vacuum tube (connecting pressure regulator to intake manifold) from pressure regulator.
6. Remove air regulator pipe.
7. Disconnect fuel feed hose and fuel return hose from fuel pipe.

Place a rag under fuel pipe to prevent splashing of fuel.

8. Remove bolts securing fuel pipe.

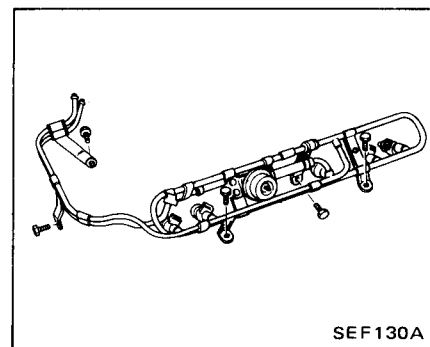

9. Remove screws securing fuel injectors.

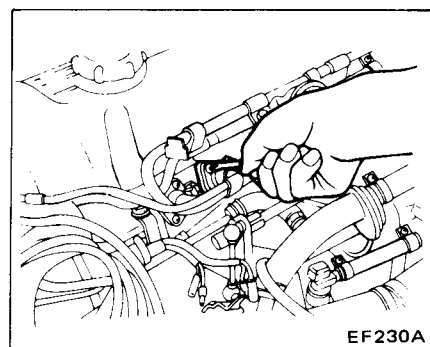

10. Remove fuel pipe assembly by pulling out fuel pipe, injector and pressure regulator as an assembly.

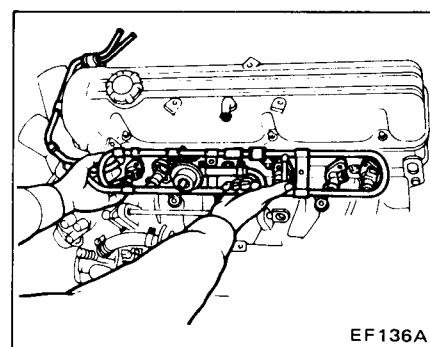

11. Unfasten hose clamp on fuel injector and remove fuel injector from fuel pipe.

Place a rag under injector when disconnecting fuel pipe to prevent splashing of fuel.

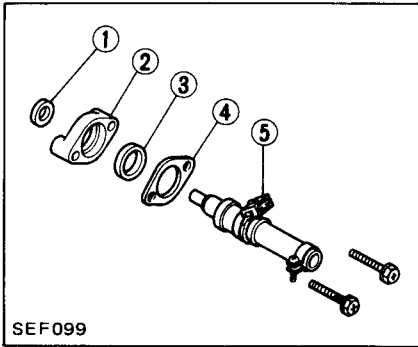

- 1 Injector lower rubber insulator
- 2 Injector lower holder
- 3 Injector upper rubber insulator
- 4 Injector upper holder
- 5 Injector

12. To install injector and fuel pipe, reverse the order of removal.

When installing injector, check that there are no scratches or abrasion at lower rubber insulator, and securely install it, making sure it is air-tight.

13. For installation of fuel hose, refer to Fuel Hose.

INJECTOR RUBBER HOSE

If necessary, replace injector rubber hose. Proceed as follows:

Removal

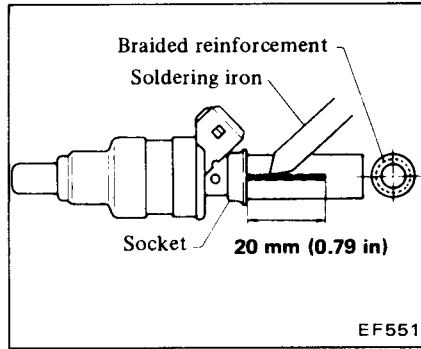

1. On injector rubber hose, measure off a point approx. 20 mm (0.79 in) from socket end.
2. Heat soldering iron (150 watt) for 15 minutes. Cut hose into braided reinforcement from mark to socket end.

Do not feed soldering iron until it touches injector tail piece.

CAUTION:

- a. Be careful not to damage socket, plastic connector, etc. with soldering iron.
- b. Never place injector in a vise when disconnecting rubber hose.

3. Then pull rubber hose out with hand.

Installation

1. Clean exterior of injector tail piece.
2. Wet inside of new rubber hose with fuel.
3. Push end of rubber hose with hose socket onto injector tail piece by hand as far as they will go.

Clamp is not necessary at this connection.

CAUTION:

After properly connecting fuel hose to injector, check connection for fuel leakage.

ELECTRONIC CONCENTRATED ENGINE CONTROL SYSTEM (E.C.C.S.)

OUTLINE

In the Electronic Concentrated Engine Control System (E.C.C.S.), the control unit employs a micro-computer. This micro-computer controls fuel injection, spark timing, exhaust gas recirculation (E.G.R.), idle speed, fuel pump operation and mixture ratio feedback.

It is unnecessary to adjust idle CO%, idle rpm and ignition timing.

Electrical signals from each sensor are fed into the micro-computer and each actuator is controlled by an electrical pulse with a duration that is computed in the micro-computer.

E.C.C.S. CONTROL UNIT

The E.C.C.S. control unit consists of a micro-computer, connectors for signal input and output and power supply, and an exhaust gas sensor monitor lamp. The control unit controls the quantity of fuel that is injected, ignition timing, idle speed, E.G.R. quantity, fuel pump operation, and feedback of the mixture ratio.

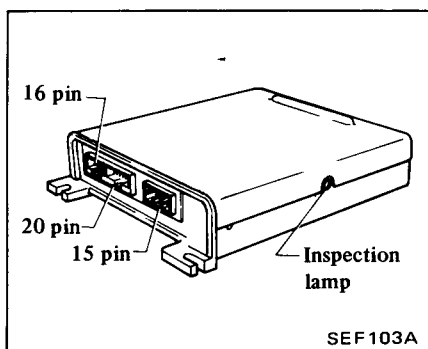

WARNING:

If your car is equipped with electronic controls, use of a transmitter, such as a radio transmitter (but not a receiver, such as a radio) may interfere with unshielded electronic controls and cause them to malfunction. Car manufacturers do not necessarily use electronic controls in the same ways or for the same operations. Examples of vehicle functions which may involve electronic controls include fuel delivery systems, engine timing, brakes, emission control and cruise control. Definite information regarding the type of electronic controls in your car can only be obtained from the manufacturer. Consult your NISSAN/DATSUN dealer regarding the need for modifications to your car's electronic controls before installation or use of a transmitter.

CRANK ANGLE SENSOR

The crank angle sensor detects engine rpms and the crank angle (piston position). It also sends a signal to the control unit to control various operations. This sensor is built into the distributor.

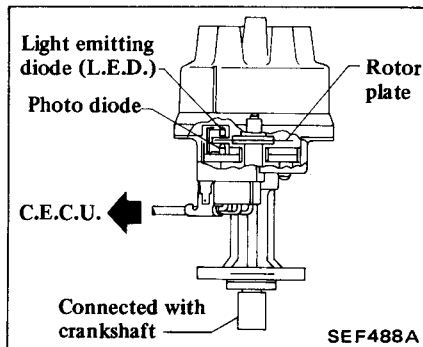

Use care when installing, the crank sensor built in to the distributor as the position of matching mark is different from former model. (Refer to Section EM.)

SIGNAL ROTOR PLATE

The signal rotor plate has 360 slits at 1° intervals on its outer periphery. It also has six slits at 60° intervals.

These six slits are used to detect the crank angle, that is, the position of each piston. The teeth are used to provide the 1° signal that is necessary to control engine rpms and ignition timing.

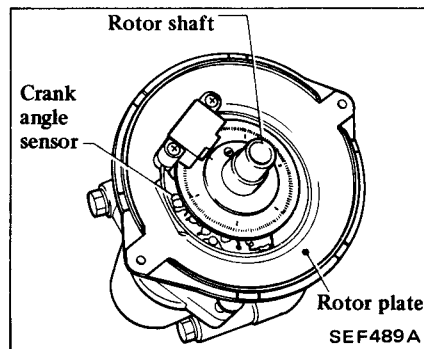

CRANK ANGLE SENSOR OPERATION

The crank angle sensor has two diodes and a wave forming circuit. When a signal rotor plate passes the space between the Light Emitting Diode (L.E.D.) and Photo Diode, the slit of the signal rotor plate alternately cuts the light which is sent to the photo diode from the L.E.D. This causes an alternative voltage and it is then converted into an on-off pulse by the wave forming circuit, which is sent to the control unit.

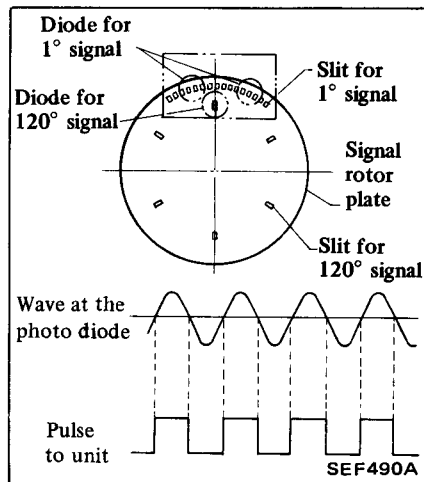

Detection of 1° signal (For detecting of engine rpms and ignition timing control)

Diodes ① and ③ are used to detect the 1° signal which is created by 360 slits on the rotor plate. When a slit reaches the space between the L.E.D. and photo diode, the photo diode receives the light from the L.E.D. and this causes an alternative voltage. Thus, each wave from each diode is compounded. Then, the compound wave is converted into an on-off pulse. This 1° on-off signal is sent to the control unit.

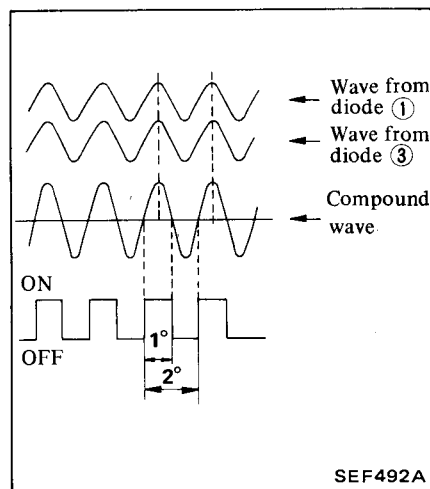
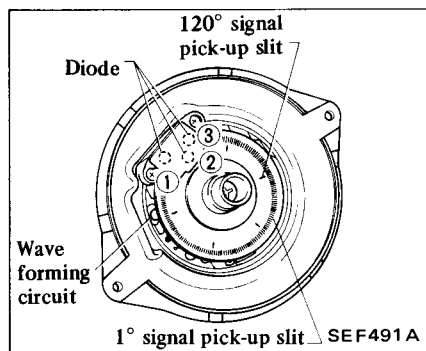

Detection of 120° signal (For detecting piston T.D.C.)

Diode ② is used to detect the 120° signal which is created by 60° slits on the rotor plate. When a slit reaches the space between the L.E.D. and photo diode, the photo diode catches the light from the L.E.D. and this causes an alternative voltage. At this time, a signal on-off pulse is generated. Since engine rpm is twice that of the distributor, the rotor plate has six dits at 60° intervals.

THROTTLE VALVE SWITCH

The throttle valve switch is attached to the throttle chamber and actuates in response to accelerator pedal movement.

This switch has the idle contact. The idle contact closes when the throttle valve is positioned at idle and opens when it is at any other position.

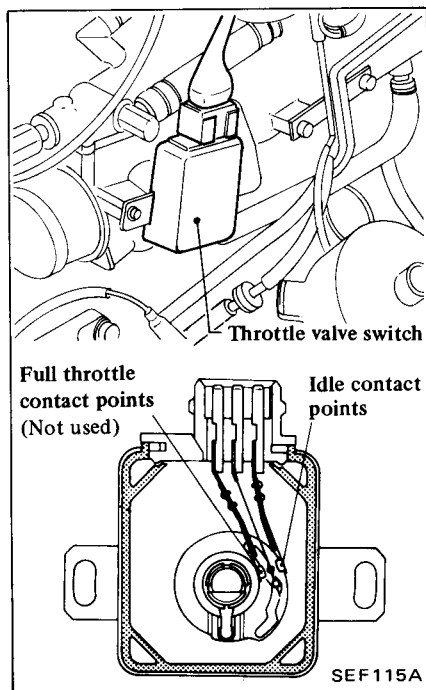

ADJUSTMENT

Ohmmeter method

1. Disconnect throttle valve switch connector.
2. Connect ohmmeter between terminals ⑱ and ㉓, and make sure continuity exists.

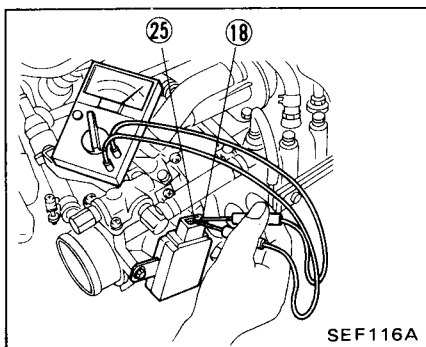

3. Adjust throttle valve switch position, with retaining screw, so that idle switch may be changed from "ON" to "OFF" when engine speed is about 750 rpm under no load.

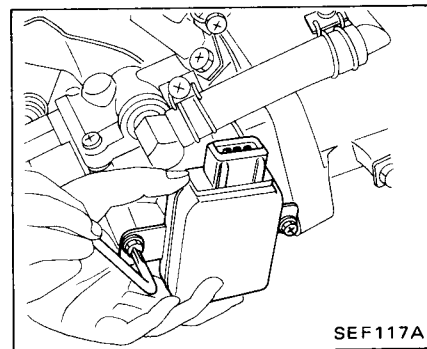

AIR FLOW METER

Refer to E.F.I. system operation.

CYLINDER HEAD TEMPERATURE SENSOR

Refer to E.F.I. system operation.

AIR TEMPERATURE SENSOR

Refer to E.F.I. system operation.

BAROMETRIC PRESSURE SENSOR

This sensor is built into the control unit and senses the barometric pressure in order to compensate for the density of the intake air.

This sensor cannot be replaced, adjusted or checked as a single unit.

If it malfunctions, replace control unit.

EXHAUST GAS SENSOR

The exhaust gas sensor, which is built into the exhaust manifold, monitors the density of oxygen in the exhaust gas. It consists of a closed-end tube made of ceramic zirconia and other components. Porous platinum electrodes cover the tubes inner and outer surfaces. The closed-end of the tube is exposed to the exhaust gas in the exhaust manifold. The tubes outer surface contacts the exhaust gas while the inner surface contacts the air.

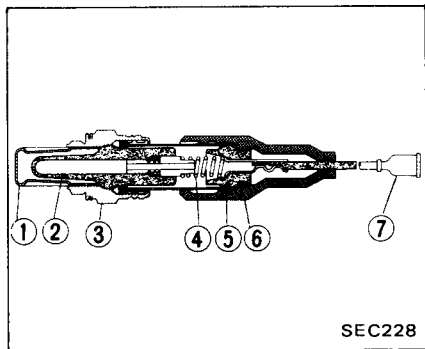

- | | |
|-----------------|--------------------|
| 1 Louver | 5 Terminal support |
| 2 Zirconia tube | 6 Boots |
| 3 Holder | 7 Connector |
| 4 Spring | |

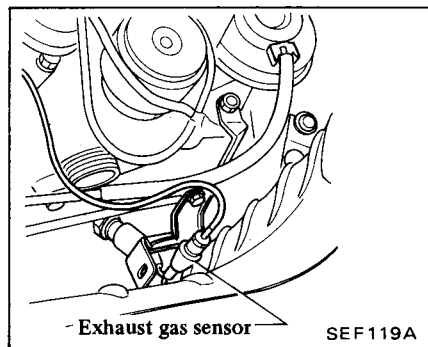

DETONATION SENSOR

The detonation sensor is attached to the cylinder block and senses engine knocking conditions. The sensor monitors the knocking from each combustion chamber and sends an electric signal to the control unit where it is changed to a knocking signal.

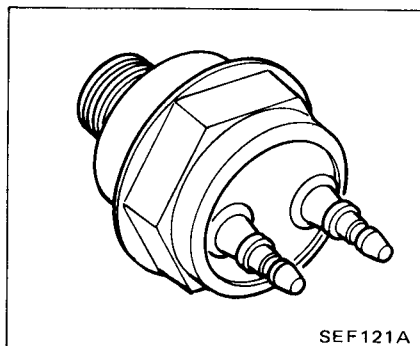
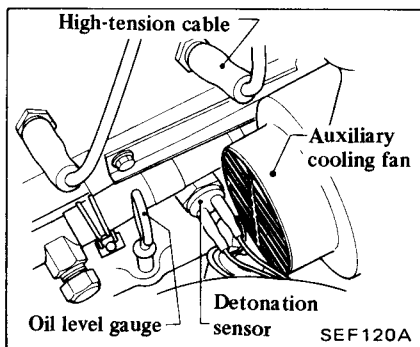

PARK/NEUTRAL SWITCH

The park/neutral switch detects the transmission gear selector's position and transmits an electric signal to the control unit.

CAR SPEED SENSOR

The car speed sensor provides a car speed signal to the control unit.

The speed sensor consists of a reed switch, which is installed in the speed meter unit and transforms car speed into a pulse signal.

BATTERY VOLTAGE

Battery voltage is sent to the control unit, which then function to compensate the variability in it.

FUEL INJECTION CONTROL

There are two ways to control fuel injection: open-loop control and

closed-loop control. Which one is used depends on the cylinder head tempera-

ture, engine rpm, engine load, exhaust gas sensor signal and so forth.

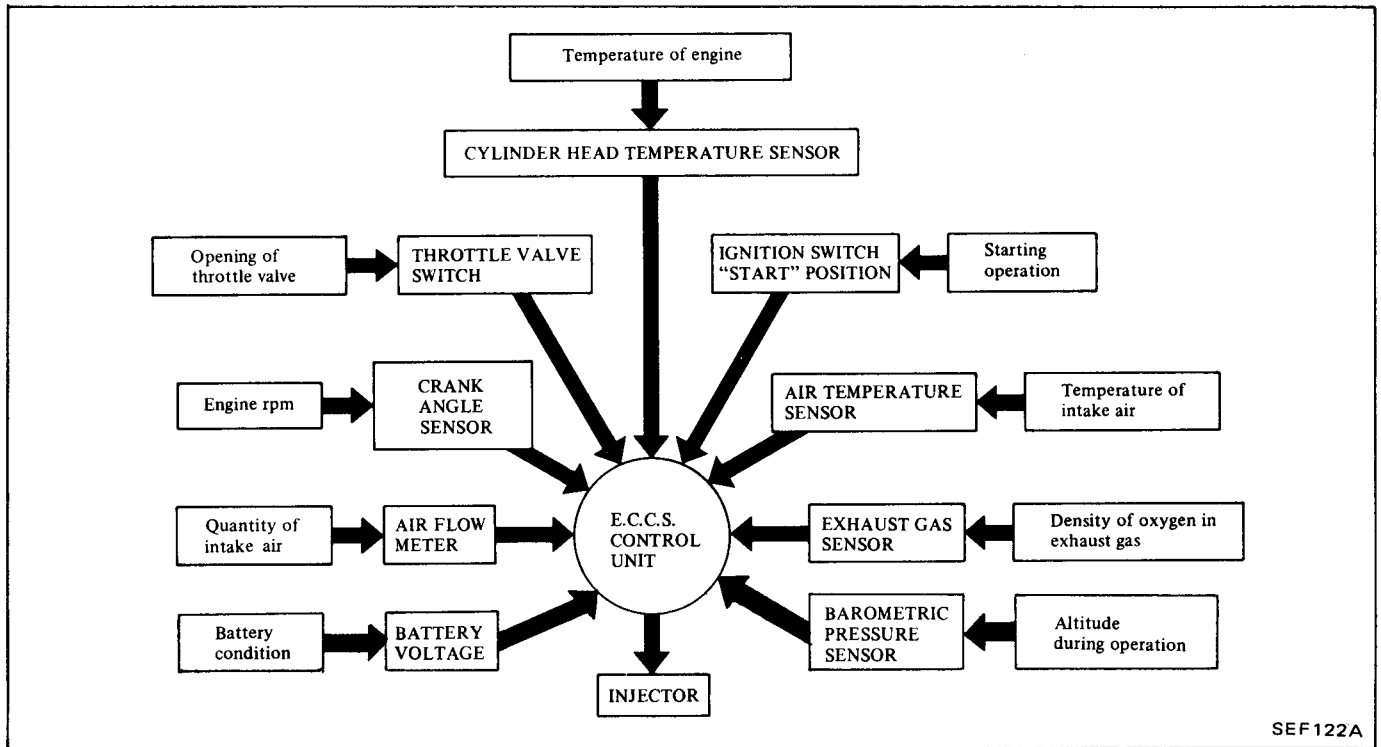

The control unit determines the proper quantity of fuel to be injected from each signal input and then operates the injector. Injections are timed for each rotation of the engine by the crank angle sensor signal and are made simultaneously in every cylinder.

OPEN-LOOP CONTROL

For improved driveability, fuel injection is controlled by open-loop control when the engine is cold, when driving at high speeds or under heavy load and when the fuel shut-off system is in operation. With open-loop control, the mixture ratio is determined by the Central Electronic Control Unit (C.E.C.U.) to correspond to the engine rpm, engine load and engine warm-up conditions.

Open-loop control will activate under the following conditions:

In the following instances, the control unit emits a signal that will return mixture ratio to the best point which will keep a good driving condition.

Starting engine

When starting engine.

Cold engine

Cylinder head temperature is below 40°C (104°F).

Driving condition

When driving at high speeds (about 3,600 rpm) or under heavy load.

Exhaust gas sensor time monitor

- When an exhaust gas sensor monitors a too rich condition for more than 6.4 seconds.
- When an exhaust gas sensor monitors a too lean condition for more than 10 seconds.

Fuel shut-off operation

Fuel shut-off is accomplished during deceleration when the engine does not require fuel.

The graph below shows the fuel shut off range.

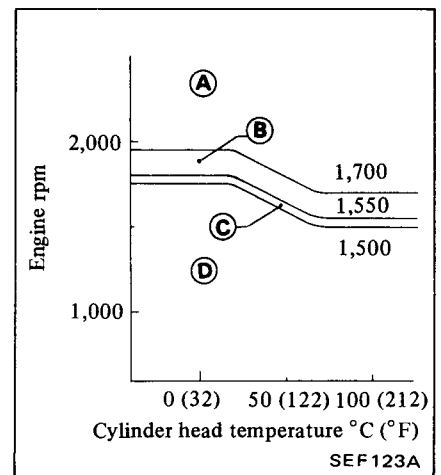

When a transmission gear is in "N" or "P" (A/T) and "Neutral" (M/T) position, or a clutch is depressed, this system does not operate.

Deceleration from zone “(A)”	Fuel is shut off; and fuel is injected again in zone “(D)”.
Deceleration from zone “(B)”	Fuel is shut off; and fuel is injected again in zone “(D)”.
Deceleration from zone “(C)” and “(D)”	Fuel is not shut off.
Engine rpm increased in the order of “(D)”, “(C)”, “(B)” and “(A)”. (Idle switch ON, downhill driving, etc.)	Fuel is not shut off in zones “(D)”, “(C)” and “(B)”; in zone “(A)”, fuel is shut off.

neously. The system uses the oxygen sensor located in the exhaust manifold to give an indication of whether the inlet mixture ratio is richer or leaner than the stoichiometric point. The sensor transmits a nonlinear voltage to the electronic control unit. The control unit adjusts the injection pulse width according to the sensor voltage so the mixture ratio will be within the narrow window of the three-way catalyst. During engine warm-up period, however, this system becomes open until the sensor reaches the operating temperature.

MIXTURE RATIO FEEDBACK CONTROL (Closed-loop control)

This system is designed to control

the mixture ratio precisely to the stoichiometric point so that the three-way catalyst can minimize CO, HC and NOx emissions simulta-

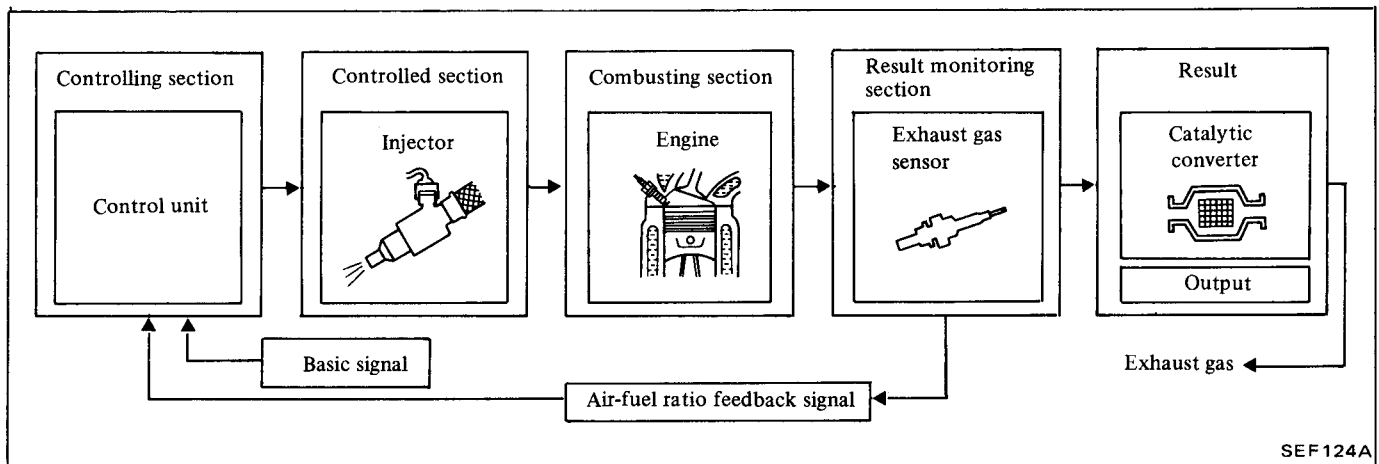

FUEL PUMP CONTROL

The fuel pump is controlled by the central electronic control unit adjusting to the engine conditions. The signals from engine crank angle and ignition switch are used for the fuel pump operation.

FUEL PUMP

A relief valve in the pump is designed to open when the pressure in the fuel line rises over 422 to 490 kPa (4.3 to 5.0 kg/cm², 61 to 71 psi) due to malfunction in the pressure system.

The check valve prevents abrupt drop of pressure in the fuel pipe when stopping the engine.

FUEL PUMP ELECTRICAL CIRCUIT

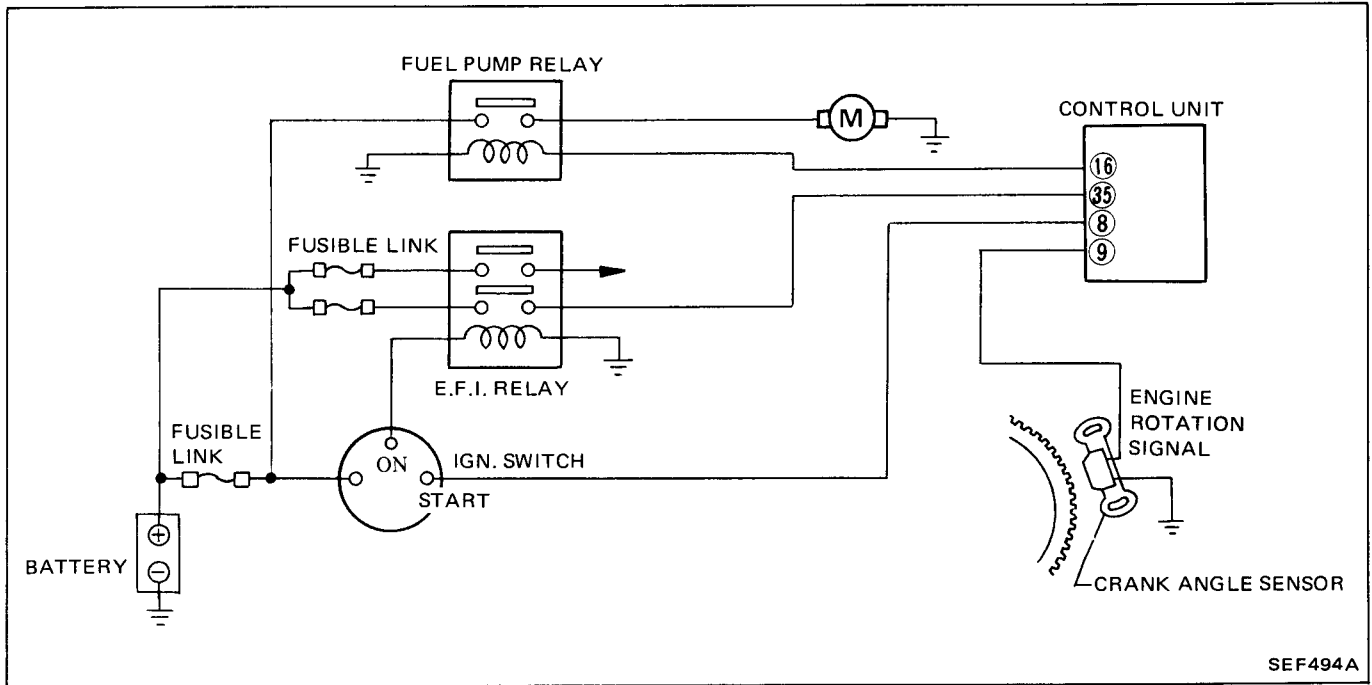

SEF494A

Fuel pump operation

Ignition switch position	Fuel pump operation	Engine speed	Crank angle sensor signal (received by control unit)	Fuel pump relay state
ON	Operates for 5 seconds	Stops	120° signal: None	ON for 5 seconds
START	Stops	Below 20 rpm	120° signal: None for 1 second	OFF
	Operates	Above 20 rpm	120° signal: Provided in 1 second	ON
ON	Stops	Below 20 rpm	120° signal: None for 1 second	OFF
	Operates	Above 20 rpm	120° signal: Provided in 1 second	ON

FUEL PUMP CONTROL MODULATOR

This modulator monitors engine conditions (engine rpm, cylinder head temperature, injector operating pulse width, etc.) and controls the voltage supplied to fuel pump. As a result of this operation, the fuel pump operation is controlled in order to reduce fuel pump noise and the power consumption of the fuel pump.

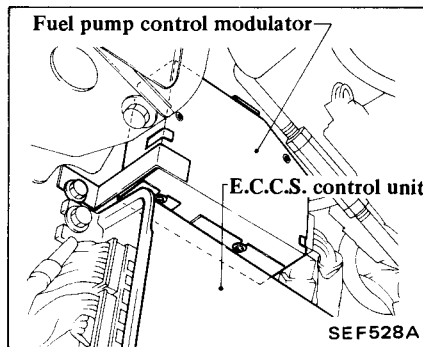

SEF528A

Operating circuit

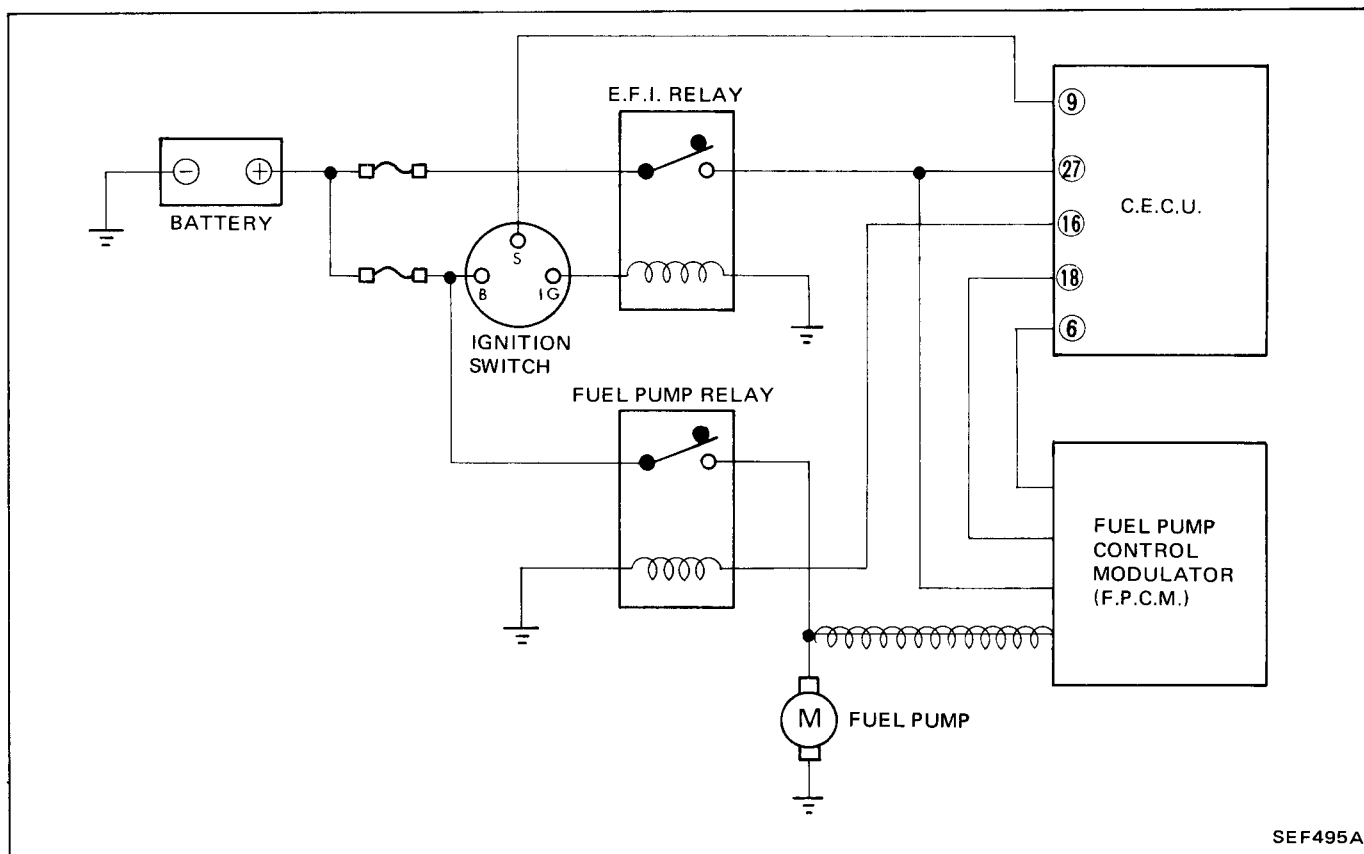

Operation

Engine operating condition	Voltage supplied to fuel pump
Engine cranking	Battery voltage
Above engine speed of 3,200 rpm	
Above injector operating pulse width of 3.5 m sec	
Above cylinder head temperature of 100°C (212°F)	
Below battery voltage of 9.8V	9.8 V
Except the above conditions	

For other part descriptions and inspections, and fuel pressure check for Fuel Flow System, see E.F.I. System Operation. -

ELECTRONIC IGNITION TIMING CONTROL

The ignition timing is controlled by the central electronic control unit adjusting to the engine operating conditions: that is, as the best ignition timing in each driving condition has been memorized in the unit, the ignition timing is determined by the electric signal calculated in the unit.

The signals used for the determination of ignition timing are cylinder head temperature, engine rpm, engine load, engine crank angle, detonation sensor and so forth.

Then, the signal from the central electronic control unit is transmitted to the power transistor of the ignition coil, and controls the ignition timing. If there is engine knocking, a detonation sensor monitors its condition and the signal is transmitted to the central electronic control unit. After receiving it, the control unit controls the ignition timing to avoid the knocking condition.

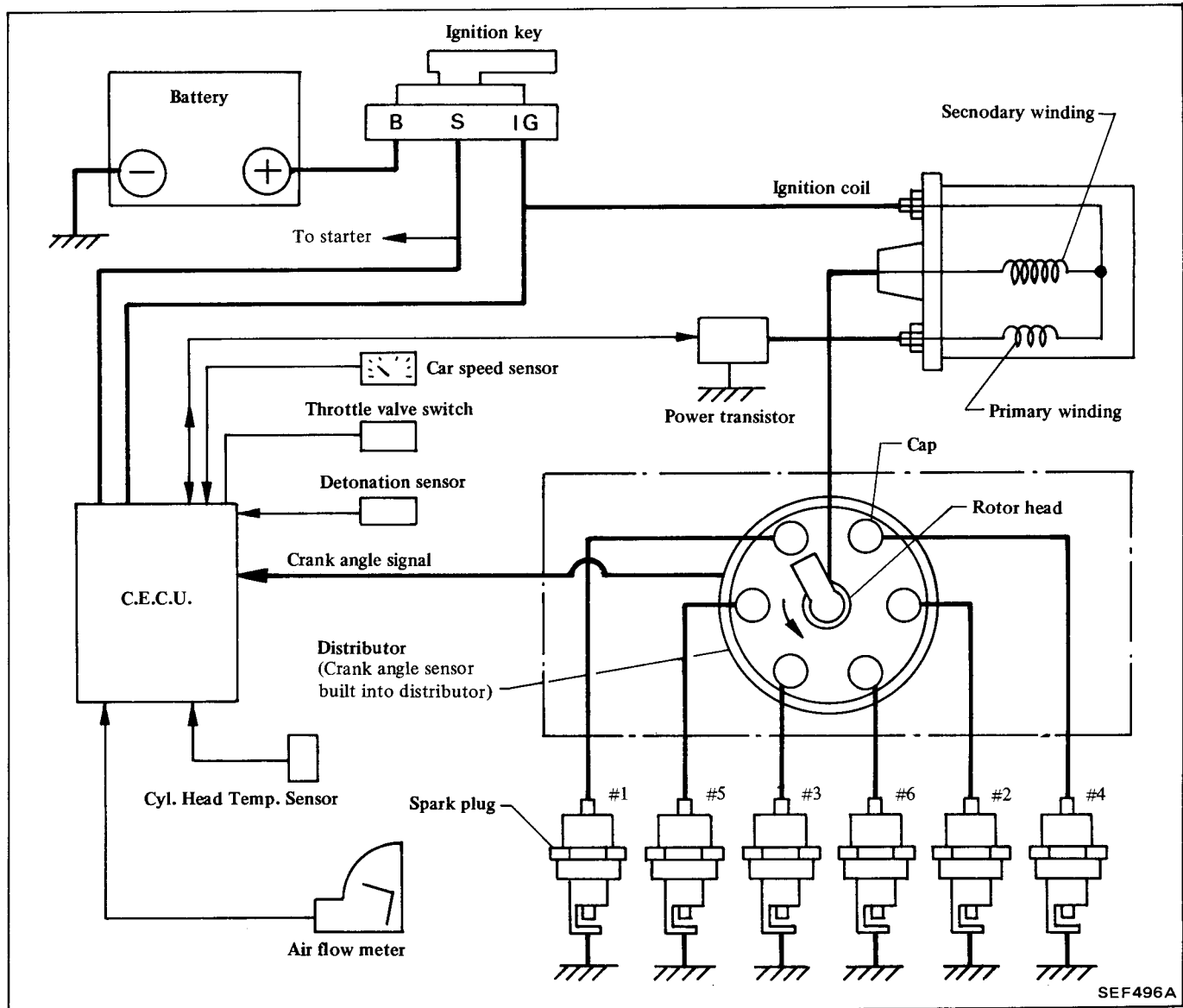

SEF496A

ADJUSTMENT

Ignition timing is automatically controlled by the control unit, and it is usually unnecessary to adjust it. However, the ignition timing can go wrong if the crank angle sensor mounting position gets out of alignment. When this happens, the crank angle sensor must be adjusted.

IGNITION COIL

The ignition coil has a built-in power transistor. The signal from the control unit is amplified by the power transistor. This amplified signal is used to connect and disconnect the ignition coil's primary current to generate high voltage across the secondary coil, and

thereby create a spark in the spark plug.

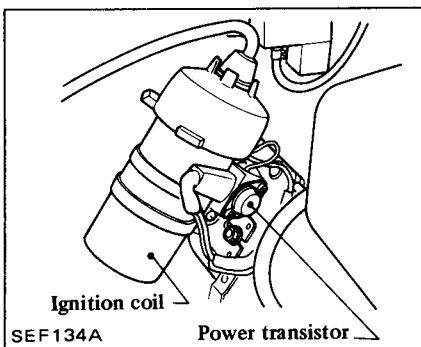

SEF134A

DETONATION SENSOR

The detonation sensor is installed in the side face of the cylinder block. It converts the vibrations caused by

pressure in the combustion chamber into electrical signals. If the engine knocks while operating, the abnormal vibration will be detected by the detonation sensor. This signal is then sent to the control unit to retard the ignition timing to prevent further knocking.

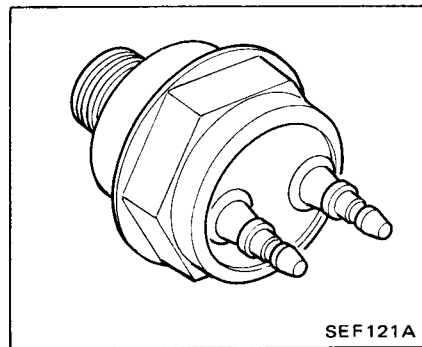

SEF121A

EXHAUST GAS RECIRCULATION (E.G.R.) CONTROL

E.G.R. is controlled by the central electronic control unit adjusting to the

engine operating conditions.

Cylinder head temperature, engine rpm, engine load, air temperature and barometric pressure are used for the determination of the E.G.R. amount.

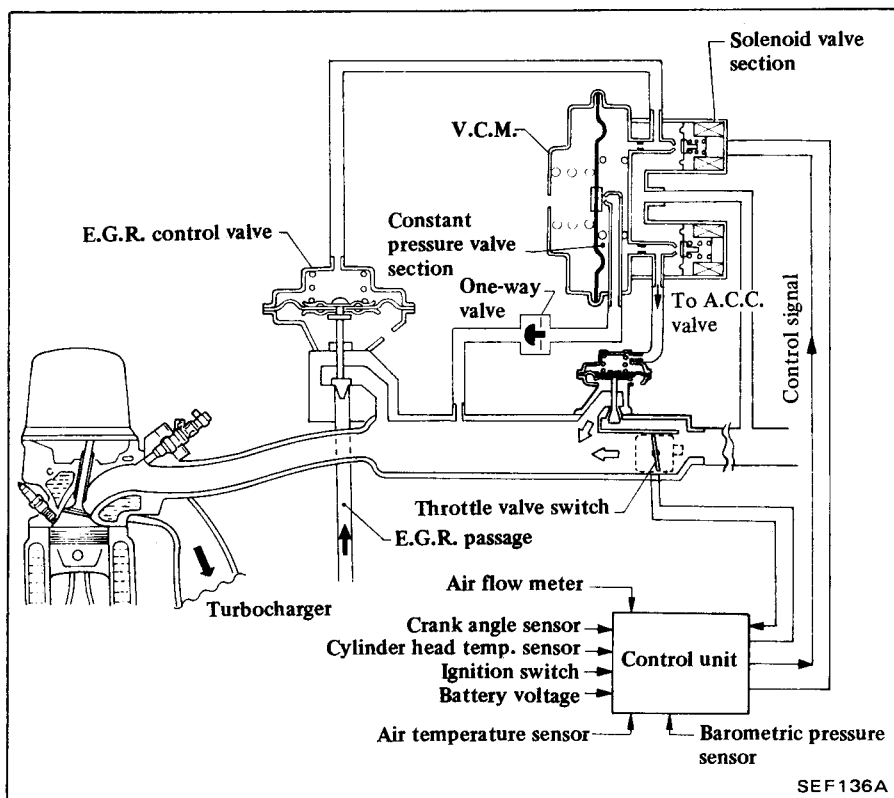

These signals are transmitted to the control unit where optimum E.G.R. quantities are recorded. To obtain the optimum E.G.R. quantity that corresponds to the engine operating conditions at the time, an electric signal is

sent to the vacuum control modulator (V.C.M.). The vacuum control modulator transforms the electric signal to a vacuum signal, which in turn controls the E.G.R. valve.

OPERATION

Cylinder head temperature °C (°F)	Throttle valve switch	Starter switch	V.C.M. valve solenoid valve	E.G.R. control valve	E.G.R.
Below 57 (135)	ON	ON	ON	Closed	Not actuated
	OFF	OFF			
57 - 115 (135 - 239)	ON	ON	ON	Closed	Not actuated
	OFF	OFF	ON-OFF (control vacuum)	Open	Actuated
Above 115 (239)	ON	ON	ON	Closed	Not actuated
	OFF	OFF			

VACUUM CONTROL MODULATOR (V.C.M.)

The vacuum control modulator is composed of a pressure regulator and solenoid valve. Intake manifold vacuum is used as the vacuum source for the pressure regulator. The passage leading to the atmosphere is controlled by solenoid valves. Using these components, the vacuum control modulator provides vacuum to the E.G.R. valve and A.C.C. valve (for idle speed control) following the electric signal from the control unit.

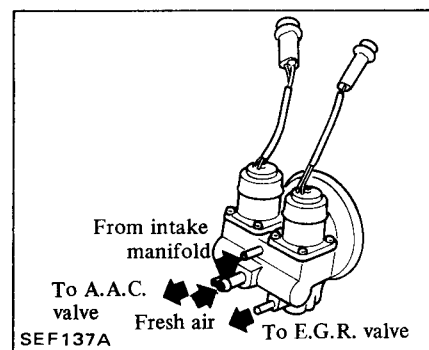

ONE-WAY VALVE

The one-way valve is utilized for the purpose of preventing the V.C.M. from applying positive pressure in high speed conditions.

This valve is installed in the vacuum line leading to V.C.M.

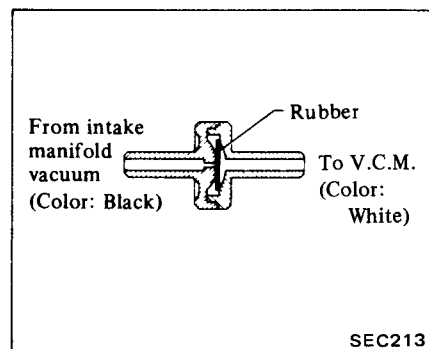

Operation

If the intake manifold vacuum exceeds -16.0 kPa (-120 mmHg , -4.72 inHg), portion A of the vacuum chamber is closed, and the vacuum in the chamber is kept at a constant -16.0 kPa (-120 mmHg , -4.72 inHg). As the solenoid valve is turned on or off

by the signal from the control unit, portion B or C opens or closes to allow a controlled amount of air to enter the -16.0 kPa (-120 mmHg , -4.72 inHg) vacuum passage. A properly controlled vacuum is thus sent to the E.G.R. or A.A.C. valves and controls the E.G.R. or A.A.C. valve operation.

E.G.R. CONTROL VALVE

The E.G.R. control valve controls the quantity of exhaust gas to be led to the intake manifold through vertical movement of the taper valve connected to the diaphragm, to which vacuum is applied in response to the opening of the throttle valve.

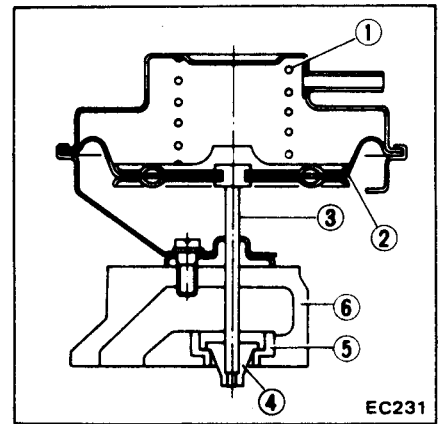
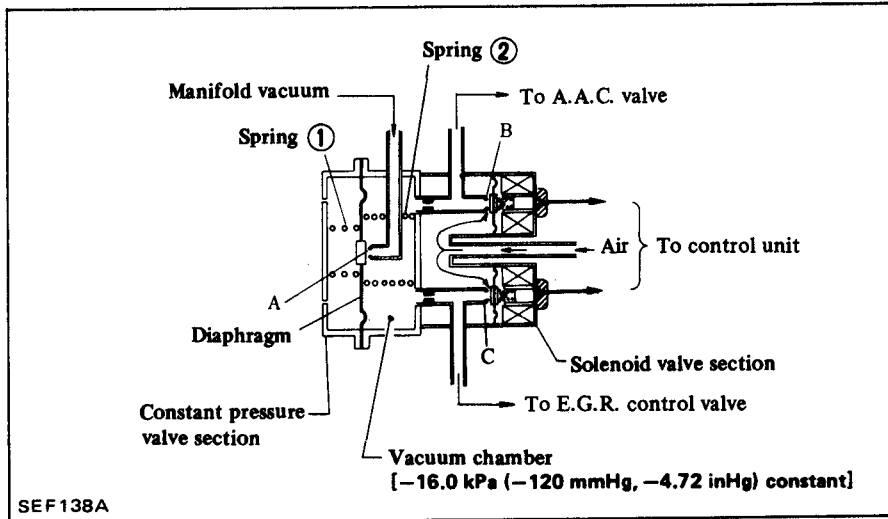

- | | |
|--------------------|-----------------|
| 1 Diaphragm spring | 4 Valve |
| 2 Diaphragm | 5 Valve seat |
| 3 Valve shaft | 6 Valve chamber |

IDLE SPEED CONTROL

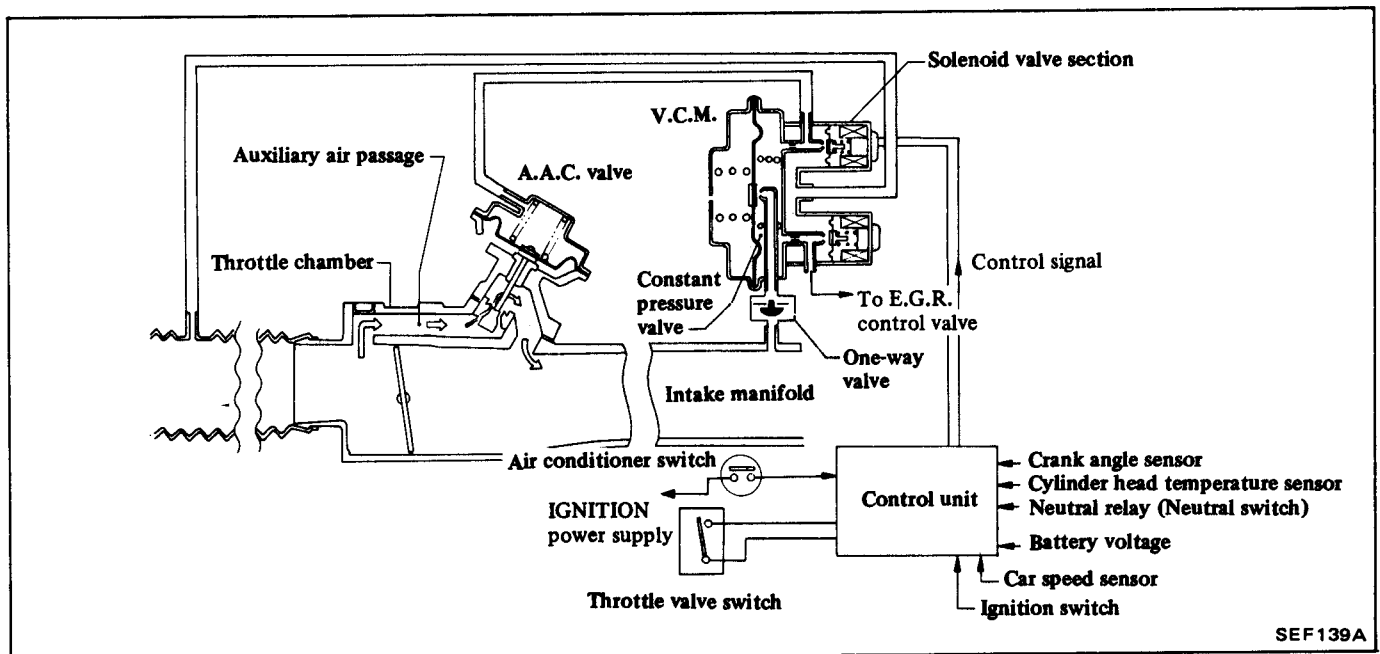

The idle speed is controlled by the central electronic control unit adjusting to the engine operating conditions.

Cylinder head temperature, engine rpm, engine load, throttle valve and gear positions are used for the determination of idle speed.

The central electronic control unit

senses the idle conditions, and determines the appropriate idle speed at each gear position and cylinder head temperature, and sends the electric signal corresponding to the difference of the best idle speed and actual idle speed to the vacuum control modulator.

The vacuum control modulator

transforms the electric signal into a vacuum signal and transmits it to the A.A.C. valve

The A.A.C. valve has a feedback control system which controls the idle speed by the vacuum signal.

It is unnecessary to adjust the idle speed because of the idle speed feedback control.

Operation

Input		V.C.M. valve open period	A.A.C. valve open angle	Idle rpm
Cylinder head temperature sensor	Hot	Decreases	Decreases	Decreases
	Cold	Increases	Increases	Increases
Air conditioner switch	ON	Increases	Increases	Increases
	OFF	Decreases	Decreases	Decreases
Crank angle sensor (Engine rpm)	High	Decreases	Decreases	Decreases
	Low	Increases	Increases	Increases
Throttle valve switch (Idle switch)	OFF → ON	Increases	Increases	Decreases gradually
Neutral relay	N → D position	Increases	Increases	Constant
	D → N position	Decreases	Decreases	Constant

A.A.C. VALVE

The A.A.C. valve is attached to the intake manifold. It controls the quantity of air that flows through the bypass port of the throttle chamber in response to the control vacuum from the V.C.M. valve.

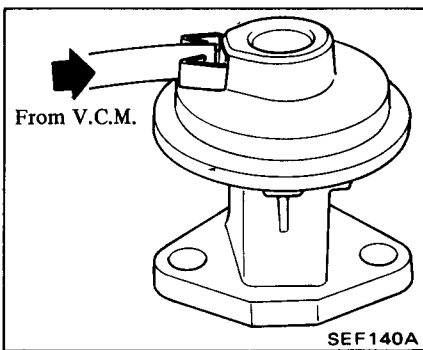

Operation

Control vacuum from V.C.M. valve kPa (mmHg, inHg)	Opening of A.A.C. valve's air passage
0 (0, 0)	Fully open
0 (0, 0) → -16.0 (-120, -4.72)	Open to close
-16.0 (-120, -4.72)	Fully closed

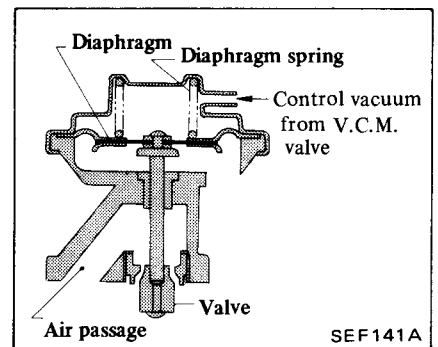

VACUUM CONTROL MODULATOR

Refer to E.G.R. CONTROL.

ONE-WAY VALVE

Refer to E.G.R. CONTROL.

AIR FLOW SYSTEM

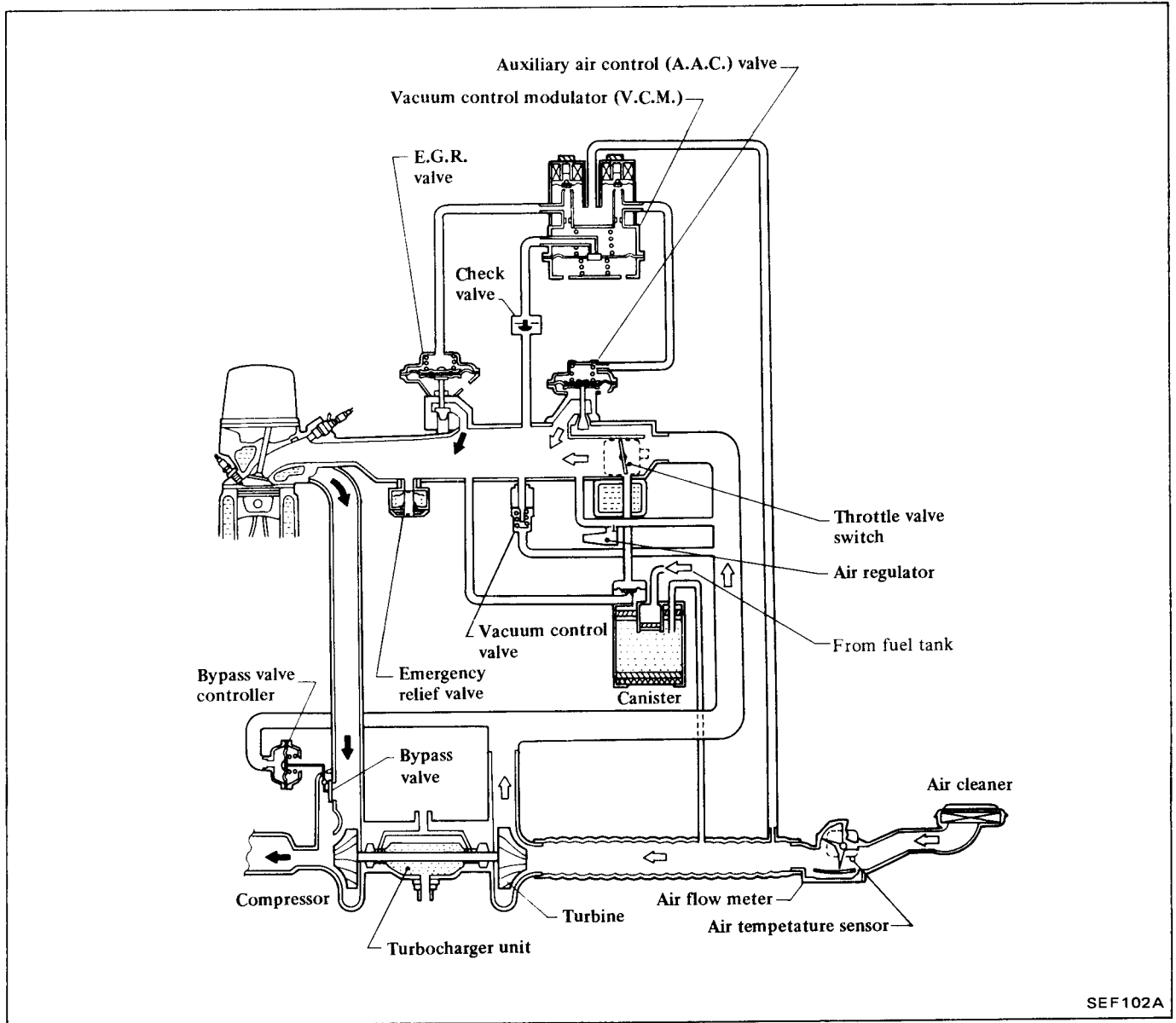

AIR CLEANER

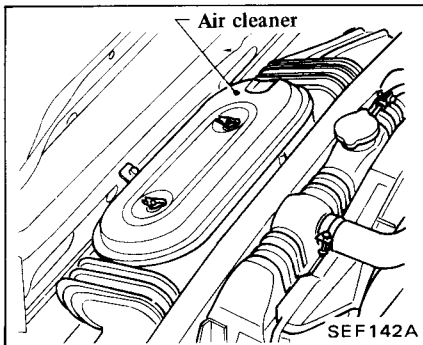

Inspection

Replace filter more frequently under dusty driving conditions.

AIR FLOW METER

Refer to FUEL INJECTION CONTROL.

TURBOCHARGER

The turbocharger is installed on the exhaust manifold. This system utilizes exhaust gas energy to rotate the turbine wheel which drives the compressor turbine installed on the other end of the turbine wheel shaft. The compressor supplies compressed air to the engine to increase the charging efficiency so as to improve engine output and torque.

To prevent an excessive rise in the supercharging pressure, a system is adopted which maintains the turbine

speed within a certain range by controlling the quantity of exhaust gas that passes through the turbine. This system consists of a by-pass valve controller which detects the supercharged pressure and activates a by-pass valve that allows a part of exhaust gas to be discharged without passing through the turbine.

To prevent an abnormal rise in supercharging pressure and possible engine damage in case of a malfunction, an emergency relief valve is provided as a safety device in the intake manifold.

As the engine speed increases and the supercharging pressure approaches the specified pressure value P_0 , it exerts a force on the diaphragm of the by-pass valve controller, thereby opening the by-pass valve.

As the valve opens, part of the exhaust gas by-passes the turbine and goes directly to the exhaust tube. As a result, the turbine speed is kept constant and the supercharging pressure maintained at the specified pressure level.

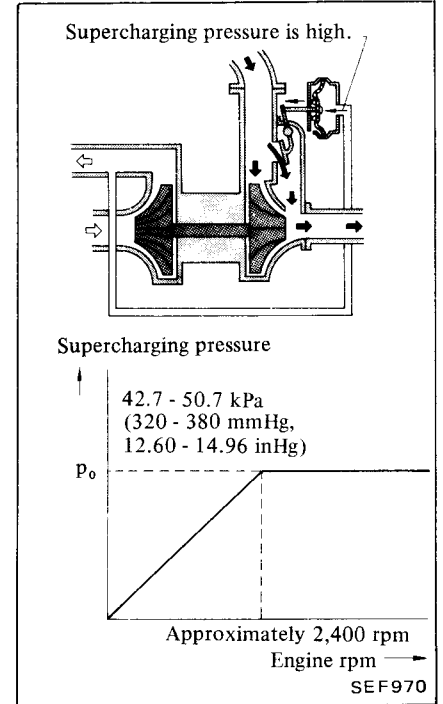
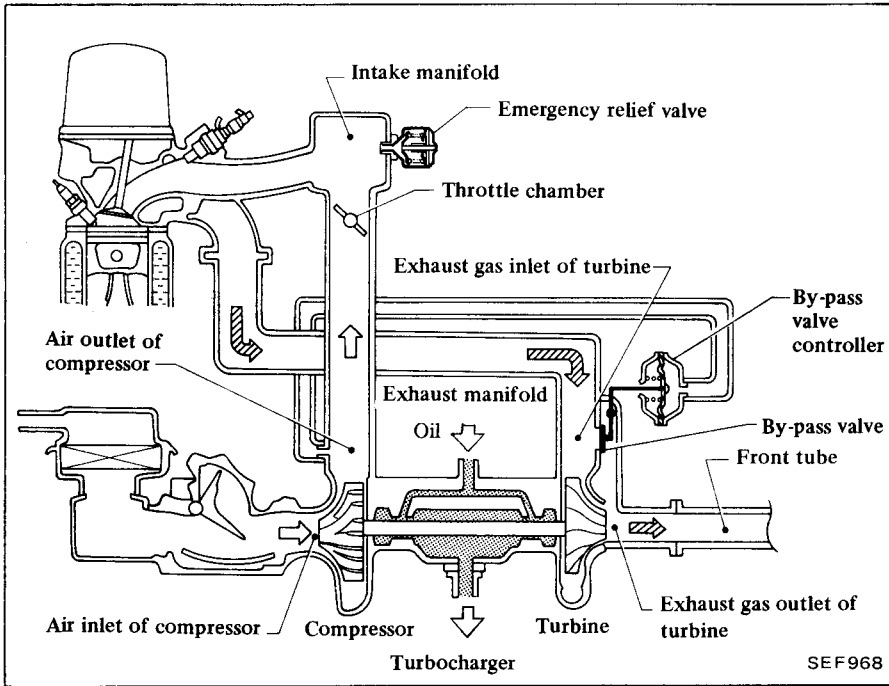

Operation

The by-pass valve controller normally detects the supercharging pressure at the outlet of the compressor housing. All exhaust gas flows through the turbine when the supercharging pressure is below the specified pressure P_0 .

Specified supercharging pressure

P_0 :
42.7 - 50.7 kPa
(320 - 380 mmHg,
12.60 - 14.96 inHg)

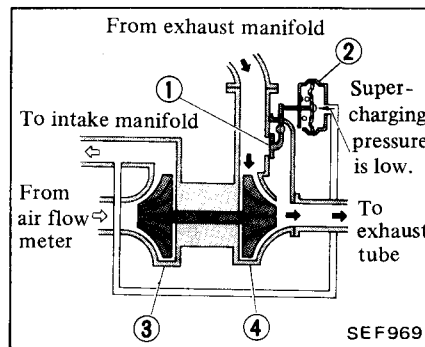

- 1 By-pass valve
- 2 By-pass valve controller
- 3 Compressor
- 4 Turbine

The emergency relief valve operates as follows:

When the pressure in the intake manifold exceeds P_{max} , it exerts a force on diaphragm. Then the upper cover, connected to the diaphragm by a shaft, is pushed open, and the excess pressure in the intake manifold is released into the atmosphere.

P_{max} :

50.7 - 53.3 kPa
(380 - 400 mmHg,
14.96 - 15.75 inHg)

When the pressure in the intake manifold is below P_{max} .

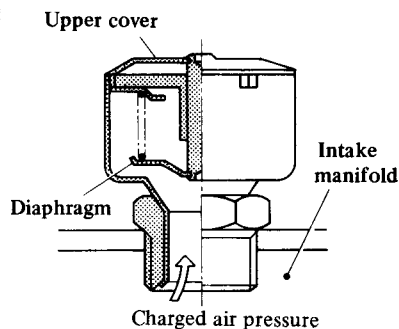

When the pressure in the intake manifold is above P_{max} .

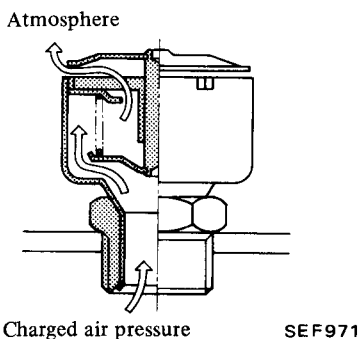

1. Remove heat insulator, inlet tube, air duct hose and suction air pipe.
2. Disconnect exhaust gas sensor harness connector, front tube, oil delivery tube and oil drain pipe.

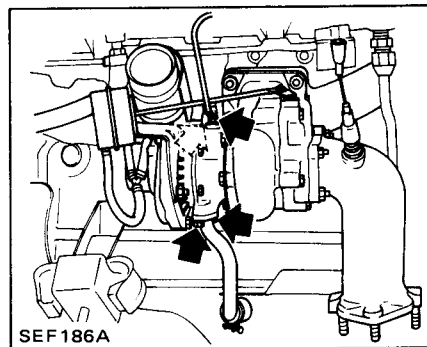

3. Loosen nuts fixing turbocharger to exhaust manifold, and then remove turbocharger.

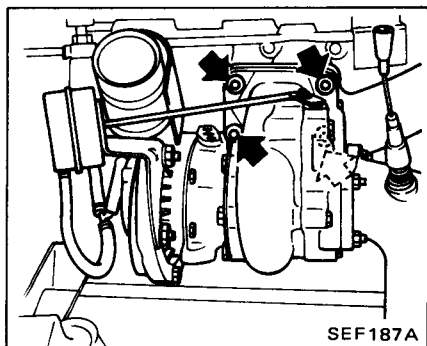

Removal and installation

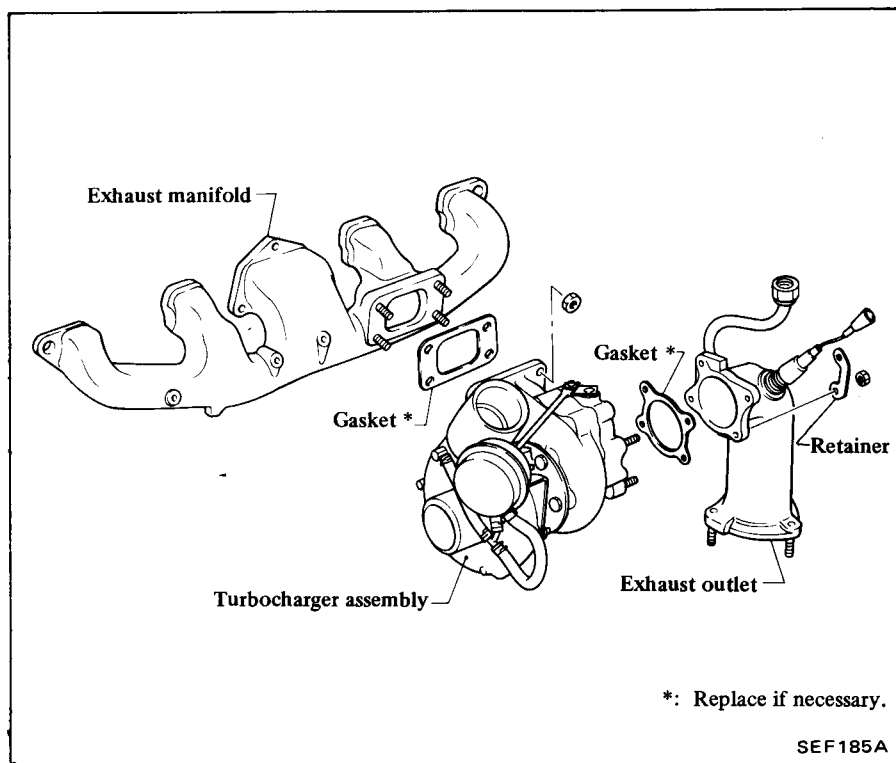

4. Install in the reverse order of removal.

Disassembly and assembly

Turbocharger should not be disassembled.

Inspection

1. Inspect turbine and compressor wheels for cracks, clogging, deformity or other damage.
2. Revolve wheels to make sure that they turn freely without any abnormal noise.
3. Measure play in axial direction.

Play (Axial direction):
0.013 - 0.091 mm
(0.0005 - 0.0036 in)

Do not allow wheels to turn when axial play is being measured.

4. Check operation of by-pass valve controller.

Do not apply more than 66.7 kPa (500 mmHg, 19.69 inHg) pressure to controller diaphragm.

By-pass valve controller stroke/pressure:

0.38 mm (0.0150 in)/
41.9 - 47.2 kPa
(314 - 354 mmHg,
12.36 - 13.94 inHg)

5. Move by-pass valve to make sure that it is not stuck or scratched.
6. Always replace turbocharger as an assembly if any of the above items shows abnormalities.

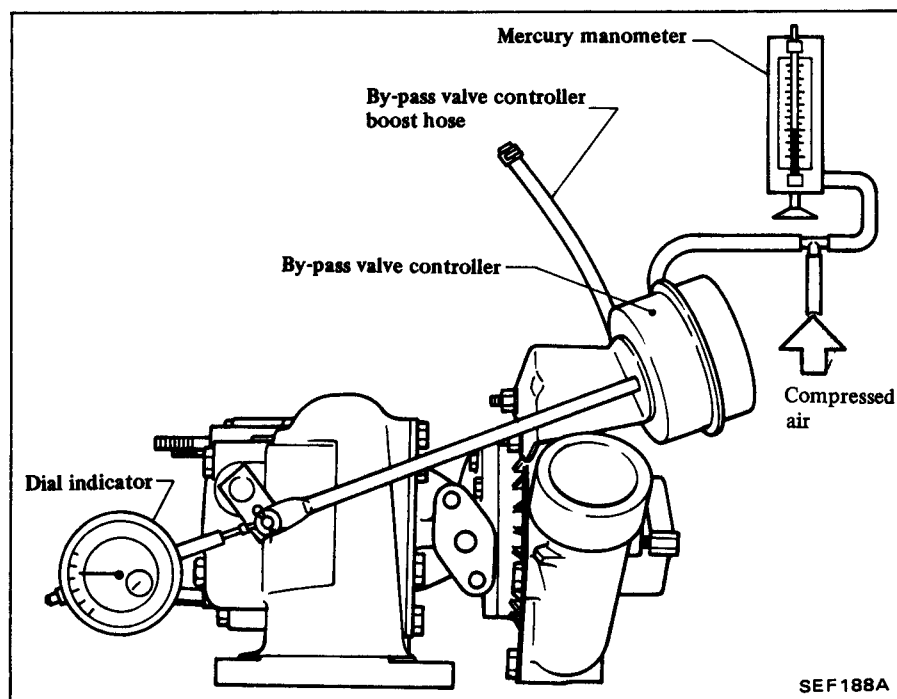
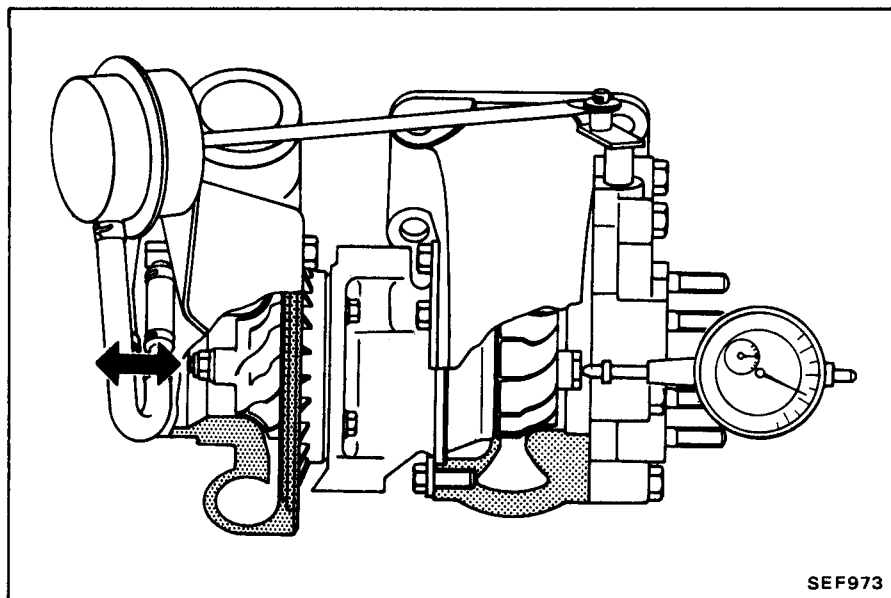

Trouble diagnoses and corrections

Before using this chart, check the following items.

- Vacuum hoses and connections
- Wires and connections
- Engine fuel system
- Emission control system

Condition 1: Low engine power

Probable cause	Corrective action
Air leak at the connection of compressor housing and suction hose/inlet tube, or inlet tube and intake manifold.	Correct the connection.
Exhaust gas leak at the connection of turbine housing and exhaust manifold, or exhaust outlet	Correct the connection or replace gasket.
By-pass valve is stuck open.	Replace turbocharger assembly.
Stuck or worn journal or bearing	
Broken shaft	
Sludge on back of turbine wheel	
Broken turbine wheel	

Condition 2: Excessively high engine power

Probable cause	Corrective action
Disconnected or cracked rubber hose	Correct or replace rubber hose.
By-pass valve is stuck closed.	Replace turbocharger assembly.
Controller diaphragm is broken.	

Condition 3: Excessively high oil consumption or exhaust shows pale blue smoke

Probable cause	Corrective action
Oil leak at the connection of lubricating oil passage	Correct the connection. Replace turbocharger assembly.
Oil leak at oil seal of turbine	
Oil leak at oil seal of compressor	
Worn journal or bearing	

AUXILIARY COOLING FAN

DESCRIPTION

The auxiliary cooling fan is located in the engine compartment. The cooling fan operates after ignition switch is turned off, and thereby cooling down the temperature of fuel inside the injector and fuel hoses in the engine compartment.

tion switch is turned off, and thereby cooling down the temperature of fuel inside the injector and fuel hoses in the engine compartment.

OPERATION

- As soon as the ignition switch is turned off at an engine coolant temperature of above about the specified value, the cooling fan operates.
 - When the ignition switch is turned off at an engine coolant temperature of below about the specified value, the cooling fan operates when the engine coolant temperature rises above about the specified value.
- a. The cooling fan operates for about 17 minutes after the ignition switch is turned off.
 - b. When the ignition switch is turned to the "ON" or "START" position, the cooling fan will stop even though it is in operation.

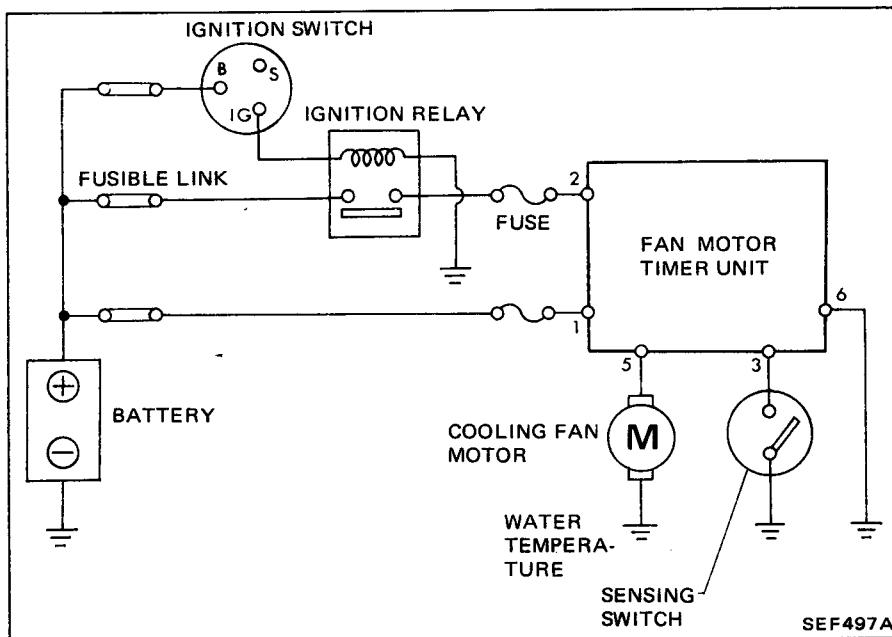

Auxiliary cooling fan operation chart

Cooling water temperature °C (°F)		Water temperature sensing switch	Ignition switch	Auxiliary cooling fan
E.F.I.	above about 102 (216)	ON	"OFF" "ACC"	Operates
E.C.C.S.	above about 100 (212)			
E.F.I.	above about 102 (216)	OFF		Does not operate
E.C.C.S.	below about 100 (212)			
—		—	"ON" "START"	

INSPECTION

ENTIRE CHECK

This check can be made at water temperatures below the specified value.

1. After turning ignition switch "ON", set it at "OFF" position and operate timer.

2. Disconnect harness connector of water temperature sensing switch and make a signal which indicates that water temperature has exceeded the specified value, by grounding connector terminal at harness side.

- Cooling fan operatesO.K.
- Cooling fan does not operate N.G.

3. If cooling fan does not operate, check fan motor timer unit and fan motor as a part.

FAN MOTOR

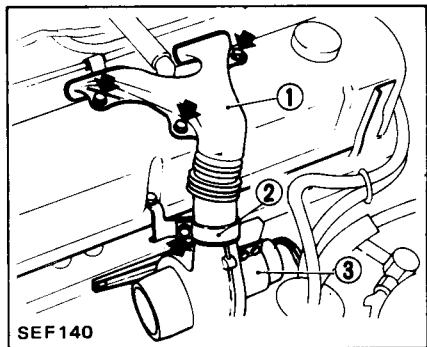

SEF140

- 1 Air duct
- 2 Clamp
- 3 Cooling fan

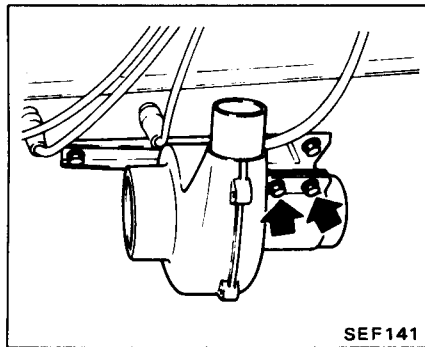

1. Make sure continuity exists between connector terminals (A) and (B).
2. Then securely connect positive terminal of a 12-volt d.c. power supply to terminal (A), and ground terminal (B).

Fan motor should run. If not running, the motor is out of order.

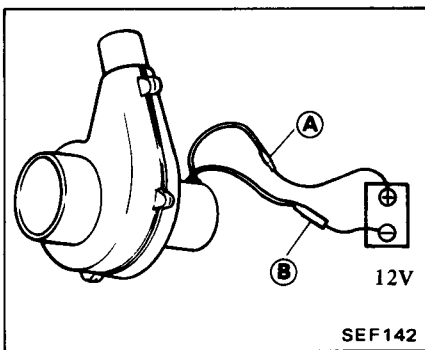

FAN MOTOR TIMER UNIT

The fan motor timer unit is located inside the R.H. dash side panel.

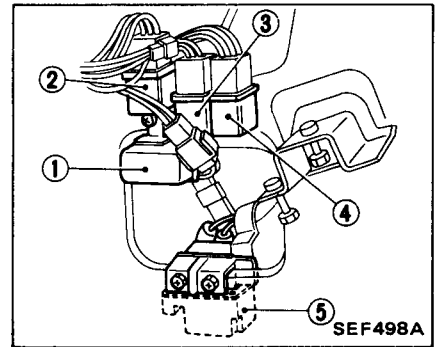

- 1 Seat belt warning timer unit
- 2 Fuel pump relay
- 3 Ignition relay
- 4 Accessory relay
- 5 Fan motor timer unit

Test timer unit with a power source of 12-volt DC and test lamp following the procedure below.

Prepare 12V-3W lamp.

1. Connect terminal (6) to negative terminal of power source, terminal (5) to test lamp terminal and the other test lamp terminal to negative terminal of the power source.
2. Connect terminal (1) to positive terminal of power source.
 - Test lamp does not glowO.K.
 - Test lamp glows N.G.
3. Connect terminal (2) to positive terminal of power source and disconnect it. (Operate timer)
4. Connect terminal (3) to negative terminal of power source.
 - Test lamp glowsO.K.
 - Test lamp does not glow N.G.

5. Make sure that test lamp should remain on for about 17 minutes after step 3 is performed, and then go out.
6. While test lamp is on, connect

terminal ② to positive terminal of power source.

- Test lamp goes out O.K.
- Test lamp does not go out N.G.

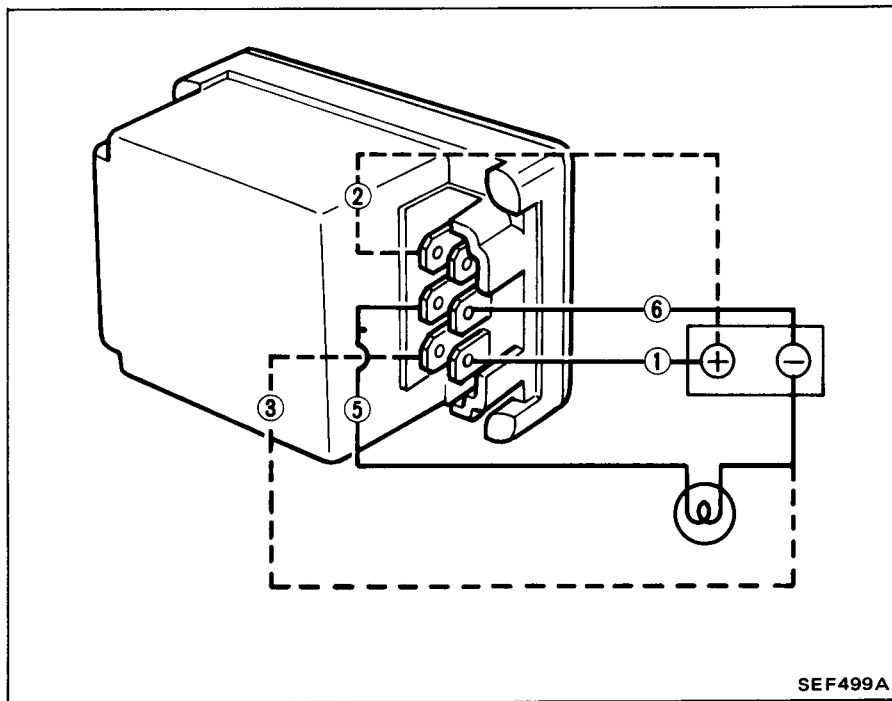

E.C.C.S. models

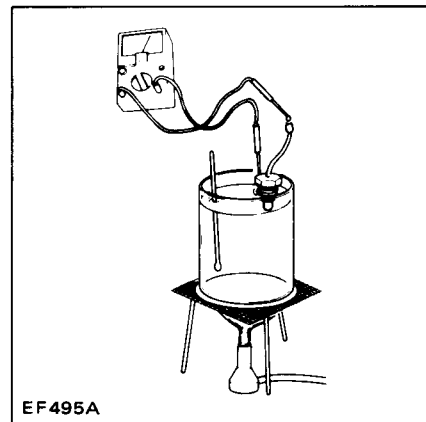
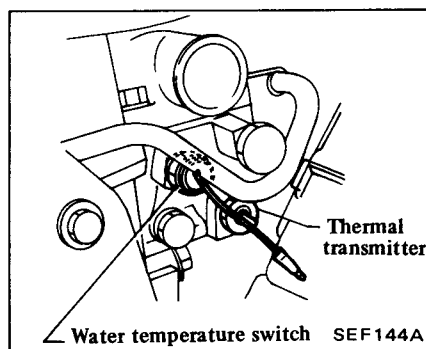

WATER TEMPERATURE SENSING SWITCH

The water temperature sensing switch is located in the thermostat housing.

E.F.I. models

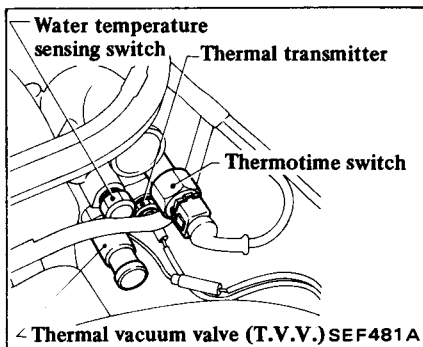

1. Dip sensing portion of water temperature sensing switch into proper solution maintained at 80°C (176°F).
2. Measure resistance between terminal of lead wire and switch body.
 - Resistance is infinite O.K.
3. Increase solution temperature, then check continuity between terminal of lead wire and switch body.
 - Resistance varies to zero at a temperature about the specified value O.K.
 If not, replace switch with a new one.

ELECTRICAL SYSTEM INSPECTION

E.F.I. CIRCUIT DIAGRAM

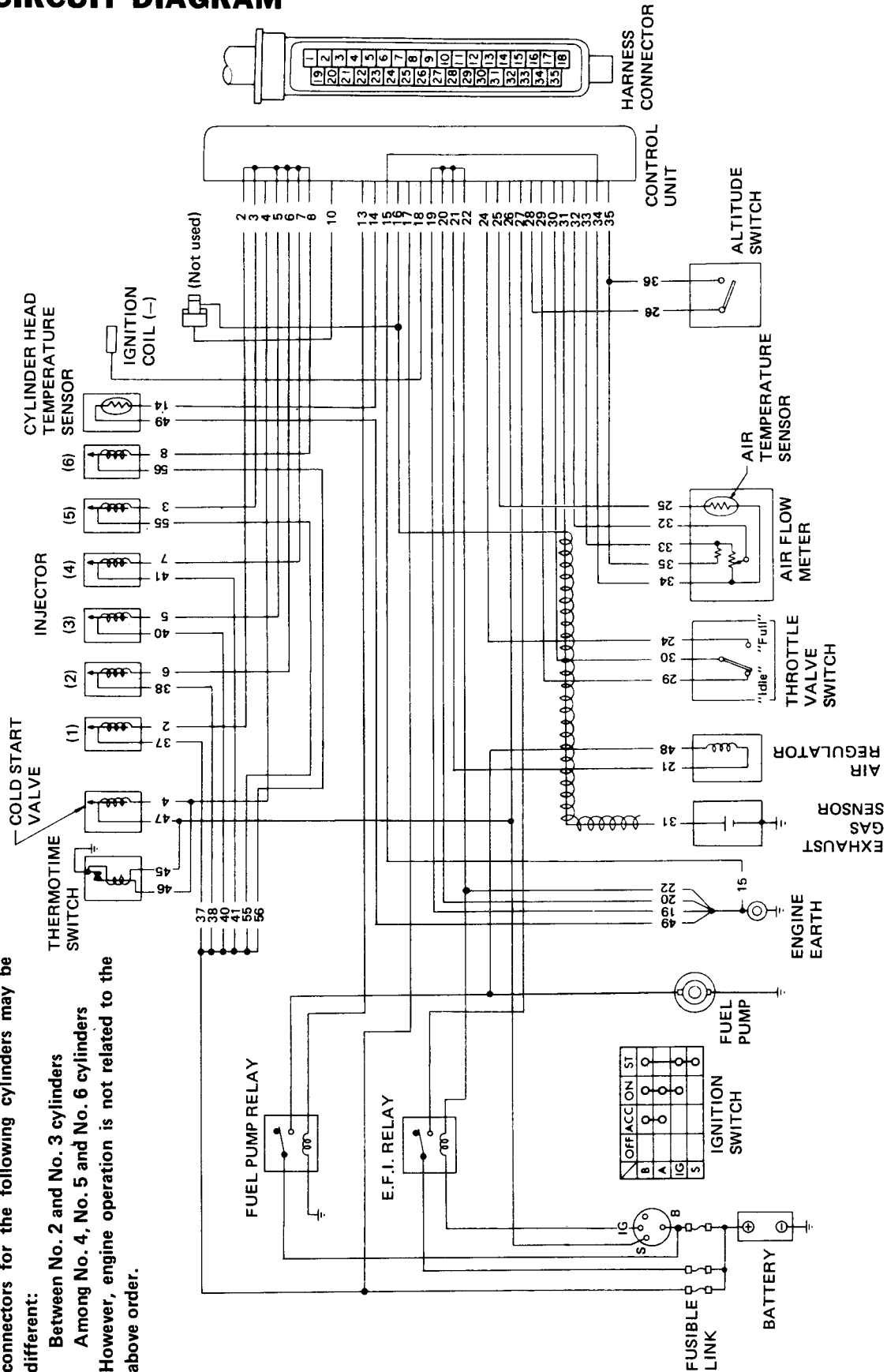

Note: When inspecting injector circuits, pay attention to the injector connectors which may not be in order; that is, it is possible that the order of the connectors for the following cylinders may be different:

Between No. 2 and No. 3 cylinders
Among No. 4, No. 5 and No. 6 cylinders
However, engine operation is not related to the above order.

DESCRIPTION

Electrical system inspection can be performed by using the E.F.I. ANALYZER (J-25400).

CAUTION:

When checking the electrical system with E.F.I. ANALYZER, be sure to use the proper adapter harness.

If the analyzer is not available, use the following procedures.

PREPARATIONS FOR INSPECTION**VEHICLE PREPARATIONS**

1. Turn ignition switch to "OFF" position.

CAUTION:

Before disconnecting and connecting electrical connectors, ensure that ignition switch is in the "OFF" position.

2. Disconnect battery ground cable.
3. Disconnect lead wire from "S" terminal of starter motor.
4. Disconnect cold start valve harness connector.
5. Arrange so that air flow meter flap can be pushed manually from air cleaner side.
6. Disconnect exhaust gas sensor harness connector.
7. Connect E.F.I. harness terminal for exhaust gas sensor to ground with a jumper wire.

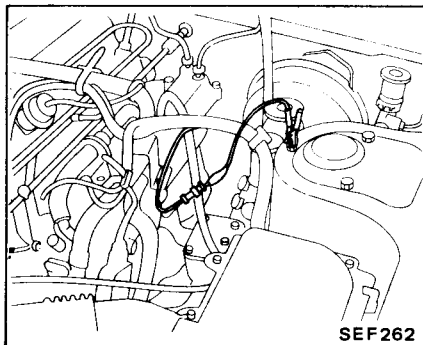

8. Disconnect 35-pin E.F.I. harness connector from control unit.

CAUTION:

- a. Before disconnecting E.F.I. harness at 35-pin connector, ensure that ignition switch is in the "OFF" position.
- b. Be extremely careful not to break or bend 35-pin when disconnecting terminal.
Do not touch the circuit tester probe to any unnecessary pin on the 35-pin connector. Doing so could cause damage to the circuit tester.
- c. After inspection or replacement, securely connect E.F.I. harness connector with control unit, and then test it to make sure.

THROTTLE VALVE SWITCH TESTS

Test No. 1 Idle contacts

Tester	Leads to Pins		Notes	Should Read
	(+)	(-)		
Ohmmeter			Throttle released	Continuity
	29	30	Throttle depressed	No continuity

SEF681

If test is O.K., go to Test No. 2.
 If test is not O.K., go to Throttle Valve Switch Adjustment.

Test No. 2 Full throttle contacts

Tester	Leads to Pins		Notes	Should Read
	(+)	(-)		
Ohmmeter			Throttle released	No continuity
	24	30	Full throttle	Continuity

SEF682

If test is O.K., go to Test No. 3.
 If test is not O.K., go to Full Throttle Contact Check.

Test No. 3 Insulation test

Tester	Leads to Pins		Notes	Should Read
	(+)	(-)		
Ohmmeter	24	Body ground		$\infty \Omega$
	29			
	30			

SEF683

Component check

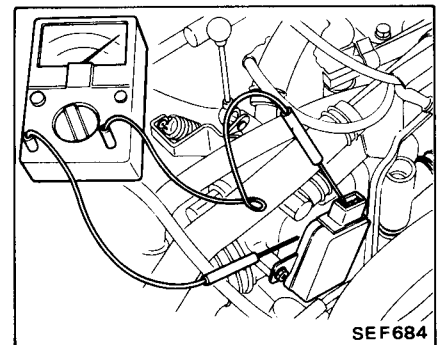

Connect ohmmeter between engine and terminals 24, 29 and 30. Ohmmeter reading should be infinite.

If test is O.K., check harness.
 If test is not O.K., replace component and retest.

If test is O.K., go to Throttle Valve Switch Adjustment.

If test is not O.K., go to Component Check.

THROTTLE VALVE SWITCH ADJUSTMENT

Ohmmeter method

1. Disconnect throttle valve switch connector.
2. Connect ohmmeter between terminals ②⑨ and ③①, and make sure continuity exists.

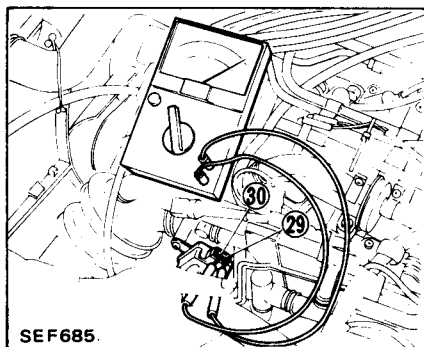

3. Adjust throttle valve switch position, with retaining screw, so that idle switch may be changed from "ON" to "OFF" when engine speed is about 900 rpm under no load.

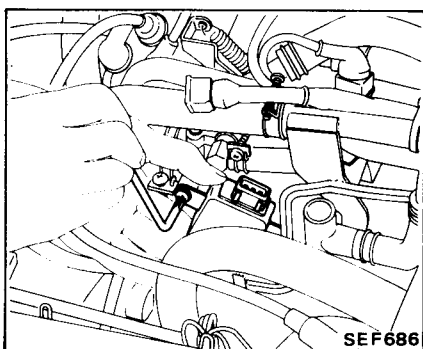

Feeler gauge method

To adjust position of throttle valve switch with engine off, proceed as follows:

When clearance "A" between throttle valve stopper screw and throttle valve shaft lever is 0.3 mm (0.012 in), adjust throttle valve switch position so that idle switch is changed from "ON" to "OFF".

If clearance between throttle valve stopper screw and throttle valve shaft lever is 0.3 mm (0.012 in), engine speed will become about 900 rpm.

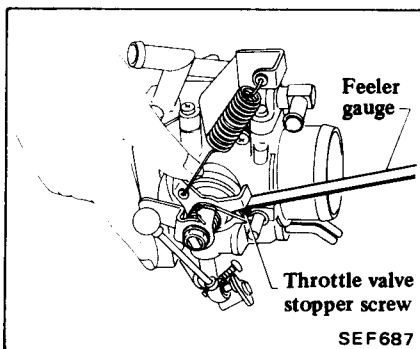

Changing idle switch from "ON" to "OFF" corresponds to change from 0 to ∞ (infinite) ohms in resistance between terminals ②⑨ and ③①.

After the adjustment is complete, proceed to Full Throttle Contact Check.

FULL THROTTLE CONTACT CHECK

1. Disconnect ground cable from battery.
2. Remove throttle valve switch connector.
3. Connect ohmmeter between terminals ②④ and ③①, and make sure continuity does not exist.

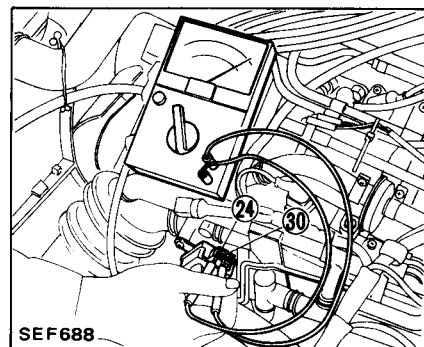

4. Depress accelerator pedal to floor. If continuity exists between terminals ②④ and ③①, full throttle contact is functioning properly.

If test is O.K., go to Insulation Test.

AIR FLOW METER TESTS

Test No. 1 Air flow meter resistance				
Tester	Leads to Pins		Notes	Should Read
	(+)	(-)		
Ohmmeter	33	34		100 to 400Ω

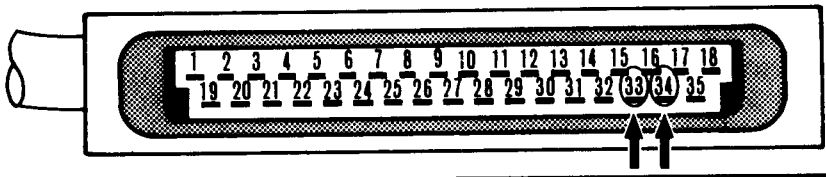

SEF689

Component check

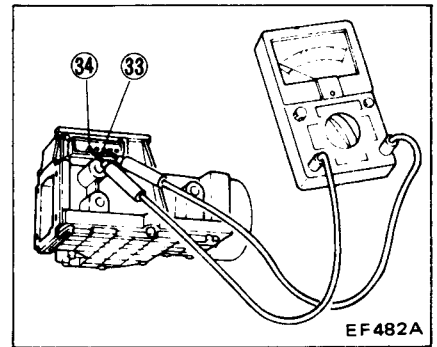

Measure the resistance between terminals 33 and 34. The standard resistance is 100 to 400 ohms.

If test is O.K., check harness.

If test is not O.K., replace component.

If test is O.K., go to Test No. 2.

If test is not O.K., perform component check.

Test No. 2 Air flow meter resistance				
Tester	Leads to Pins		Notes	Should Read
	(+)	(-)		
Ohmmeter	34	35		200 to 500Ω

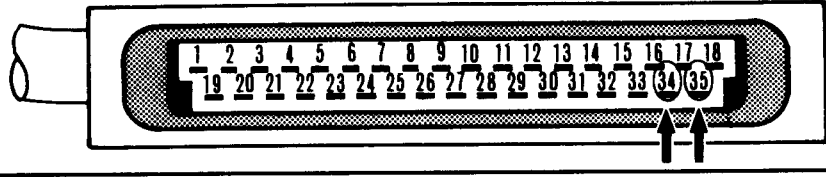

SEF690

Component check

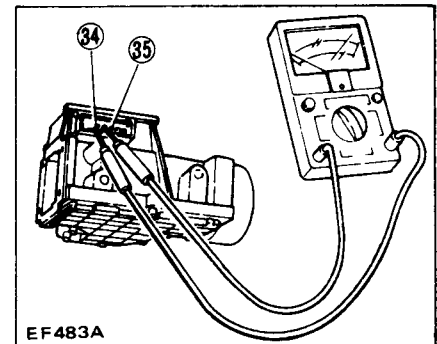

Measure the resistance between terminals 34 and 35. The standard resistance is 200 to 500 ohms.

If test is O.K., check harness.

If test is not O.K., replace component.

If test is O.K., go to Test No. 3.

If test is not O.K., perform component check.

Test No. 3 Air flow meter resistance			
Tester	Leads to Pins		Notes
	(+)	(-)	
Ohmmeter	32	34	Except 0 and $\infty\Omega$

SEF691

Component check

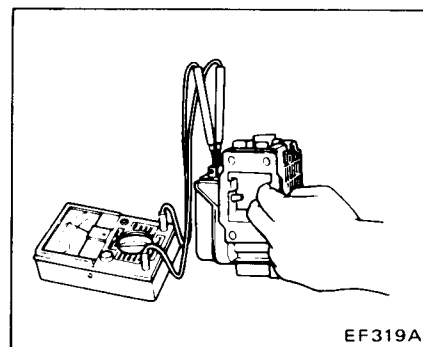

EF319A

While sliding flap, measure resistance between terminals 32 and 34. If resistance is at any value other than 0 and ∞ ohm, air flow meter is normal.

If test is O.K., check harness.

If test is not O.K., replace component.

If test is O.K., go to Test No. 4.

If test is not O.K., perform component check.

Test No. 4 Insulation resistance			
Tester	Leads to Pins		Notes
	(+)	(-)	
Ohmmeter	32 33 34 35	Body ground	$\infty\Omega$

SEF692

Component check

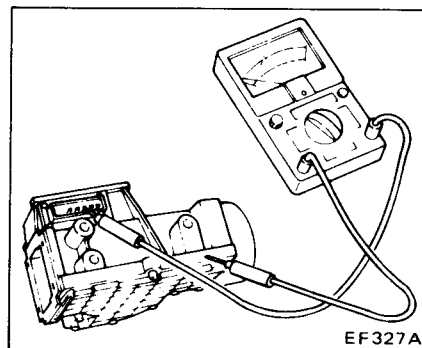

EF327A

Check insulation resistance between the air flow meter body and any one of the terminals 32, 33, 34 and 35. If continuity exists, the air flow meter is out of order.

If test is O.K., check harness.

If test is not O.K., replace component.

If test is O.K., go to Test No. 5.

If test is not O.K., perform component check.

Test No. 5 air flow meter flap.

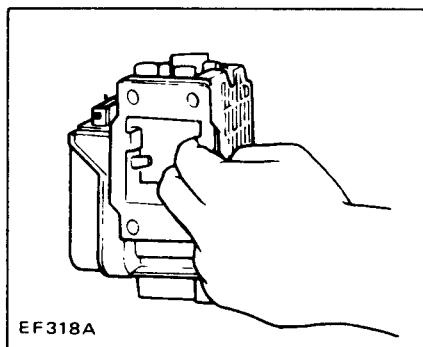

EF318A

Fully open the flap by hand to check that it opens smoothly without binding. If it doesn't, it is out of order.

If test is O.K., air flow meter is O.K.

If test is not O.K., replace air flow meter.

AIR TEMPERATURE SENSOR TESTS

Test No. 1 Air Temperature Sensor				
Tester	Leads to Pins		Notes	Should Read
	(+)	(-)		
Ohmmeter	25	34	Intake air temperature 20°C (68°F) or above	Below 2.9 kΩ
			Below 20°C (68°F)	2.1 kΩ or above

SEF772

If test is O.K., go to Test No. 2.

If test is not O.K., perform component check.

Component check

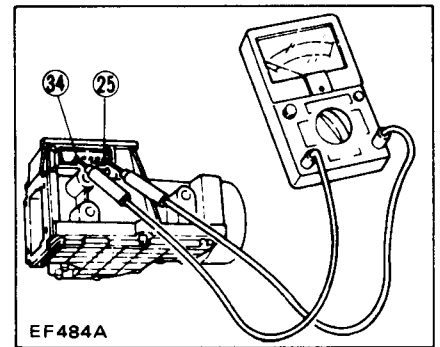

1. Measure the outside air temperature.
2. Measure resistance between terminals 25 and 34 of the air flow meter connector.

If test is O.K., check harness.

If test is not O.K., replace component.

Test No. 2 Insulation Resistance				
Tester	Leads to Pins		Notes	Should Read
	(+)	(-)		
Ohmmeter	25	Body ground		$\infty \Omega$

SEF773

If test is O.K., air temperature sensor is O.K.

If test is not O.K., perform component check.

Component check

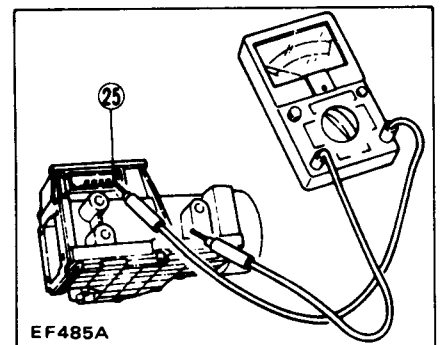

Check insulation resistance between terminal 25 and air flow meter body.

If test is O.K., check harness.

If test is not O.K., replace component.

CYLINDER HEAD TEMPERATURE SENSOR TEST

Cylinder head temperature sensor test				
Tester	Leads to Pins		Notes	Should Read
Ohmmeter	(+)	(-)	20°C (68°F) or above	Below 2.9 kΩ
	14	Body ground	Below 20°C (68°F)	2.1 kΩ or above

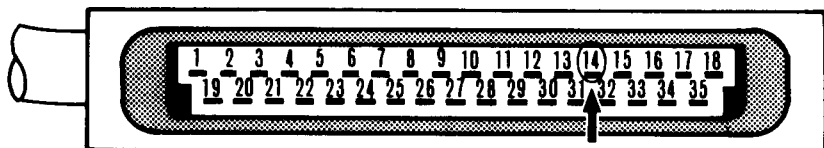

SEF693

If test is O.K., test is complete.
If test is not O.K., perform component check.

Component check

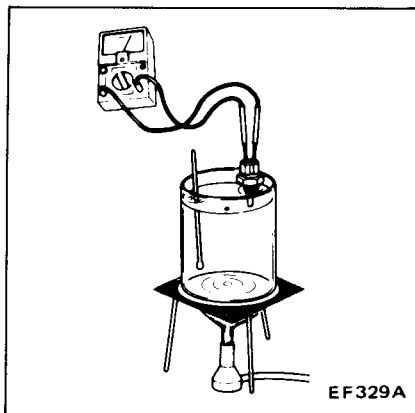

EF329A

Dip the sensor into water maintained at a temperature of 20°C (68°F), 80°C (176°F), etc., and read its resistance.

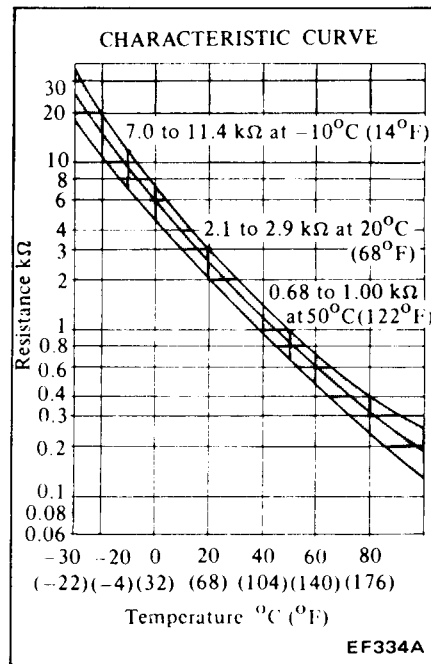

EF334A

If test matches curve, sensor is O.K. Check harness.

If test does not match curve, replace sensor.

EXHAUST GAS SENSOR CIRCUIT TEST

Exhaust gas sensor circuit test				
Tester	Leads to Pins		Notes	Should Read
Ohmmeter	(+)	(-)	Disconnect exhaust gas sensor harness connector, and connect E.F.I. harness terminal for exhaust gas sensor to ground with a jumper wire.	0Ω
	31	Body ground		

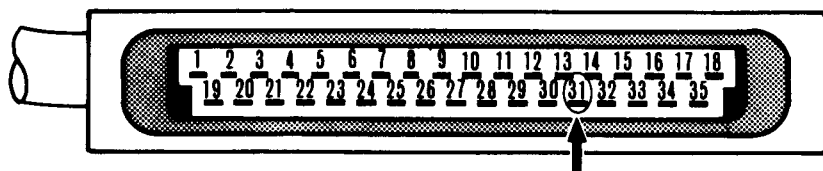

SEF694

If test is O.K., exhaust gas sensor circuit is O.K. For performing component check, refer to Section EC.

THERMOTIME SWITCH TESTS

Disconnect cold start valve harness connector.

Component check

Test No. 1 Thermotime switch contact point				
Tester	Leads to Pins		Notes	Should Read
	(+)	(-)		
Ohmmeter	4	Body ground	Water temperature 25°C (77°F) or above	$\infty\Omega$
			14 to 25°C (57 to 77°F)	0 or $\infty\Omega$
			Below 14°C (57°F)	0 Ω

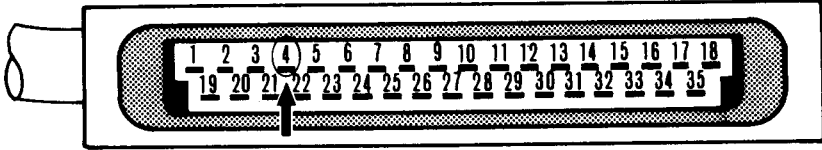

SEF695

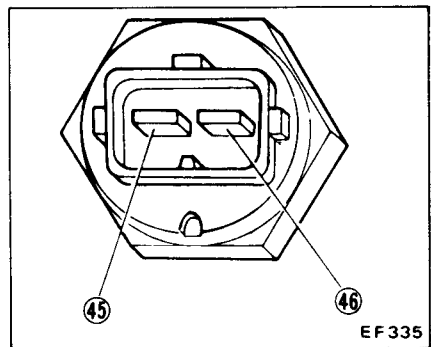

If test is O.K., go to Test No. 2.
If test is not O.K., perform component check.

Measure the resistance between terminal ④ and switch body.

- The resistance is zero when the cooling water temperature is less than 14°C (57°F). O.K.
- The resistance is infinite when the cooling water temperature is more than 25°C (77°F). O.K.

The resistance is zero or infinite when the cooling water temperature is between 14 to 25°C (57 to 77°F).

Measure the resistance between terminal ⑤ and switch body.

The ohmmeter reading is 40 to 70 ohms O.K.

If test is O.K., check harness.

If test is not O.K., replace component.

Test No. 2 Heater coil of thermotime switch bimetal				
Tester	Leads to Pins		Notes	Should Read
	(+)	(-)		
Ohmmeter	26	Body ground		40 to 70 Ω

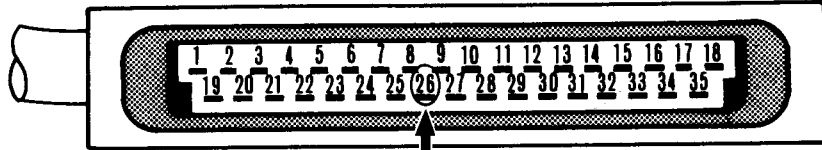

SEF696

If test is O.K., thermotime switch is O.K.

If test is not O.K., perform component check.

CONTROL UNIT GROUND CIRCUIT TESTS

Control unit ground circuit tests			
Tester	Leads to Pins		Notes
	(+)	(-)	
Ohmmeter	15	Body ground	Continuity
	19		
	20		
	22		

If tests are O.K., ground circuits are O.K.

If tests are not O.K., check wiring diagram and harness.

SEF697

AIR REGULATOR CIRCUIT TESTS

Test No. 1 Air regulator resistance			
Tester	Leads to Pins		Notes
Ohmmeter	(+)	(-)	
	21	Body ground	

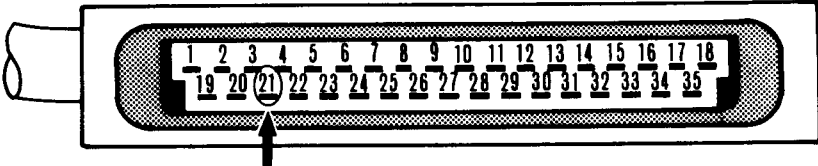

SEF698

If test is O.K., go to Test No. 2.

If test is not O.K., check air regulator.

Test No. 2 Air regulator power circuit			
Tester	Leads to Pins		Notes
Voltmeter	(+)	(-)	1. Disconnect starter motor "S" terminal. 2. Connect battery ground cable. 3. Ignition "START"
	21	Body ground	

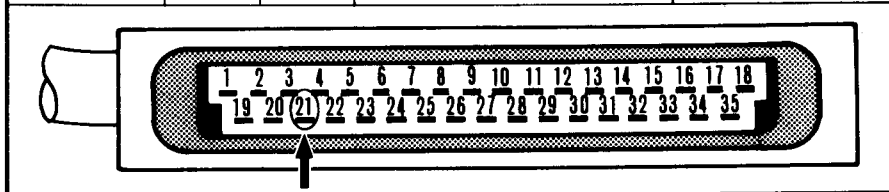

SEF699

If test is O.K., air regulator power circuit is O.K.

If test is not O.K., check fuel pump relay.

CHECKING AIR REGULATOR

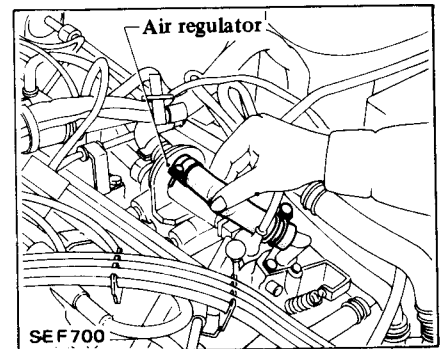

SEF700

1. Starting engine, and pinch rubber hose between throttle chamber and air regulator.

- Engine speed decreases during warm-up. O.K.
- Engine speed remains unchanged after warm-up. O.K.

2. Disconnect hoses from both ends of air regulator, and visually check to see if air regulator shutter opens.

3. Disconnect electric connector of air regulator, and check continuity. Continuity should exist. If not, air regulator is faulty.

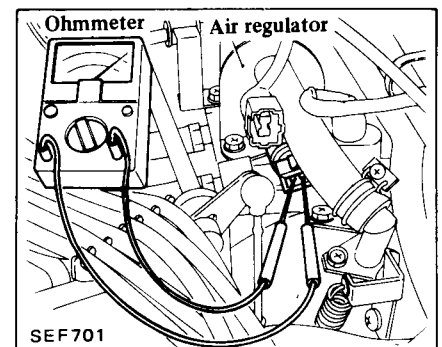

SEF701

4. Pry air regulator shutter to open with a flat-blade screwdriver, then close. If shutter opens and closes smoothly, it is operating properly.

If test is O.K., check harness.

If test is not O.K., replace component and retest.

COLD START VALVE TEST

Cold start valve circuit test				
Tester	Leads to Pins		Notes	Should Read
Voltmeter	(+)	(-)	1. Disconnect starter motor "S" terminal and thermotime switch harness connector. 2. Connect cold start valve harness connector and battery ground cable. 3. Ignition "START".	Battery voltage
	4	Body ground		

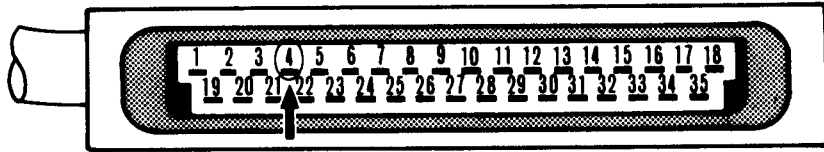

SEF704

If test is O.K., cold start valve is O.K.

If test is not O.K., perform component check.

Component check

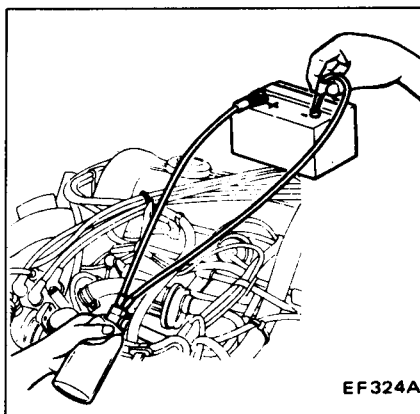

EF324A

1. Disconnect ground cable from battery.
2. Remove two screws securing cold start valve to intake manifold, and extract cold start valve.
3. Put cold start valve into a transparent glass container, plug the transparent glass container opening with a clean rag.
4. Using two jumper wires, connect each terminal to cold start valve connector.
5. Connect other terminals of jumper wire to battery positive and negative terminals.

- Fuel is injected. O.K.
- Fuel is not injected. N.G.

CAUTION:

Be careful to keep both terminals separate in order to avoid short circuit.

- If test is O.K., check harness.
- If test is not O.K., replace component and retest.

IGNITION COIL TRIGGER INPUT TEST

Ignition coil trigger input test				
Tester	Leads to Pins		Notes	Should Read
Voltmeter	(+)	(-)	1. Connect starter motor "S" terminal and battery ground cable. 2. Ignition "START".	Pointer deflects.
	18	Body ground		

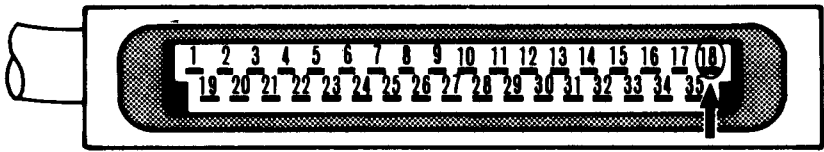

SEF705

If test is O.K., trigger input to control unit is O.K.

If test is not O.K., check ignition coil and wire harness.

INJECTOR CIRCUIT TESTS

Test No. 1 Cylinder No. 1			
Tester	Leads to Pins		Notes
Voltmeter	(+)	(-)	1. Connect battery ground cable. 2. Ignition "ON".
	2	Body ground	

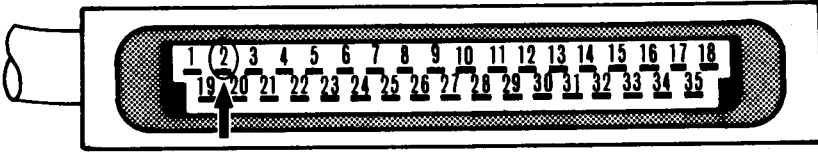

SEF706

If test is O.K., go to Test No. 2.

If test is not O.K., go to Component Check.

Test No. 2 Cylinder No. 2 or No. 3			
Tester	Leads to Pins		Notes
Voltmeter	(+)	(-)	Ignition "ON".
	6	Body ground	

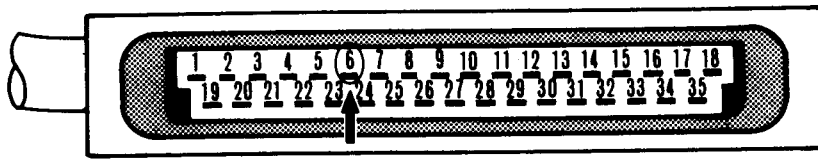

SEF707

If test is O.K., go to Test No. 3.

If test is not O.K., perform component check.

Test No. 3 Cylinder No. 3 or No. 2			
Tester	Leads to Pins		Notes
Voltmeter	(+)	(-)	Ignition "ON"
	5	Body ground	

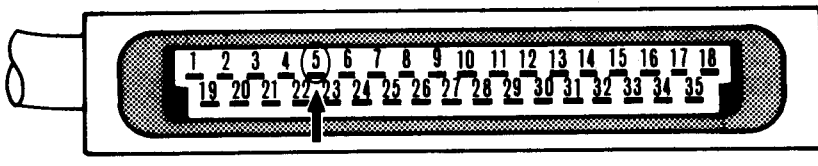

SEF708

If test is O.K., go to Test No. 4.

If test is not O.K., go to Component Check.

Component check

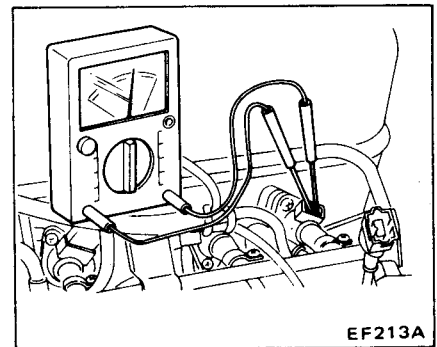

1. Disconnect ground cable from battery.
2. Disconnect electric connectors from injectors.
3. Check continuity between the two terminals. Continuity should exist. If not, injector(s) are faulty.

Test No. 4 Cylinder No. 4, No. 5 or No. 6				
Tester	Leads to Pins		Notes	Should Read
Voltmeter	(+)	(-)	Ignition "ON".	Battery voltage
	7	Body ground		

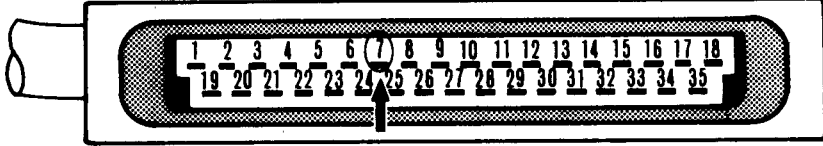

SEF709

If test is O.K., go to Test No. 5.

If test is not O.K., go to Component Check.

Test No. 5 Cylinder No. 5, No. 4 or No. 6				
Tester	Leads to Pins		Notes	Should Read
Voltmeter	(+)	(-)	Ignition "ON".	Battery voltage
	3	Body ground		

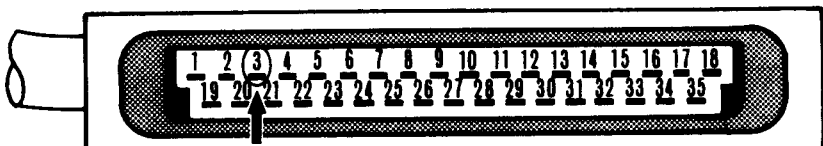

SEF710

If test is O.K., go to Test No. 6.

If test is not O.K., go to Component Check.

Test No. 6 Cylinder No. 6, No. 4 or No. 5				
Tester	Leads to Pins		Notes	Should Read
Voltmeter	(+)	(-)	Ignition "ON".	Battery voltage
	8	Body ground		

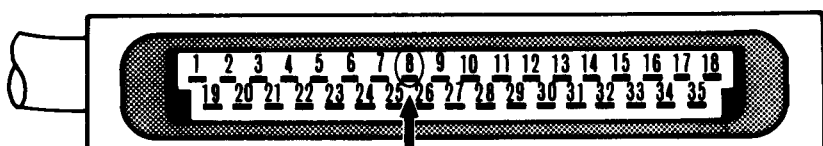

SEF712

If test is O.K., all injectors are O.K.

If test is not O.K., perform Component Check.

CHECKING E.F.I. RELAY AND FUEL PUMP RELAY

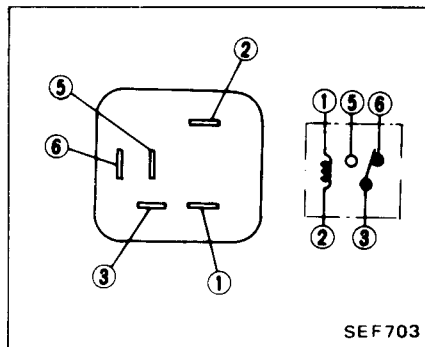

Check terminals	Normal condition	12V direct current is applied between terminals ① and ②
① - ②	Continuity	—
③ - ⑤	No continuity	Continuity
③ - ⑥	Continuity	No continuity

If E.F.I. relay and fuel pump relay are O.K., check harness.
 If fuel pump and harness are O.K., replace control unit.

IGNITION START SIGNAL TEST

Ignition start signal test				
Tester	Leads to Pins		Notes	Should Read
Voltmeter	(+)	(-)	1. Disconnect starter motor "S" terminal. 2. Connect battery ground cable. 3. Ignition "START".	Battery voltage
	26	Body ground		

SEF715

If test is O.K., ignition start signal is O.K.

If test is not O.K., inspect ignition coil and harness.

E.C.C.S. CIRCUIT DIAGRAM

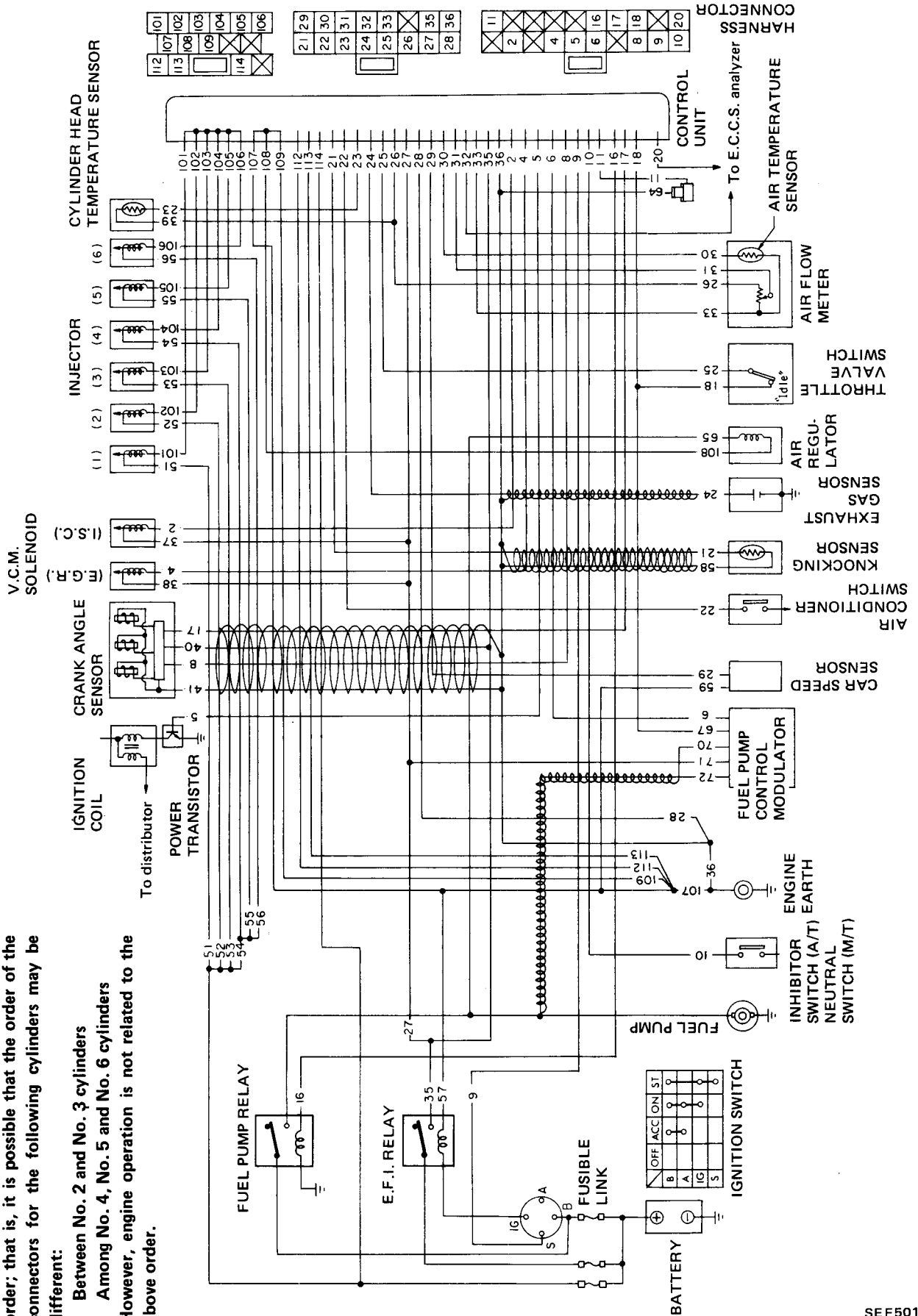

Note:
 When inspecting injector circuits, pay attention to the injector connectors which may not be in order; that is, it is possible that the order of the connectors for the following cylinders may be different:
 Between No. 2 and No. 3 cylinders
 Among No. 4, No. 5 and No. 6 cylinders
 However, engine operation is not related to the above order.

DESCRIPTION

Electrical system inspection should be performed by using the E.C.C.S. ANALYZER (J28835).

If the analyzer is not available, some components can be inspected by using the following procedures.

PREPARATIONS FOR INSPECTION

VEHICLE PREPARATIONS

1. Turn ignition switch to "OFF" position.

CAUTION:

Before disconnecting and connecting electrical connectors, ensure that ignition switch is in the "OFF" position.

2. Disconnect battery ground cable.
3. Disconnect lead wire from "S" terminal of starter motor.
4. Arrange so that air flow meter flap can be pushed manually from air cleaner side.
5. Disconnect 15-pin, 20-pin and 16-pin E.C.C.S. harness connectors from control unit.

CAUTION:

- a. Before disconnecting ECCS harness at 15-pin, 20-pin and 16-pin connectors, ensure that ignition switch is in the "OFF" position.
- b. Be extremely careful not to break or bend 15-pin, 20-pin and 16-pin when disconnecting terminal. Do not touch the circuit tester probe to any unnecessary pin on the 15-pin, 20-pin and 16-pin connectors. Doing so could cause damage to the circuit tester.
- c. After inspection or replacement, connect E.C.C.S. harness connectors with control unit securely and make sure that connectors are secured properly. (At this time, a click may be heard.)

THROTTLE VALVE SWITCH TESTS

Test No. 1 Idle contacts				
Tester	Leads to Pins		Notes	Should Read
	(+)	(-)		
Ohmmeter	18	25	Throttle depressed	No continuity
			Throttle released	Continuity

SEF502A

If test is O.K., go to Test No. 2.
If test is not O.K., go to Throttle Valve Switch Adjustment.

Test No. 2 Insulation test				
Tester	Leads to Pins		Notes	Should Read
	(+)	(-)		
Ohmmeter	18	Body ground		$\infty \Omega$
	25			

SEF502A

If test is O.K., go to Throttle Valve Switch Adjustment.

If test is not O.K., go to Component Check.

Component check

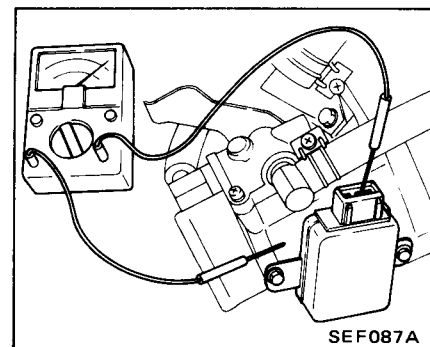

SEF087A

Connect ohmmeter between engine and terminals ⑱ and ㉕. Ohmmeter reading should be infinite.

If test is O.K., check harness.

If test is not O.K., replace component and retest.

ADJUSTMENT

Refer to THROTTLE VALVE SWITCH.

AIR FLOW METER TESTS

Test No. 1 Air flow meter resistance			
Tester	Leads to Pins		Notes
	(+)	(-)	
Ohmmeter	33	26	Approx. 280 to 400Ω

SEF504A

If test is O.K., go to Test No. 2.

If test is not O.K., perform component check.

Component check

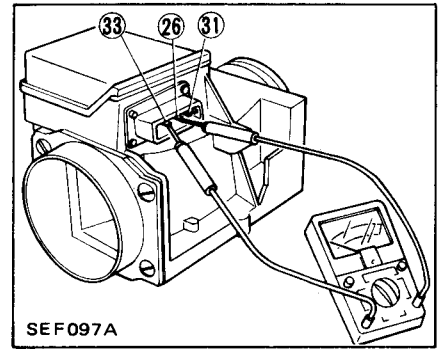

Measure the resistance between terminals 26 and 33. The standard resistance is approximately 280 to 400 ohm.

If test is O.K., check harness.

If test is not O.K., replace component.

Test No. 2 Air flow meter resistance			
Tester	Leads to Pins		Notes
	(+)	(-)	
Ohmmeter	33	31	Except 0 and ∞Ω

SEF505A

If test is O.K., go to Test No. 3.

If test is not O.K., perform component check.

Component check

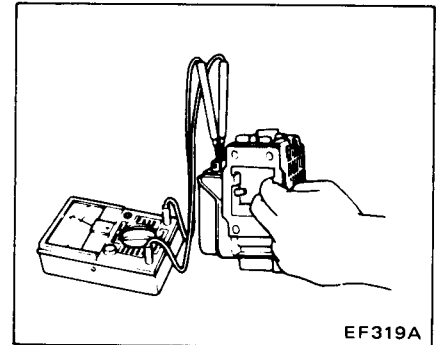

While sliding flap, measure resistance between terminals 33 and 31. If resistance is at any value other than 0 and ∞ ohm, air flow meter is normal.

If test is O.K., check harness.

If test is not O.K., replace component.

Test No. 3 Insulation resistance

Tester	Leads to Pins		Notes	Should Read
Ohmmeter	(+)	(-)		$\infty \Omega$
	26	Body ground		
	31			
33				

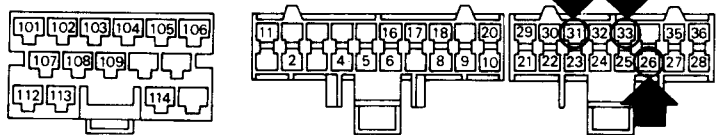

SEF506A

Component check

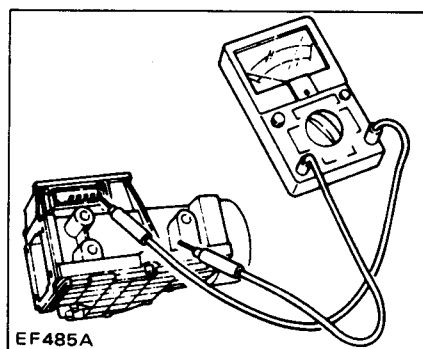

EF485A

Check insulation resistance between the air flow meter body and any one of the terminals 26, 31 and 33. If continuity exists, the air flow meter is out of order.

If test is O.K., check harness.

If test is not O.K., replace component.

If test is O.K., go to Test No. 4.

If test is not O.K., perform component check.

Test No. 4 air flow meter flap

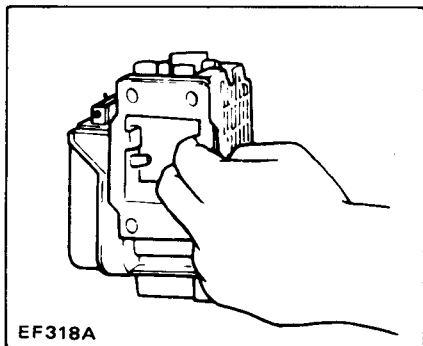

EF318A

Fully open the flap by hand to check that it opens smoothly without binding. If it doesn't, it is out of order.

If test is O.K., air flow meter is O.K.

If test is not O.K., replace air flow meter.

AIR TEMPERATURE SENSOR TESTS

Test No. 1 Air Temperature Sensor				
Tester	Leads to Pins		Notes	Should Read
	(+)	(-)		
Ohmmeter	33	30	Intake air temperature 20°C (68°F) or above	Below 2.9 kΩ
			Below 20°C (68°F)	2.1 kΩ or above

SEF507A

Component check

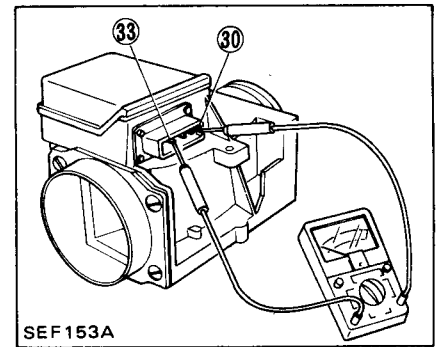

1. Measure the outside air temperature.
2. Measure resistance between terminals 33 and 30 of the air flow meter connector.

If test is O.K., check harness.

If test is not O.K., replace component.

If test is O.K., go to Test No. 2.

If test is not O.K., perform component check.

Test No. 2 Insulation Resistance				
Tester	Leads to Pins		Notes	Should Read
	(+)	(-)		
Ohmmeter	30	Body ground		$\infty \Omega$

SEF508A

Component check

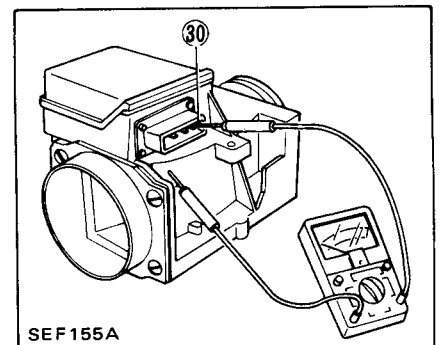

Check insulation resistance between terminal 30 and air flow meter body.

If test is O.K., check harness.

If test is not O.K., replace component.

If test is O.K., air temperature sensor is O.K.

If test is not O.K., perform component check.

CYLINDER HEAD TEMPERATURE SENSOR TEST

Cylinder head temperature sensor test				
Tester	Leads to Pins		Notes	Should Read
Ohmmeter	(+)	(-)	20°C (68°F) or above	Below 2.9 kΩ
	23	Body ground	Below 20°C (68°F)	2.1 kΩ or above

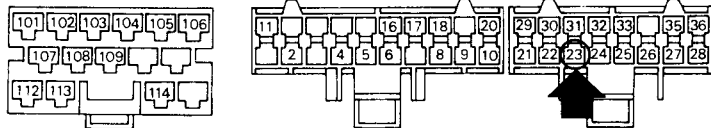

SEF509A

If test is O.K., test is complete.
If test is not O.K., perform component check.

Component check

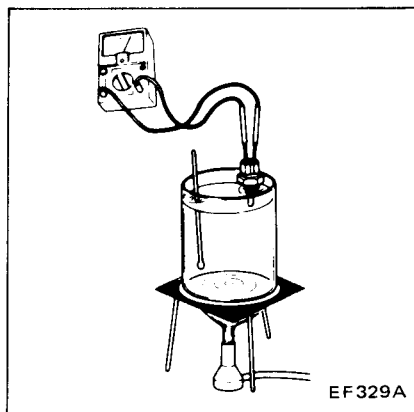

EF329A

Dip the sensor into water maintained at a temperature of 20°C (68°F), 80°C (176°F), etc., and read its resistance.

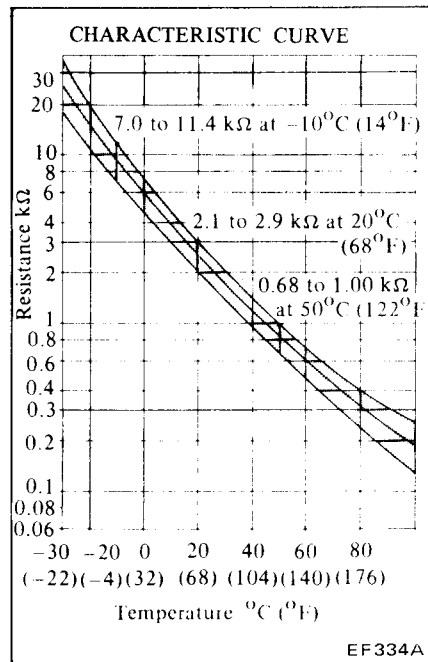

EF334A

If test matches curve, sensor is O.K.
Check harness.

If test does not match curve, replace sensor.

EXHAUST GAS SENSOR CIRCUIT TEST

Exhaust gas sensor circuit test				
Tester	Leads to Pins		Notes	Should Read
Ohmmeter	(+)	(-)	Disconnect exhaust gas sensor harness connector, and connect E.F.I. harness terminal for exhaust gas sensor to ground with a jumper wire.	0Ω
	24	Body ground		

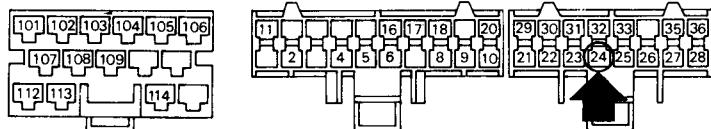

SEF510A

If test is O.K., exhaust gas sensor circuit is O.K.

CONTROL UNIT GROUND CIRCUIT TESTS

Control unit ground circuit tests				
Tester	Leads to Pins		Notes	Should Read
Ohmmeter	(+)	(-)		Continuity
	28	109		
	36	112		
	107	113		
	108	Body ground		

SEF511A

If tests are O.K., ground circuits are O.K.

If tests are not O.K., check wiring diagram and harness.

AIR REGULATOR AND FUEL PUMP RELAY TESTS

Test No. 1 Air regulator resistance				
Tester	Leads to Pins		Notes	Should Read
Ohmmeter	(+)	(-)		25 to 90Ω
	108	Body ground		

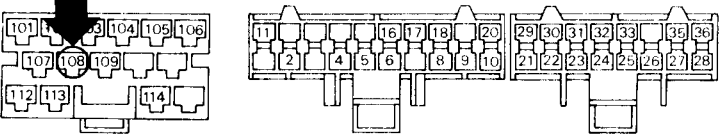

SEF512A

CHECKING AIR REGULATOR

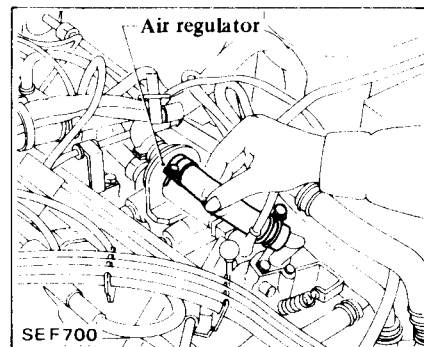

If test is O.K., go to Test No. 2.

If test is not O.K., check air regulator.

1. Starting engine, and pinch rubber hose between throttle chamber and air regulator.

- Engine speed decreases during warm-up. O.K.
- Engine speed remains unchanged after warm-up. O.K.

2. Disconnect hoses from both ends of air regulator, and visually check to see if air regulator shutter opens.

3. Disconnect electric connector of air regulator, and check continuity. Continuity should exist. If not, air regulator is faulty.

Test No. 2 Air regulator power circuit				
Tester	Leads to Pins		Notes	Should Read
Voltmeter	(+)	(-)	1. Disconnect starter motor "S" terminal. 2. Connect battery ground cable. 3. Ignition "START"	Battery voltage
	108	Body ground		

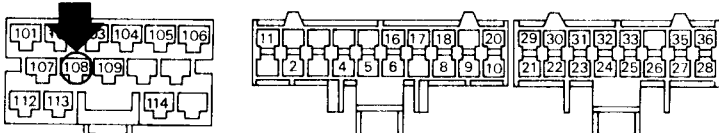

SEF512A

If test is O.K., air regulator is O.K.

If test is not O.K., listen for operating sound of fuel pump.

If no sound is heard with ignition "ON", check fuel pump relay.

If fuel pump operates with ignition "ON", check air regulator.

Fuel pump operates for 5 seconds with ignition "ON" when engine is not running.

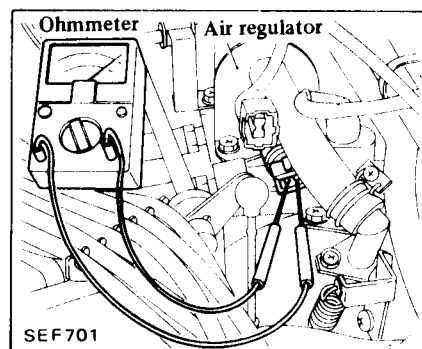

4. Pry air regulator shutter to open with a flat-blade screwdriver, then close. If shutter opens and closes smoothly, it is operating properly.

If test is O.K., check harness.

If test is not O.K., replace component and retest.

CHECKING FUEL PUMP RELAY

The fuel pump relay is installed on the dash right side.

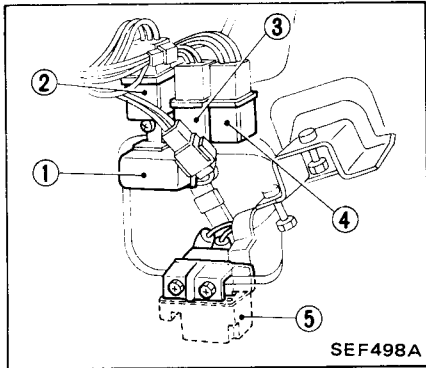

- 1 Seat belt warning timer unit
- 2 Fuel pump relay
- 3 Ignition relay
- 4 Accessory relay
- 5 Fan motor timer unit

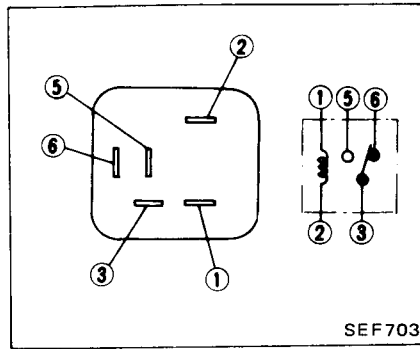

Check terminals	Normal condition	12V direct current is applied between terminals ① and ②
① - ②	Continuity	—
③ - ⑤	No continuity	Continuity
③ - ⑥	Continuity	No continuity

If test is O.K., check harness.
If test is not O.K., replace relay and retest.

INJECTOR CIRCUIT TESTS

Test No. 1 Cylinder No. 1			
Tester	Leads to Pins		Notes
Voltmeter	(+)	(-)	1. Connect battery ground cable. 2. Ignition "ON".
	101	Body ground	

SEF515A

If test is O.K., go to Test No. 2.

If test is not O.K., go to Component Check.

Test No. 2 Cylinder No. 2 or No. 3			
Tester	Leads to Pins		Notes
Voltmeter	(+)	(-)	Ignition "ON".
	102	Body ground	

SEF516A

If test is O.K., go to Test No. 3.

If test is not O.K., perform component check.

Test No. 3 Cylinder No. 3 or No. 2			
Tester	Leads to Pins		Notes
Voltmeter	(+)	(-)	Ignition "ON"
	103	Body ground	

SEF517A

If test is O.K., go to Test No. 4.

If test is not O.K., go to Component Check.

Component check

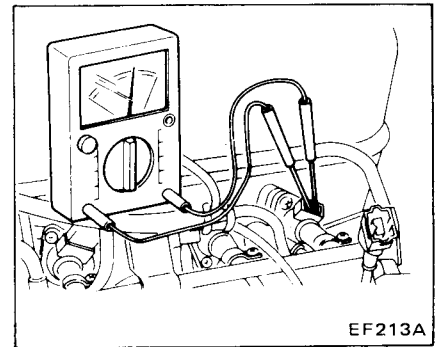

1. Disconnect ground cable from battery.
2. Disconnect electric connectors from injectors.
3. Check continuity between the two terminals. Continuity should exist. If not, injector(s) are faulty.

If test is O.K., go to E.C.C.S. harness Check.

If test is not O.K., replace injection.

Test No. 4 Cylinder No. 4, No. 5 or No. 6			
Tester	Leads to Pins		Notes
Voltmeter	(+)	(-)	Ignition "ON".
	104	Body ground	

SEF518A

If test is O.K., go to Test No. 5.

If test is not O.K., go to Component Check.

Test No. 5 Cylinder No. 5, No. 4 or No. 6			
Tester	Leads to Pins		Notes
Voltmeter	(+)	(-)	Ignition "ON".
	105	Body ground	

SEF519A

If test is O.K., go to Test No. 6.

If test is not O.K., go to Component Check.

Test No. 6 Cylinder No. 6, No. 4 or No. 5			
Tester	Leads to Pins		Notes
Voltmeter	(+)	(-)	Ignition "ON".
	106	Body ground	

SEF520A

If test is O.K., all injectors are O.K.

If test is not O.K., perform E.C.C.S. harness check.

E.F.I. RELAY

Component check

E.F.I. relay test (Control unit power input circuit test)

Tester	Leads to Pins		Notes	Should Read
Voltmeter	(+)	(-)	1. Connect battery ground cable. 2. Ignition "ON".	Battery voltage
	35	Body ground		

SEF521A

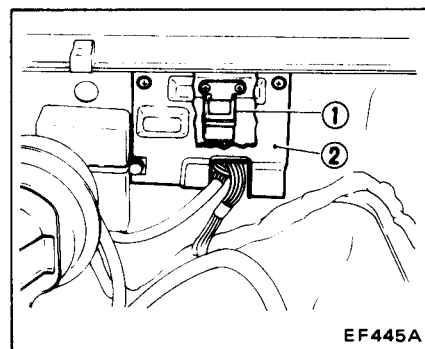

1 E.F.I. relay
2 Relay cover

If test is O.K., E.F.I. relay is O.K.

If test is not O.K., perform component check.

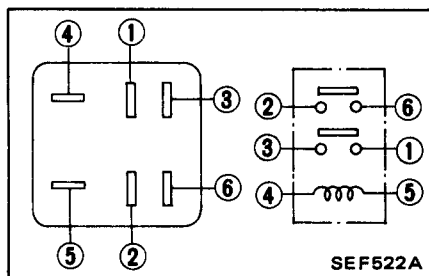

Check terminals	Normal condition	12V direct current is applied between terminals ④ and ⑤
④ - ⑤	Continuity	—
① - ③	No continuity	Continuity
② - ⑥	No continuity	Continuity

If test is O.K., check harness. If test is not O.K., replace relay and retest.

IGNITION START SIGNAL TEST

Ignition start signal test

Tester	Leads to Pins		Notes	Should Read
Voltmeter	(+)	(-)	1. Disconnect starter motor "S" terminal. 2. Connect battery ground cable. 3. Ignition "START".	Battery voltage
	9	Body ground		

SEF523A

If test is O.K., ignition start signal is O.K.

If test is not O.K., inspect ignition coil and harness.

VACUUM CONTROL MODULATOR (V.C.M.) TEST

Test No. 1 Solenoid valve for I.S.C.

Tester	Leads to Pins		Notes	Should Read
Voltmeter	(+)	(-)	1. Connect battery ground cable. 2. Ignition "ON".	Battery voltage
	2	Body ground		

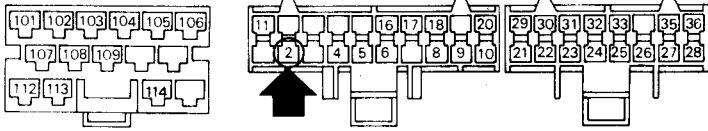

SEF524A

If test is O.K., go to Test No. 2.
If test is not O.K., check solenoid valve for I.S.C.

Test No. 2 Solenoid valve for E.G.R.

Tester	Leads to Pins		Notes	Should Read
Voltmeter	(+)	(-)	1. Connect battery ground cable. 2. Ignition "ON".	Battery voltage
	4	Body ground		

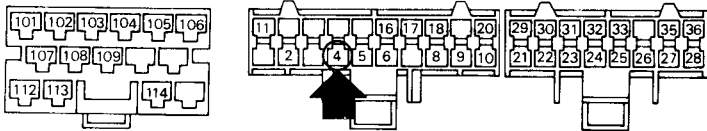

SEF525A

If test is O.K., solenoid valves of V.C.M. are O.K.
If test is not O.K., go to Component Check and Harness Check.

Component check

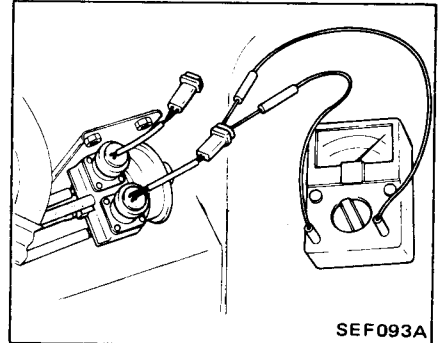

SEF093A

1. Disconnect two electric connectors from V.C.M.
2. Check resistance between two terminals. Resistance should be approximately 40 ohms. ... O.K.

If test is O.K., go to Harness Check.
If test is not O.K., replace V.C.M. assembly.

PARK/NEUTRAL SWITCH

Park/neutral switch test				
Tester	Leads to Pins		Notes	Should Read
	(+)	(-)		
Voltmeter	10	Body ground	1. Connect battery ground cable. 2. Ignition "ON". 3. Transmission gear position "N" or "P".	0V

SEF526A

If test is O.K., the park/neutral switch is O.K.

If test is not O.K., check harness and/or inhibitor switch. (Refer to AT section.)

AIR CONDITIONER SWITCH

Air conditioner switch				
Tester	Leads to Pins		Notes	Should Read
	(+)	(-)		
Voltmeter	22	Body ground	Air conditioner switch "ON" "OFF"	12V 0V

SEF527A

If test is O.K., the air conditioner switch is O.K.

If test is not O.K., check harness and/or air conditioner switch. (Refer to HA section.)

CRANKCASE EMISSION CONTROL SYSTEM

DESCRIPTION

MODEL NOT EQUIPPED WITH TURBOCHARGER

This system returns blow-by gas to both the intake manifold and air duct.

The positive crankcase ventilation (P.C.V.) valve is provided to conduct crankcase blow-by gas to the intake manifold.

During partial throttle operation of the engine, the intake manifold sucks the blow-by gas through the P.C.V. valve.

Normally, the capacity of the valve is sufficient to handle any blow-by and a small amount of ventilating air.

The ventilating air is then drawn from the air duct, through the tube connecting air duct to the rocker cover, into the crankcase.

Under full-throttle condition, the manifold vacuum is insufficient to draw the blow-by flow through the valve, and its flow goes through the tube connection in the reverse direction.

On cars with an excessively high blow-by, some of the flow will go through the tube connection to air duct under all conditions.

MODEL EQUIPPED WITH TURBOCHARGER

This system returns blow-by gas to both the suction hose and the intake manifold.

Since a vacuum is normally kept in the portion between the air cleaner and suction hose, blow-by gas in the rocker cover is sucked into the turbocharger from the suction hose, and is then sent into the intake chamber where it is burnt in the engine.

Blow-by gas located in the crankcase flows into the intake manifold through the positive crankcase ventilation (P.C.V.) valve in the blow-by lower hose when vacuum is maintained in the intake manifold. If positive pressure exists in the intake manifold, any blow-by gas in the crankcase is led to the blow-by upper hose, which prevents an abnormal rise in crankcase pressure.

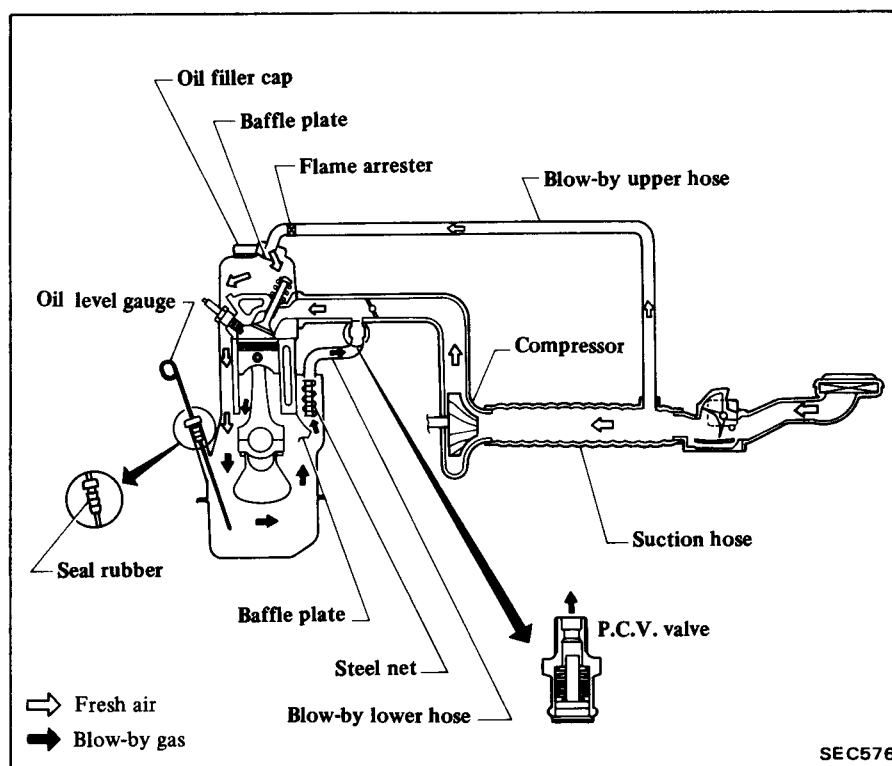
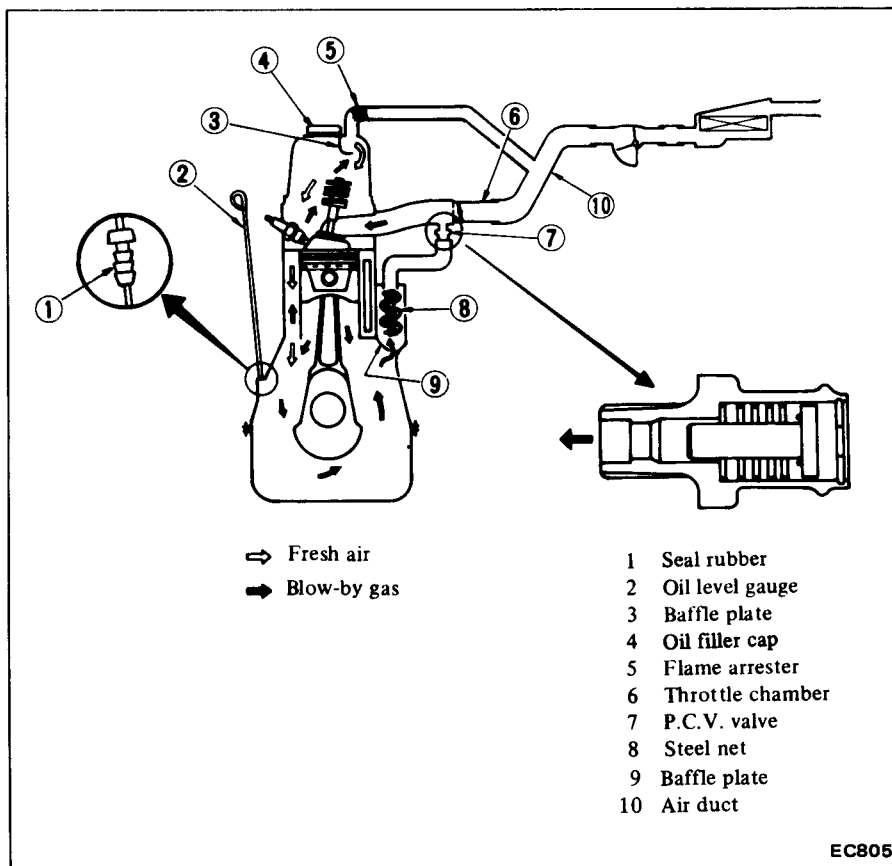

INSPECTION

P.C.V. VALVE

With engine running at idle, remove the ventilation hose from P.C.V. valve. If the valve is working, a hissing noise will be heard as air passes through the valve and a strong vacuum should be felt immediately when a finger is placed over valve inlet.

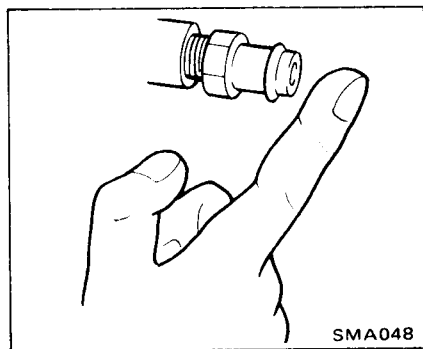

VENTILATION HOSES

1. Check hoses and hose connections for leaks.
2. Disconnect all hoses and clean with compressed air.

If any hose cannot be freed of obstructions, replace.

Ensure that flame arrester is surely inserted in hose between air duct and rocker cover.

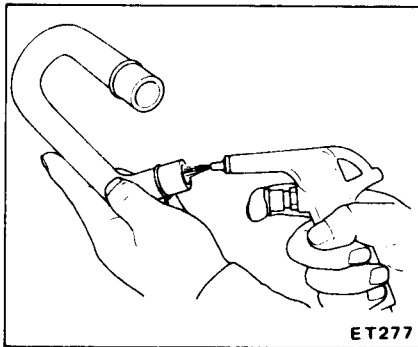

EXHAUST EMISSION CONTROL SYSTEM

EXHAUST GAS RECIRCULATION (E.G.R.) SYSTEM

OPERATION

In the exhaust gas recirculation system, some of the exhaust gas is returned to the combustion chamber to lower the spark flame temperature

during combustion. This results in a reduction of the nitrogen oxide content in the exhaust gas.

When the E.G.R. control valve is open, some of the exhaust gas is led from the exhaust manifold to the chamber.

The exhaust gas is then regulated by E.G.R. valve, and is introduced into the intake manifold.

Water temperature °C (°F)	Thermal vacuum valve	E.G.R. Control system
Below 55 (131)	Open	Not actuated
55 - 95 (131 - 203)	Closed	Actuated
Above 95 (203)	Open	Not actuated

With the engine at idle or at full throttle, the E.G.R. control valve closes to deactivate the E.G.R. system regardless of water temperature.

E.G.R. control valve

The E.G.R. control valve controls the quantity of exhaust gas to be led to the intake manifold through vertical movement of the taper valve connected to the diaphragm, to which vacuum is applied in response to the opening of the throttle valve.

When replacing the E.G.R. valve with a new one, verify that the type

number on the new part is the same as that on the former one.

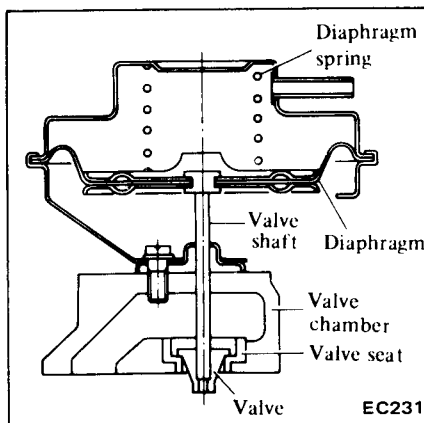

Thermal vacuum valve (3-port wax type)

The thermal vacuum valve, which is attached to the thermostat housing, monitors the temperature of the engine cooling water. The valve shaft is propelled by the thermal expansion force of wax which depends on the temperature. This action opens and closes the valve, which causes the E.G.R. control vacuum line to be exposed or closed to the atmosphere. When the valve opens, air from the air pipe line is introduced, and because the venturi vacuum transducer (V.V.T.) valve and E.G.R. valve diaphragm are exposed to the atmosphere the E.G.R. operation will not function.

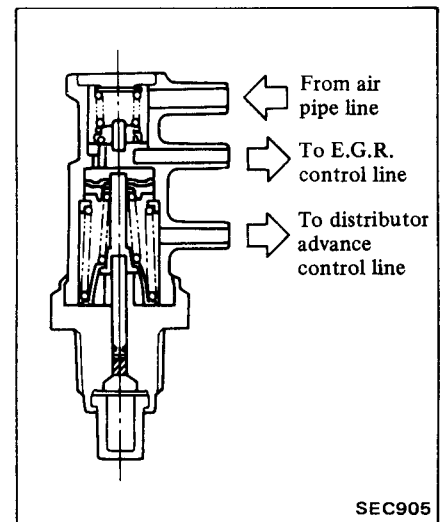

- a. Be sure to apply sealer to threads of the valve prior to installing a new valve.
- b. When installing a new thermal vacuum valve, be sure that color and shape are correct.

INSPECTION

Entire system

1. Make a thorough visual check of E.G.R. control system. If necessary, wipe away oil to facilitate inspection.

If any hoses are cracked or broken, replace.

2. With engine stopped, inspect E.G.R. control valve for any indication of binding or sticking by moving diaphragm of control valve upwards with finger.

3. With engine running, inspect E.G.R. control valve. Place a finger on the diaphragm of E.G.R. control valve to check for valve operation.

Check operation of E.G.R. valve, using the following chart as a guide. Engine speed should always be increased from idle to 3,000 to 3,500 rpm.

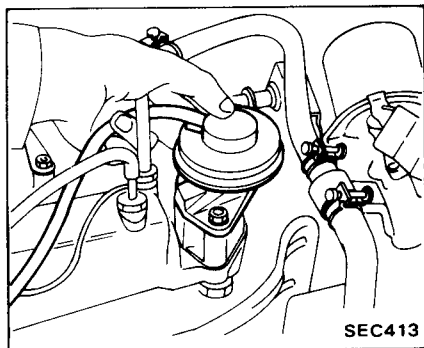

Engine coolant temperature °C (°F)	E.G.R. control valve operation
Below 55 (131) or above 95 (203)	Not actuated
55 - 95 (131 - 203)	Actuated

4. If E.G.R. control valve does not operate as indicated above, check as follows:

- Engine coolant temperature is between 55 and 95°C (131 and 203°F)

- Increase engine speed from idle to 3,000 to 3,500 rpm.

(1) Thermal vacuum valve.

- Disconnect one end of vacuum gallery.

- Make sure that thermal vacuum valve is closed, and that throttle chamber vacuum is not present at end of vacuum tube.

- If vacuum is present, check thermal vacuum valve itself.

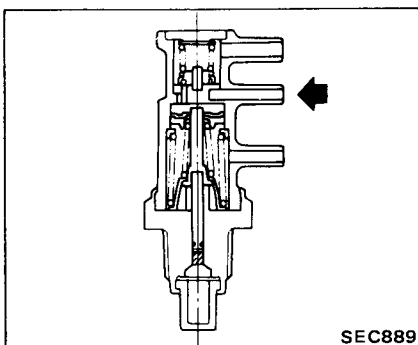

(2) E.G.R. control valve.

Check E.G.R. control valve itself.

Thermal vacuum valve

Remove thermal vacuum valve from engine. Inhale air from port of spark timing control system and check to be sure that thermal vacuum valve opens or closes in response to its temperature.

Thermal vacuum valve operating temperature:

Operating temperature °C (°F)	
Open	Closed
Below 55 (131)	55 - 95
Above 95 (203)	(131 - 203)

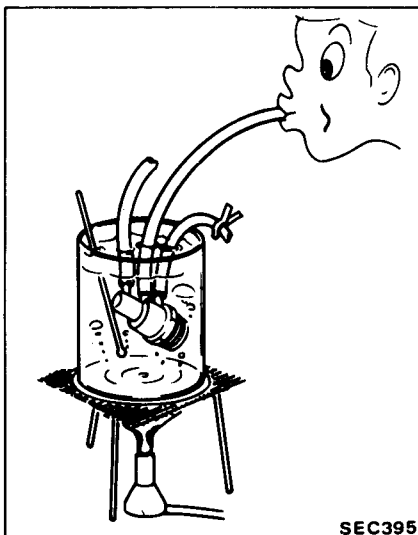

CAUTION:

Do not allow water to get inside the thermal vacuum valve.

E.G.R. control valve

Dismount E.G.R. control valve from engine.

1. Apply vacuum to E.G.R. control valve, referring to the following figure. If the valve moves to full position, it is normal.

Plug hose with vacuum applied.

E.G.R. control valve will remain open for more than 30 seconds after vacuum has cut off.

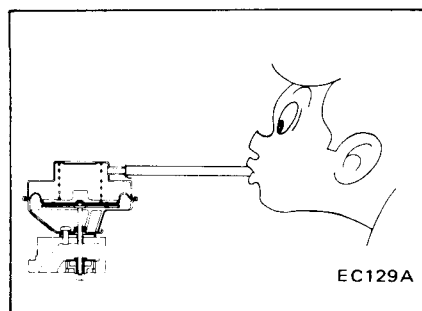

2. Visually check E.G.R. control valve for damage, wrinkle or deformation.

SPARK TIMING CONTROL SYSTEM

VACUUM ADVANCE MECHANISM

Description

The spark timing is controlled in two stages, WARM-UP and NORMAL DRIVING to obtain good fuel economy and quick warm-up of the catalyst.

This system is designed so that the engine coolant temperature is monitored by the T.V.V. to control the distributor vacuum and provide correct advance timing.

Operation

This system is controlled as follows:

	Warm-up	Normal driving
Water temperature °C (°F)	Below 55 (131)	Above 55 (131)
Spark timing control system	Not actuated	Actuated

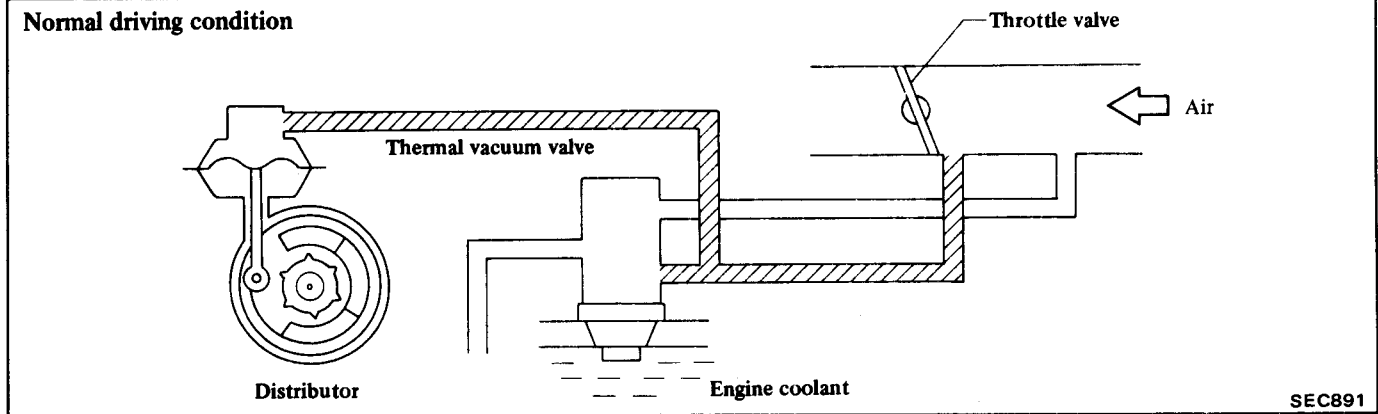
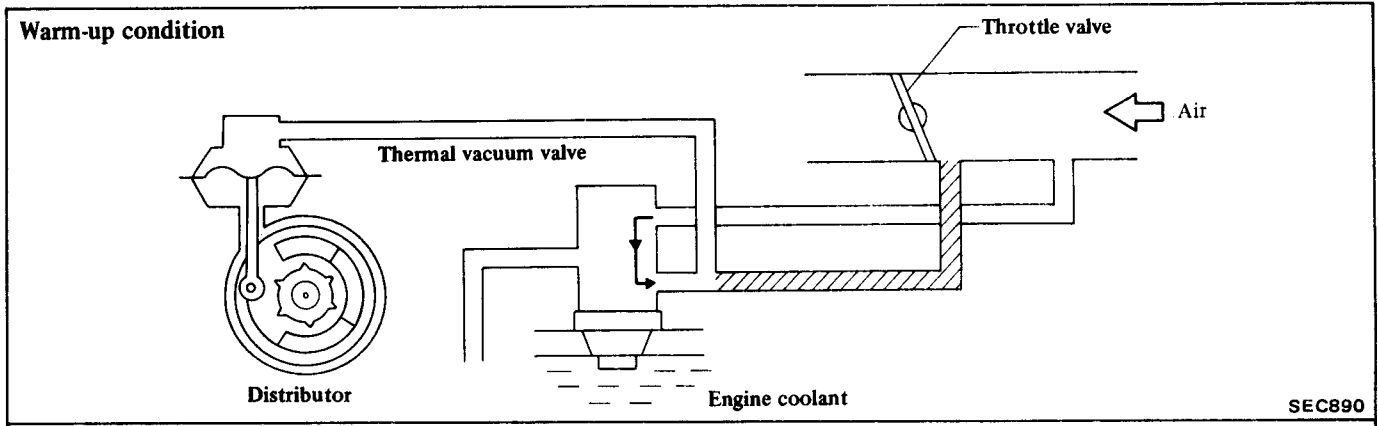

Thermal vacuum valve

The thermal vacuum valve designs are exactly the same as those used in the E.G.R. control system. This action opens and closes the valve, which causes the spark timing control vacuum line to be exposed or closed to the atmosphere.

The thermal valve opens and closes to either permit or obstruct external air passing to the distributor vacuum line. When the valve opens, the vacuum signal line will allow external air to enter, thereby stopping the distributor vacuum from advancing.

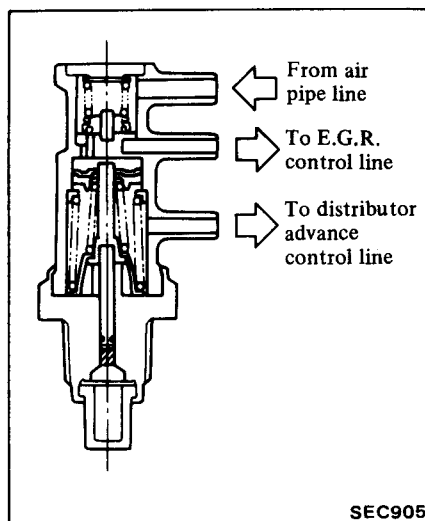

Inspection

Entire system

1. Disconnect harness connector (Color: Gray) from distributor.

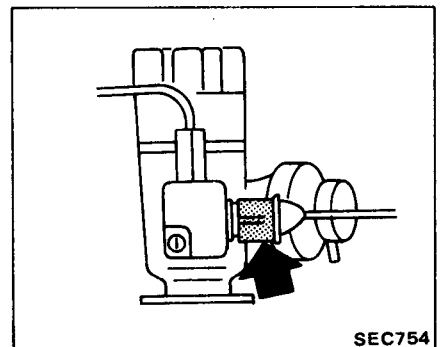

2. Ensure that vacuum hoses are properly connected to their positions.
3. Ensure that distributor vacuum controller properly functions.
4. Set timing light.
5. Check thermal vacuum valve as follows:

Start the engine from the cold condition.

- (1) Using timing light, check the spark timing when the temperature gauge is in the C-position.

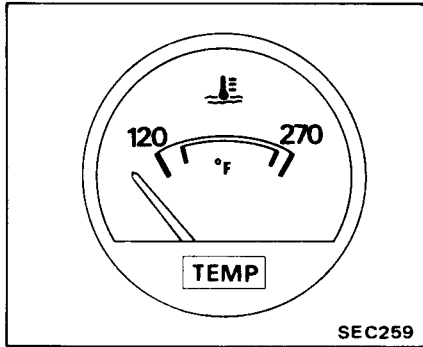

- (2) Warm up the engine to the middle position of temperature gauge.

Ensure that the spark timing advances from the former condition.

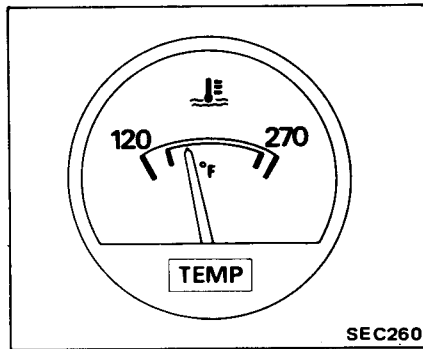

If the spark timing does not change, check thermal vacuum valve.

Check proper operation of thermal vacuum valve as follows:

Thermal vacuum valve

Thermal vacuum valve operating temperature:

Operating temperature °C (°F)	
Open	Closed
Below 55 (131)	Above 55 (131)

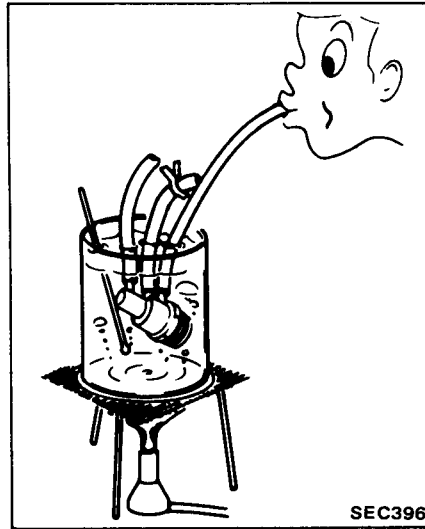

CAUTION:

Do not allow water to get inside the thermal vacuum valve.

ELECTRIC ADVANCE SYSTEM

Description

The spark timing is controlled by means of electric method, only when the engine condition is either "Cold" (the coolant is below certain temperature) or "Idle" (the throttle valve is closed), the spark timing is advanced.

Operation

This system is controlled as follows:

	Idle condition (Idle switch: ON)	Other condition (Idle switch: OFF)
Cold condition (Water temperature switch: ON)	Advanced	Advanced
Normal condition (Water temperature switch: OFF)	Advanced	Not advanced

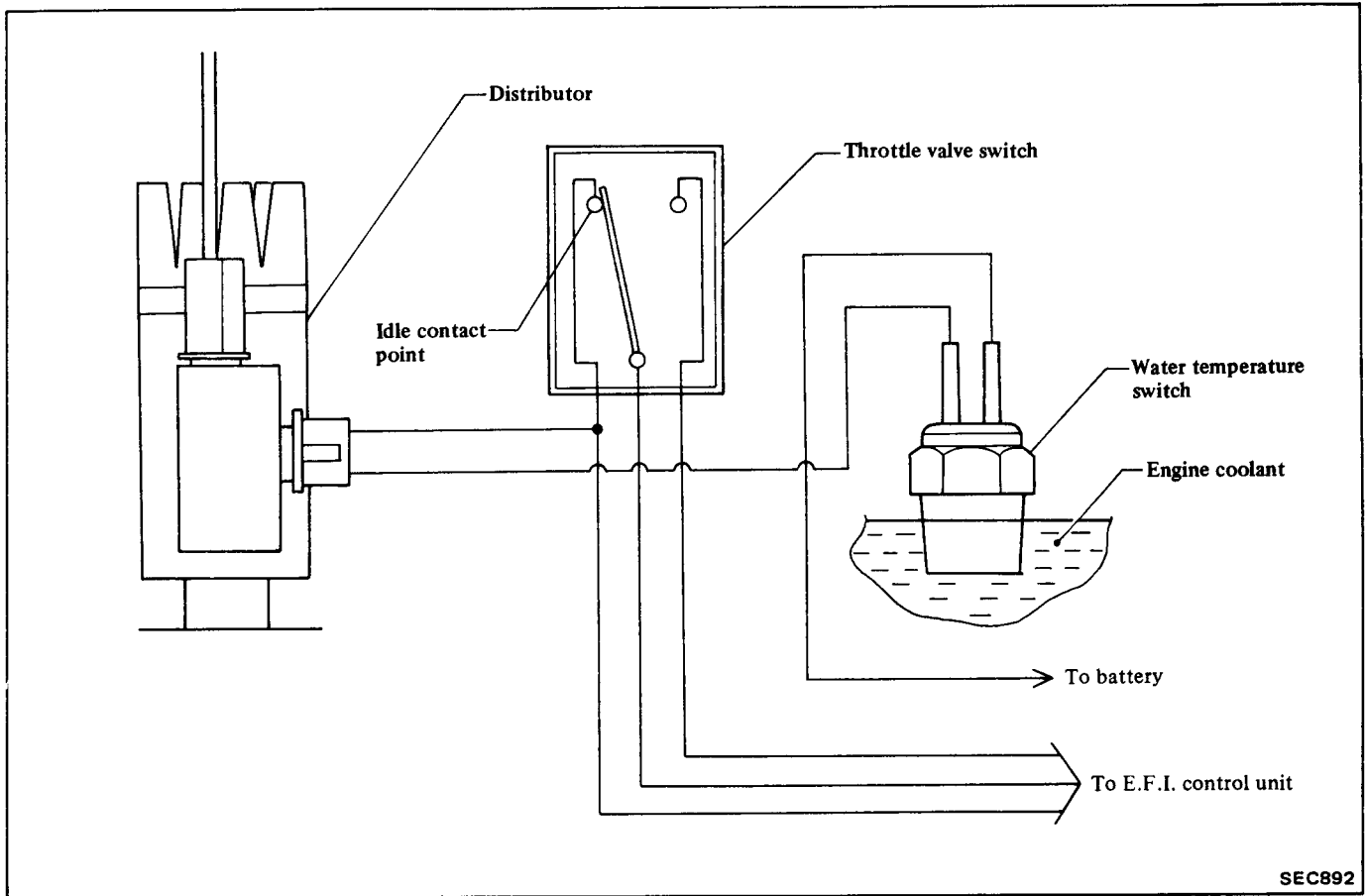

SEC892

Water temperature switch

Water temperature switch is operated by coolant temperature as shown below.

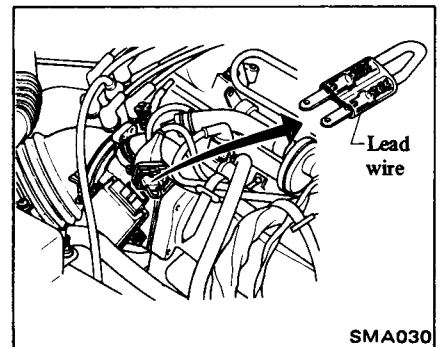
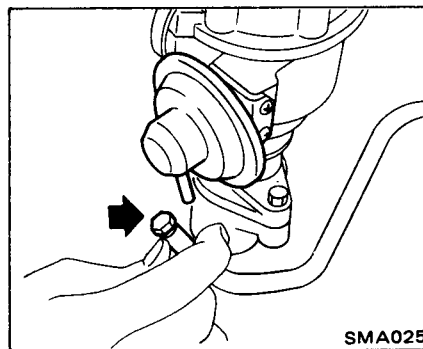
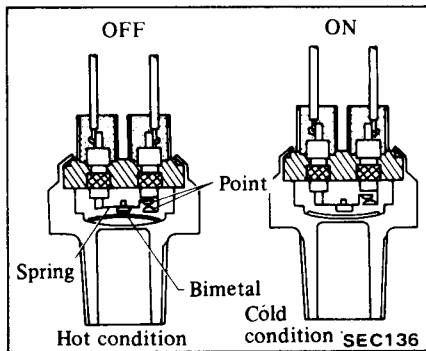

- (1) Start the engine from the cold condition.
- (2) Using timing light, check the spark timing when the temperature gauge is in the C-position.

Inspection

Entire system

1. Disconnect distributor vacuum hose from distributor vacuum controller, and plug hose with proper plug.

2. Ensure that harness connectors are properly connected to their positions.
3. Set timing light.
4. Check the system operation as follows:

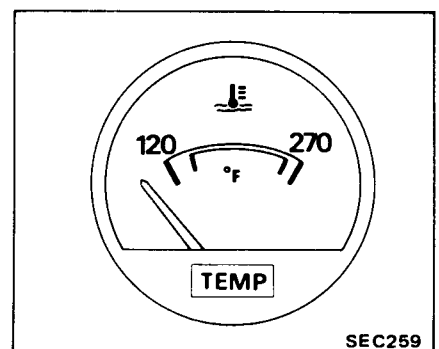

(3) Stop the engine and disconnect the lead wire between terminals No. 24 and No. 30 of throttle valve switch harness connector.

(4) Using timing light, recheck the spark timing when the temperature gauge is in the C-position. Make sure that it indicates the same spark timing as that shown in step (2).

(5) Using timing light, ensure that the spark timing retards from the former condition when the temperature gauge changes from the C-position to the middle position.

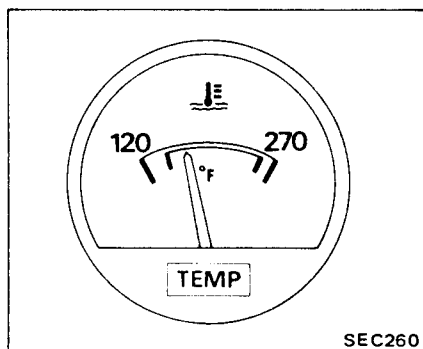

(6) Stop the engine and connect throttle valve switch harness connector.

(7) Ensure that the spark timing advances from the former condition.

(8) If the spark timing shows abnormalities in the above steps, check throttle valve switch and water temperature switch.

Check proper operation of water temperature switch as follows.

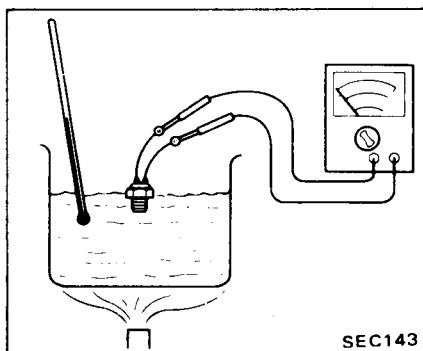

Water temperature °C (°F)	Continuity
Below 35 (95)	Yes
Above 35 (95)	No

There are two diaphragms in the device unit. Diaphragm I detects the manifold vacuum and makes the Vacuum Control Valve open when the vacuum exceeds the operating pressure. Diaphragm II operates the Air Control Valve according to the vacuum transmitted through the Vacuum Control Valve. The Air Control Valve regulates the amount of additional air so that the manifold vacuum can be kept at the proper operating pressure. The operating pressure changes depending on altitude; thus, diaphragm I and control valve operations are adjusted automatically in coincidence with the altitude at which the vehicle is driven. The table indicates change in operating pressure for changes in atmospheric pressure and altitude.

OPERATION

B. C. D. D.

Diaphragm I ⑤ monitors the manifold vacuum; when the vacuum exceeds a pre-determined value, it acts so as to open the vacuum control valve ④. This causes the manifold vacuum to be introduced into vacuum chamber II ⑬ and actuates diaphragm II ⑦.

When diaphragm II operates, the air control valve ⑧ opens the air passage and introduces the additional air into the manifold.

The amount of air is controlled by the servo-action of the air control valve ⑧ and vacuum control valve ④ so that the manifold vacuum may be kept at the pre-determined value.

BOOST CONTROLLED DECELERATION DEVICE (B.C.D.D.)

DESCRIPTION

The Boost Controlled Deceleration Device (B.C.D.D.) is employed to reduce HC emissions emitted during coasting. The B.C.D.D., installed under the intake manifold supplies additional air to the intake manifold during coasting to maintain the manifold vacuum at the proper operating pressure.

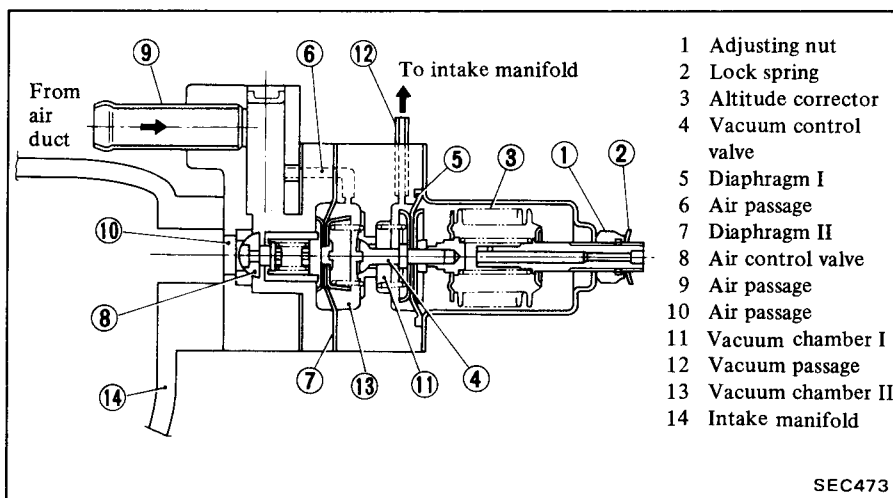

- 1 Adjusting nut
- 2 Lock spring
- 3 Altitude corrector
- 4 Vacuum control valve
- 5 Diaphragm I
- 6 Air passage
- 7 Diaphragm II
- 8 Air control valve
- 9 Air passage
- 10 Air passage
- 11 Vacuum chamber I
- 12 Vacuum passage
- 13 Vacuum chamber II
- 14 Intake manifold

Water temperature switch

1. Drain about one liter (1-1/8 US qt, 7/8 Imp qt) of engine coolant.
2. Disconnect wiring. Do not attach tool to the plastic portion of switch, because that could break the switch.
3. Dip the switch in a pan of water, and check its responses to changes in water temperature.

INSPECTION

Entire system

Generally, it is unnecessary to adjust the boost control valve. If it should become necessary to adjust it, the procedure is as follows:

This adjustment should be carried out with the automatic transmission lever in the "N" position.

Prepare the following tools

- (1) Tachometer to measure the engine speed while idling.
- (2) A vacuum gauge and connecting pipe.

1. Connect rubber hose between vacuum gauge and intake manifold as shown.

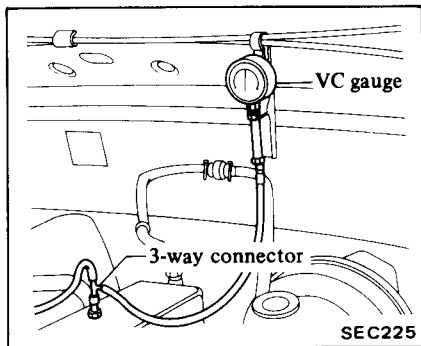

2. Warm up the engine until it is heated to operating temperature.

Then adjust the engine at normal idle setting. (Refer to the item "Idle Adjustment").

3. Run the engine under no load. Increase engine speed to 3,000 to 3,500 rpm, then quickly close throttle valve.

4. At that time, the manifold vacuum pressure will change as follows:

- 1) It will abruptly rise up to -80.0 kPa (-600 mmHg, -23.62 inHg) or above.
- 2) It will decrease gradually to a certain level and stay there for a while. This is so called operating pressure.
- 3) In most cases, it will drop to idling pressure.

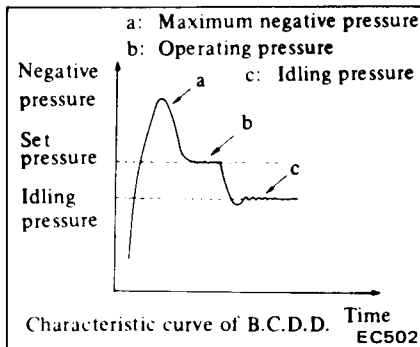

5. Check that the B.C.D.D. operating pressure is within the specified range.

Unit: kPa (mmHg, inHg)

At atmospheric pressure	Operating pressure
101.3 (760, 29.92)	-76.0 ± 2.7 (-570 ± 20 , -22.44 ± 0.79)
80.0 (600, 23.62)	-58.7 ± 2.7 (-440 ± 20 , -17.32 ± 0.79)

6. If it is lower or higher than the specified level, turn the adjusting screw in the following direction until correct adjustment is made.

Adjusting screw:

- Lower condition
Counterclockwise
- Higher condition
Clockwise

8. If it is lower than the set level, turn the adjusting screw until correct adjustment is made.

9. Race the engine and check for adjustment.

If engine speed cannot be decreased to idling when checking B.C.D.D. operating pressure, proceed as follows.

- 10. (1) Turn adjusting screw counterclockwise so that B.C.D.D. operating pressure is on high vacuum side, 2.7 kPa (20 mmHg, 0.79 inHg) away from the specified value.

- (2) Turn adjusting screw $1/4$ of a turn clockwise so that B.C.D.D. operating pressure drops by 2.7 kPa (20 mmHg, 0.79 inHg).

If B.C.D.D. operating pressure cannot be observed clearly even in step 10 (1), proceed as follows:

- 11. (1) Turn adjusting screw counterclockwise so that B.C.D.D. operating pressure is on the high vacuum side 6.7 kPa (50 mmHg, 1.97 inHg) away from the specified value.

- (2) Turn the adjusting screw $1/2$ of a turn clockwise.

The B.C.D.D. operating pressure should be correctly set within the specified range after the above adjustments, even if the engine speed cannot be decreased to idling.

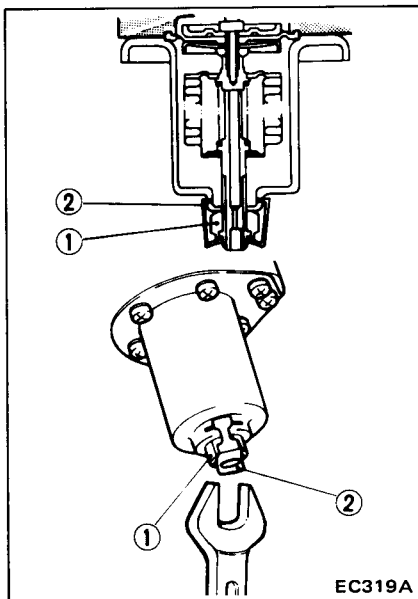

- 1 Adjusting nut
- 2 Lock spring

7. Race the engine and check for adjustment.

CATALYTIC CONVERTER SYSTEM

DESCRIPTION

The three-way catalytic converter utilizes a catalyst to accelerate the re-combustion of HC and CO and reduce NOx in the exhaust gas, changing them into harmless CO₂, H₂O and N₂.

To accomplish the oxidization and reduction of such harmful contents, the exhaust gas sensor monitors O₂ level, feeds it back to the EFI control unit and maintains the mixture ratio to the stoichiometric point at all times.

OPERATION

The exhaust gas from the engine contains unburned, harmful components. The mixture ratio feedback system reduces such harmful components in the exhaust gas. In this system, an exhaust gas sensor monitors the contents of O₂ density to determine the combustion condition and maintains the mixture ratio to the stoichiometric point.

While the mixture ratio is so maintained, the three-way catalytic converter activates to change the harmful components (HC, CO, and NOx) into harmless CO₂, H₂O and N₂. In this way, the catalytic converter cleans the exhaust gas and discharges H₂O, CO₂ and N₂ into the atmosphere.

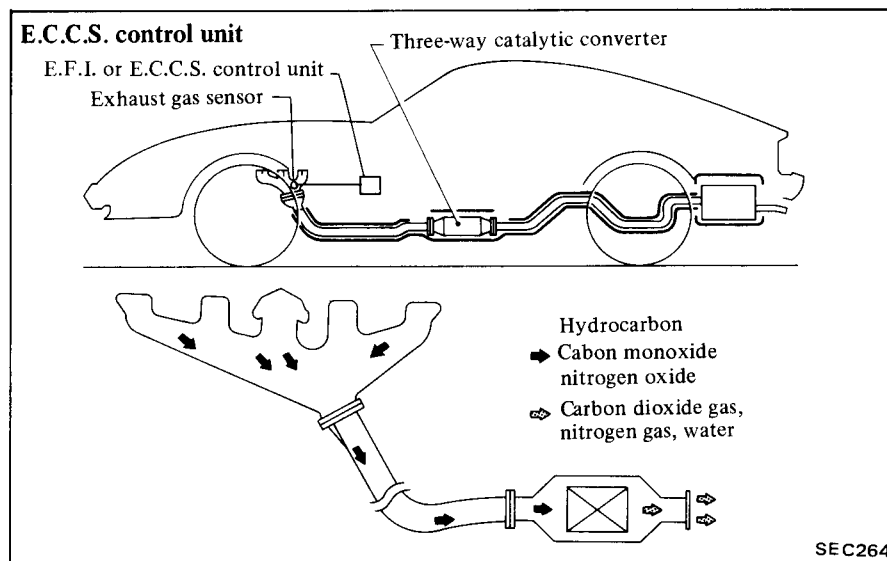

INSPECTION

Preliminary inspection

Visually check condition of all component parts including hoses, tubes, and wires, replace if necessary. Refer to Mixture Ratio Feedback System for inspection.

Catalytic converter

Check whether catalytic converter is normal or not by observing variation in CO percentage. The checking procedure is as follows:

Apply parking brake. Shift gears into "Neutral" (for manual transmission) and "N" or "P" (for automatic transmission) position.

E.F.I. models

1. Visually check catalytic converter for damage or cracks.
2. Adjust engine idle speed. Refer to Adjusting Idle RPM for adjustment.
3. Race engine (1,500 to 2,000 rpm) two or three times under no load.
4. If idle speed increases, readjust it to specified speed with throttle adjusting screw.
5. Warm up engine for about four minutes at 2,000 rpm under no load.

6. Measure CO percentage at idle speed. After step 5 has been completed, wait for one minute before making CO percentage measurement.
7. If CO percentage measured in step 6 is less than 0.3%, the catalytic converter is normal.
8. If CO percentage measured in step 6 is over 0.3%, check mixture ratio feedback system to see if it is functioning properly. Then, perform inspection steps 5 and 6.
9. If CO percentage is still over 0.3% in step 8, catalytic converter is malfunctioning. Replace catalytic converter.

E.C.C.S. models

Check whether catalytic converter is normal or not by observing variation in CO percentage. The checking procedure is as follows:

Apply parking brake. Shift gears into "N" or "P" position.

1. Visually check catalytic converter for damage or cracks.
2. Warm up engine for about four minutes at 2,000 rpm under no load.
3. Measure CO percentage at idle speed. After step 2 has been completed, wait for one minute before making CO percentage measurement.
4. If CO percentage measured in step 3 is less than 0.3%, the catalytic converter is normal.
5. If CO percentage measured in step 3 is over 0.3%, check mixture ratio feedback system to see if it is functioning properly. Then, perform inspection steps 2 and 3.
6. If CO percentage is still over 0.3% in step 5, catalytic converter is malfunctioning. Replace catalytic converter.

EVAPORATIVE EMISSION CONTROL SYSTEM

DESCRIPTION

The evaporative emission control system is used to reduce hydrocarbons

emitted to the atmosphere from the fuel system. This reduction of hydro-

carbons is accomplished by activated charcoals in the carbon canister.

E.F.I. MODELS

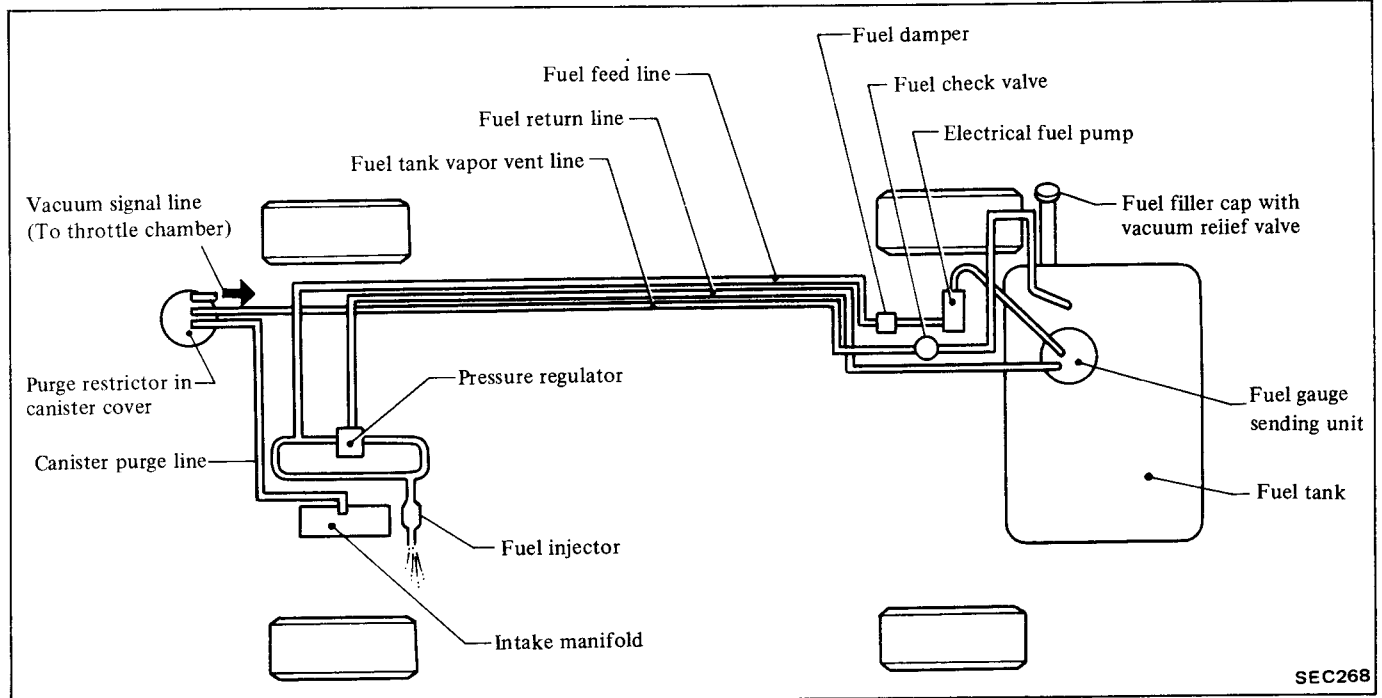

E.C.C.S. MODELS

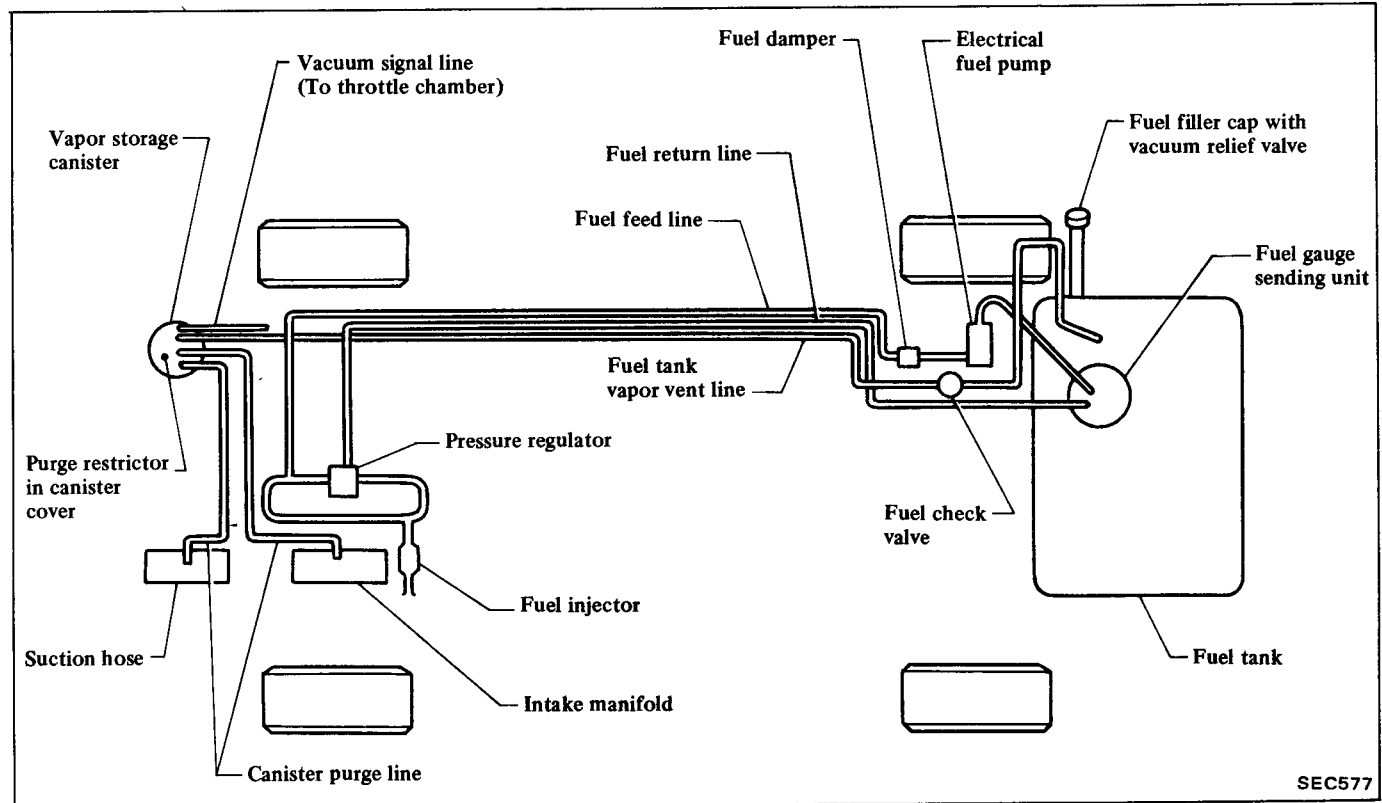

OPERATION

Fuel vapors from the sealed fuel

tank are led into the carbon canister, which is filled with activated char-

coals, and stored there when the engine is not running.

MODEL NOT EQUIPPED WITH TURBOCHARGER

Type-A

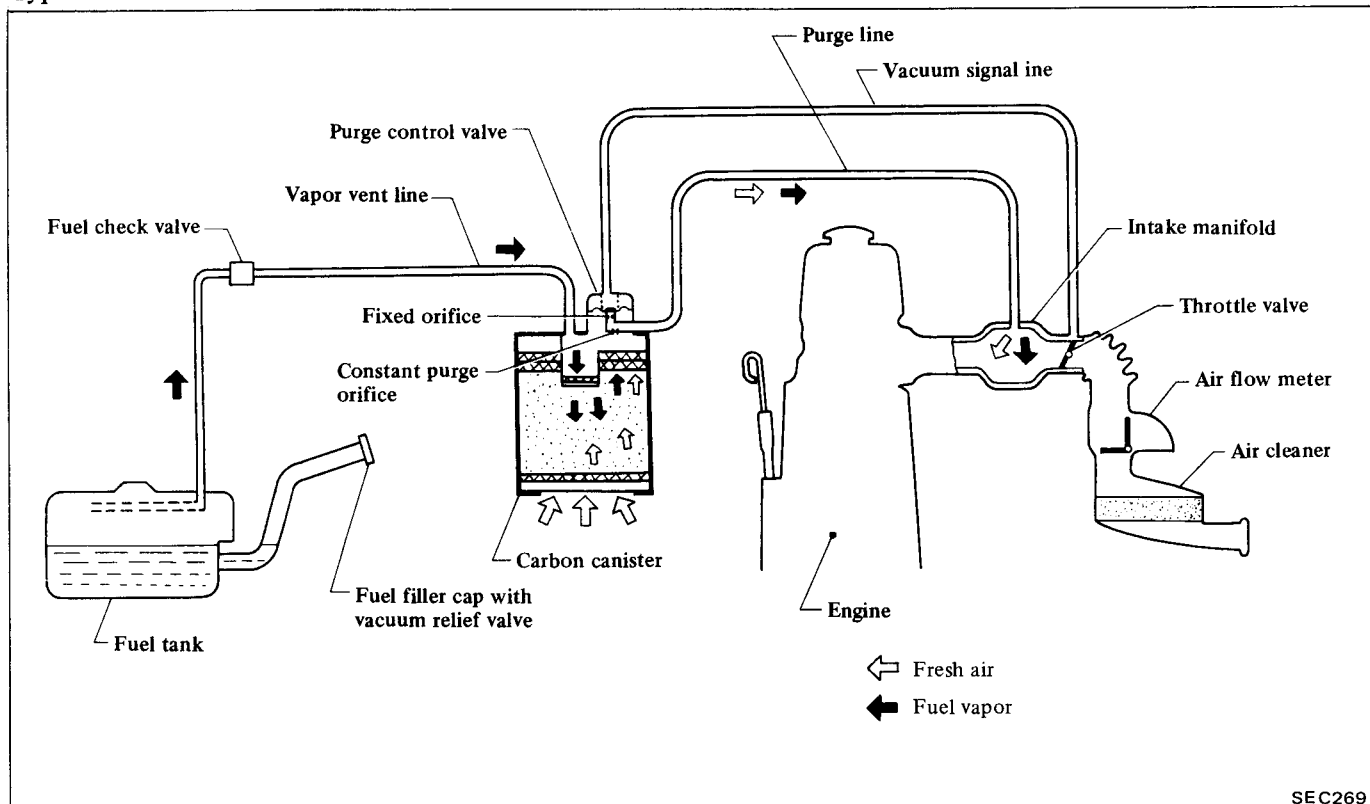

SEC269

The canister retains the vapor until the canister is purged by the air drawn through the purge line to the intake manifold when the engine is operated. When the engine runs at idle, the purge

control valve is closed. Only a small amount of purge air flows into the intake manifold through the constant purge orifice. As the engine speed increases, and the ported vacuum rises

higher, the purge control valve opens and the vapor is sucked into the intake manifold through both the fixed orifice and the constant purge orifice.

(1) Engine does not operate

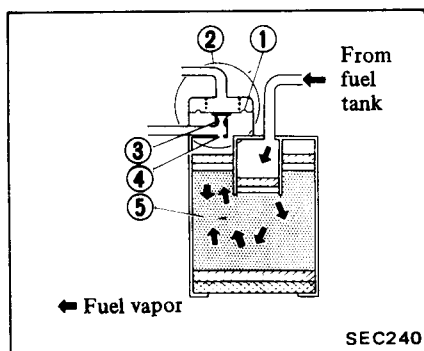

SEC240

- 1 Diaphragm
- 2 Purge control valve
- 3 Fixed orifice
- 4 Constant fixed orifice
- 5 Activated carbon

(2) Engine operates at idle

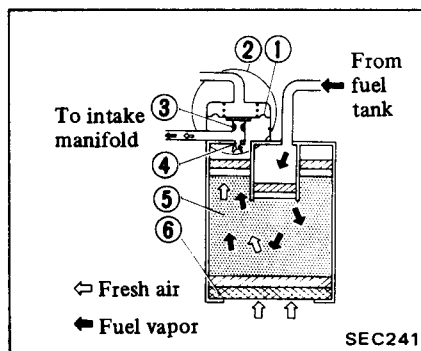

SEC241

- 1 Diaphragm
- 2 Purge control valve
- 3 Fixed orifice
- 4 Constant fixed orifice
- 5 Activated carbon
- 6 Filter

(3) Engine speed increases

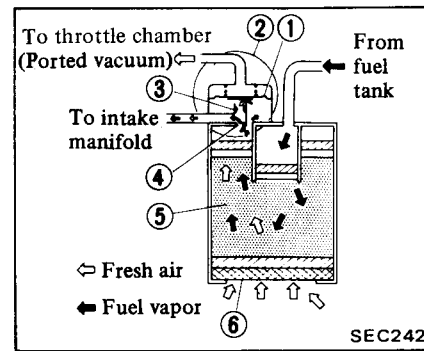

SEC242

- 1 Diaphragm
- 2 Purge control valve
- 3 Fixed orifice
- 4 Constant fixed orifice
- 5 Activated carbon
- 6 Filter

MODEL EQUIPPED WITH TURBOCHARGER

Type-B

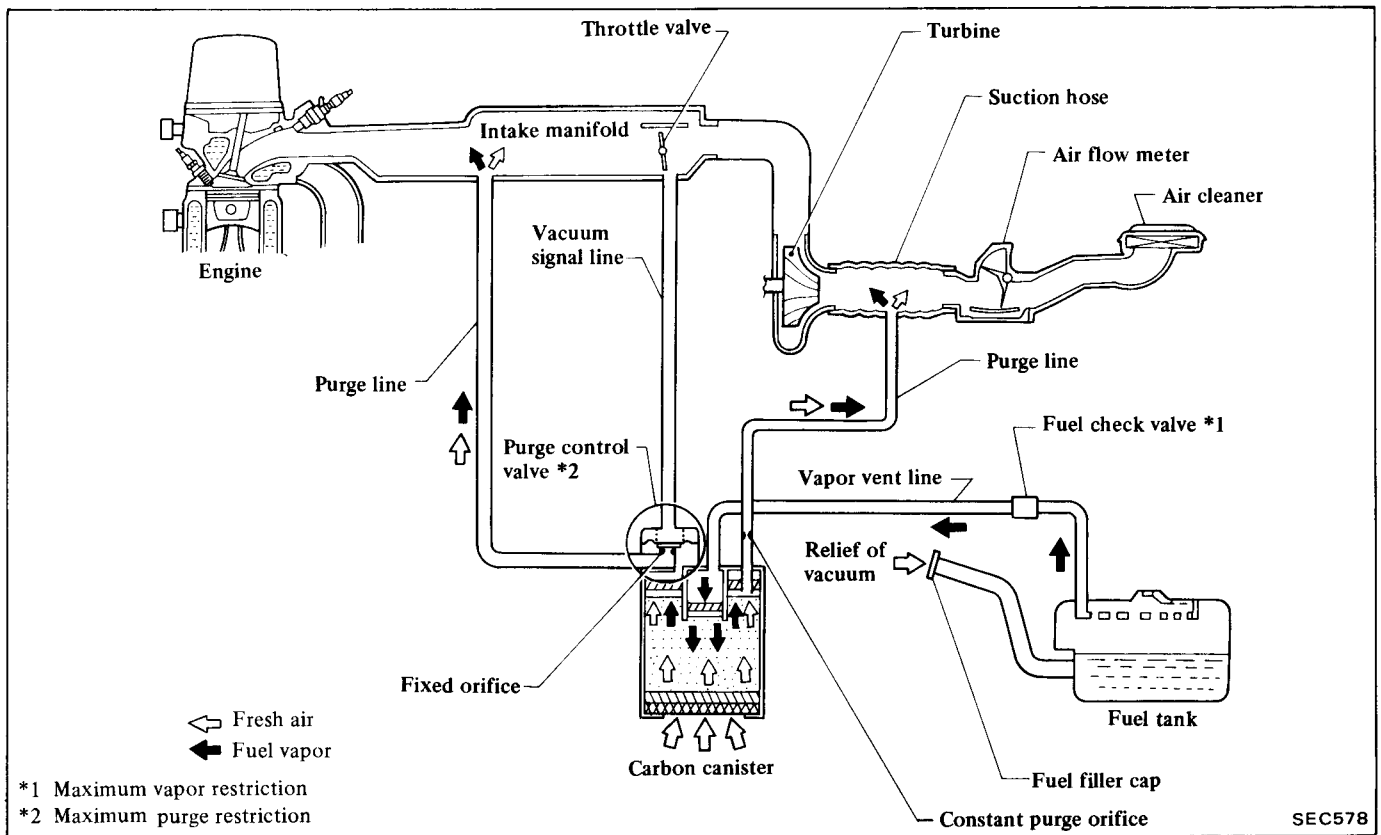

The canister retains the vapor until the canister is purged by the air drawn through the purge line to the intake manifold and the suction hose when the engine is operated. When the engine runs at idle, the purge control valve is closed. A small amount of

purge air flows into the suction hose through the constant purge orifice. As the engine speed increases, and the ported vacuum rises higher, the purge control valve opens and the vapor is sucked into the intake manifold and the suction hose through respectively

the fixed orifice and the constant purge orifice. When the engine stops and intake manifold pressure become atmospheric pressure, the purge control valve is closed, and the vapor is sucked only into the suction hose through the constant purge orifice.

(1) Engine runs at idle

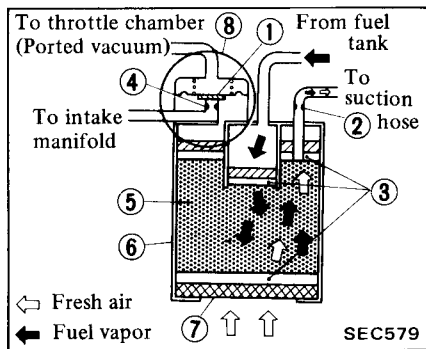

- 1 Diaphragm
- 2 Fixed orifice (Constant purge)
- 3 Filter
- 4 Fixed orifice
- 5 Activated carbon
- 6 Case
- 7 Filter
- 8 Purge control valve

(2) Engine speed increases

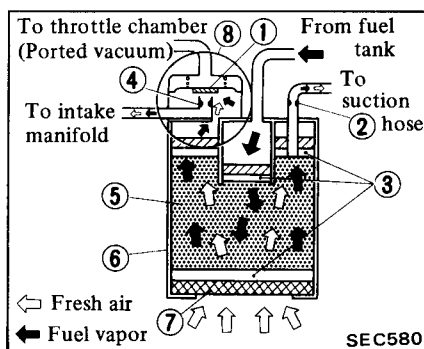

- 1 Diaphragm
- 2 Fixed orifice (Constant purge)
- 3 Filter
- 4 Fixed orifice
- 5 Activated carbon
- 6 Case
- 7 Filter
- 8 Purge control valve

(3) Engine stops

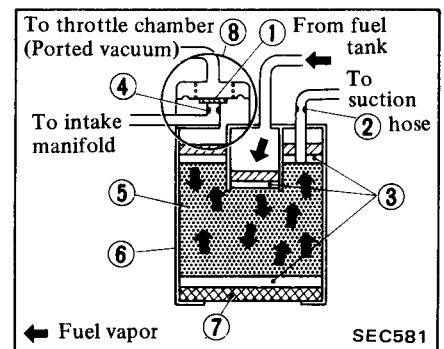

- 1 Diaphragm
- 2 Fixed orifice (Constant purge)
- 3 Filter
- 4 Fixed orifice
- 5 Activated carbon
- 6 Case
- 7 Filter
- 8 Purge control valve

INSPECTION

FUEL TANK AND VAPOR VENT LINE

1. Check all hoses and fuel tank filler cap.
2. Disconnect the vapor vent line connecting carbon canister to fuel tank.

3. Connect a 3-way connector, a manometer and a cock (or an equivalent 3-way charge cock) to the end of the vent line.
4. Supply fresh air into the vapor vent line through the cock little by little until pressure becomes 3.923 kPa (400 mmH₂O, 15.75 inH₂O).

5. Shut the cock completely and leave it unattended.
6. After 2.5 minutes, measure the height of the liquid in the manometer.
7. Variation in height should remain at 0.245 kPa (25 mmH₂O, 0.98 inH₂O).
8. When filler cap does not close completely, the height should drop to zero in a short time.
9. If the height does not drop to zero in a short time when filler cap is removed, the cause is a stuffy hose.

Model not equipped with turbocharger

Type-A

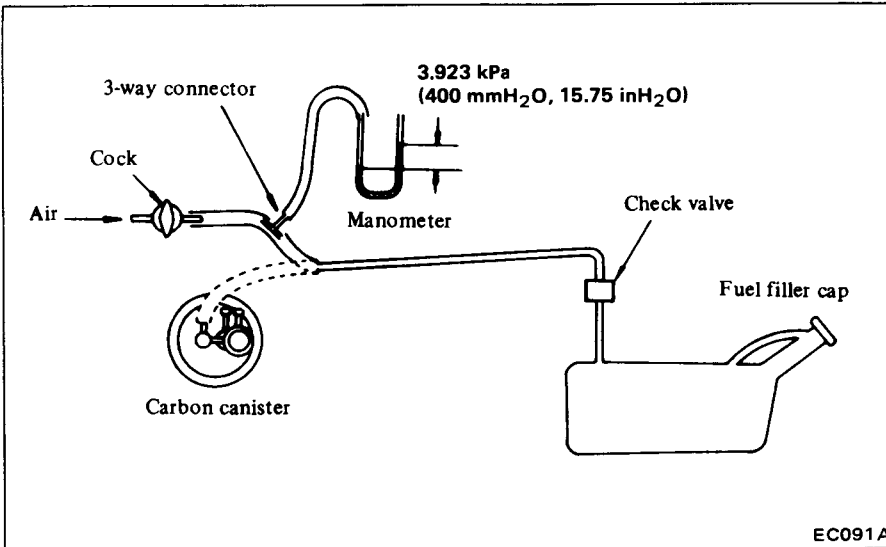

In case the vent line is stuffy the breathing in fuel tank is not thoroughly made thus causing insufficient deliver of fuel to engine or vapor lock. It must, therefore, be repaired or replaced.

CARBON CANISTER PURGE CONTROL VALVE

Check for fuel vapor leakage, in the vacuum line, at diaphragm of carbon canister purge control valve.

To check for leakage, proceed as follows:

1. Inhale air into the opening of rubber hose running to vacuum hole in carbon canister and ensure that there is no leak.

Model equipped with turbocharger

Type-B

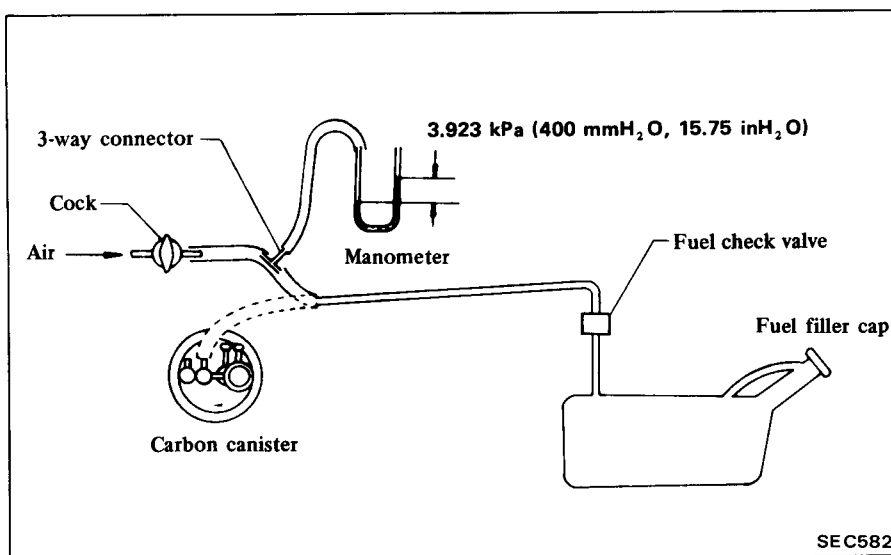

Type-A

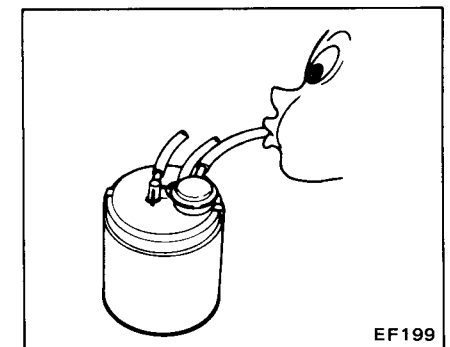

Type-B

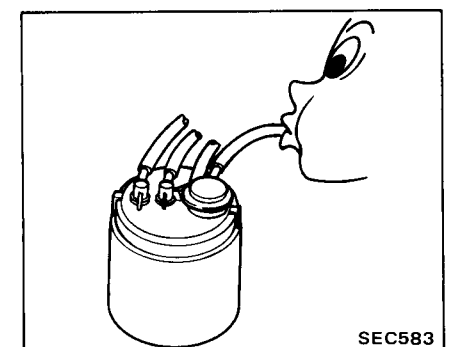

2. If there is a leak, remove top cover from purge control valve and check for dislocated or cracked diaphragm. If necessary, replace diaphragm kit (which is made up of a retainer, diaphragm and spring).

Type-A

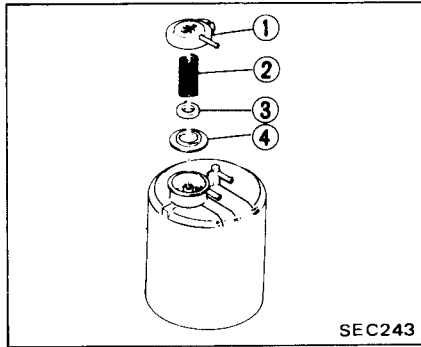

- 1 Cover
- 2 Diaphragm spring
- 3 Retainer
- 4 Diaphragm

Type-B

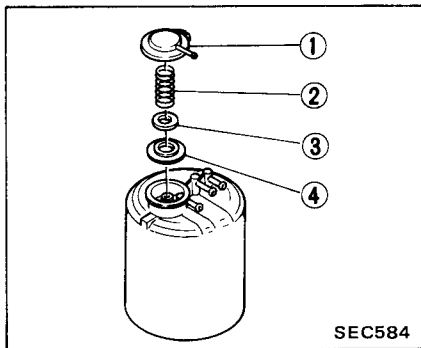

- 1 Cover
- 2 Diaphragm spring
- 3 Retainer
- 4 Diaphragm

Type-A

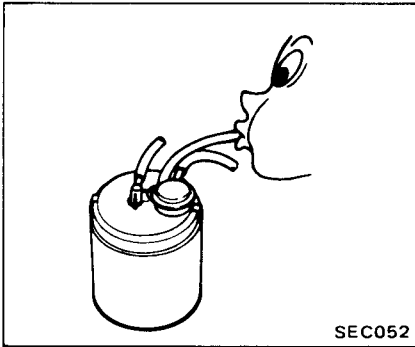

Type-B

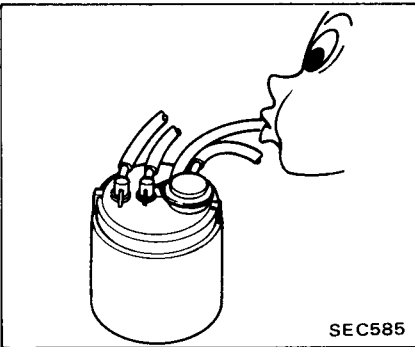

Type-B

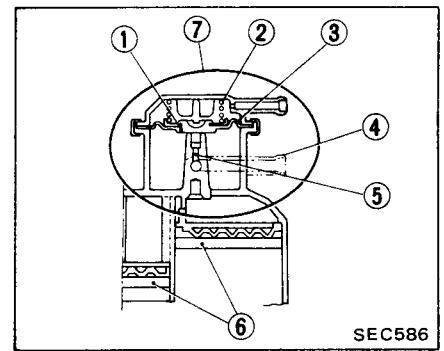

- 1 Retainer
- 2 Spring
- 3 Diaphragm
- 4 Purge line
- 5 Fixed orifice
- 6 Filter
- 7 Purge control valve

FUEL TANK VACUUM RELIEF VALVE

Remove fuel filler cap and see it functions properly.

1. Wipe clean valve housing and have it in your mouth.
2. Inhale air. A slight resistance accompanied by valve indicates that valve is in good mechanical condition. Note also that, by further inhaling air, the resistance should be disappeared with valve clicks.
3. If valve is clogged, or if no resistance is felt, replace cap as an assembled unit.

2. If there is no leak, remove purge control valve and check constant purge orifice for leak. If necessary, blow constant purge orifice.

Type-A

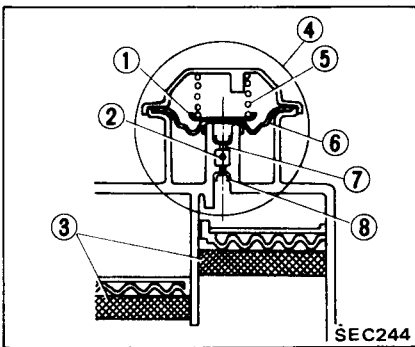

- 1 Retainer
- 2 Purge line
- 3 Filter
- 4 Purge control valve
- 5 Spring
- 6 Diaphragm
- 7 Purge orifice
- 8 Constant purge orifice

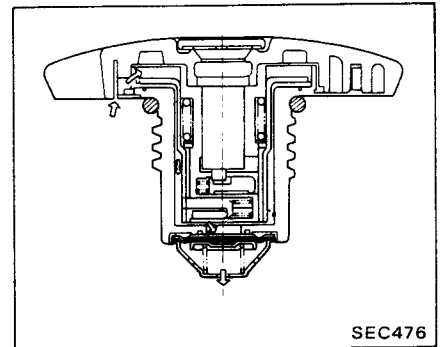

CARBON CANISTER CONSTANT PURGE ORIFICE

Check for constant purge flow, in the intake manifold vacuum line, at constant purge orifice of carbon canister.

To check for purge flow, proceed as follows:

1. Inhale air into the opening of rubber hose running to carbon canister and ensure that there is a leak.

FUEL CHECK VALVE

1. Blow air through connector on fuel tank side.

A considerable resistance should be felt at the mouth and a portion of air flow be directed toward the engine.

2. Blow air through connector on engine side.

Air flow should be smoothly directed toward fuel tank.

3. If fuel check valve is suspected of not being properly functioning in steps 1 and 2 above, replace.

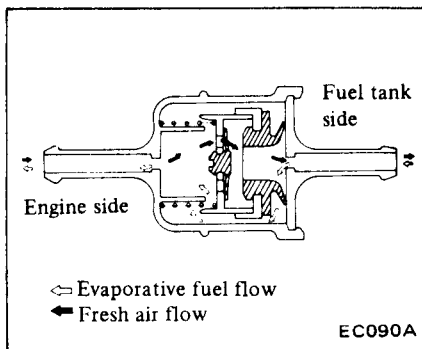

SERVICE DATA AND SPECIFICATIONS (S.D.S.)

GENERAL SPECIFICATIONS

FUEL PUMP

Design voltage	V	12
Cut-off discharge pressure	kPa (kg/cm ² , psi)	294 - 441 (3.0 - 4.5, 43 - 64)
Design current	A	5.1

PRESSURE REGULATOR

Regulated pressure	kPa (kg/cm ² , psi)	250.1 (2.55, 36.3)
--------------------	--------------------------------	--------------------

COLD START VALVE

Injection quantity	mL (US fl oz, Imp fl oz)	135 (4.6, 4.8)
Design voltage	V	12

THERMOTIME SWITCH

Design voltage	V	12
Switch-over temperature	°C (°F)	19.5 (67)
Switch-over time [at -20°C (-4°F), 10V] sec.		9

AIR FLOW METER

Design voltage	V	12
----------------	---	----

AIR REGULATOR

Design voltage	V	12
Air flow quantity [at 20°C (68°F)]	m ³ (cu ft)/hr	27.5 (971)

CONTROL UNIT

Design voltage	V	12
----------------	---	----

INSPECTION AND ADJUSTMENT

FUEL PRESSURE

Unit: kPa (kg/cm², psi)

Measuring point: between fuel filter and fuel pipe	
At idling	Approximately 206 (2.1, 30)
The moment accelerator pedal is fully depressed	Approximately 255 (2.6, 37)

FUEL INJECTOR

Coil resistance	Ω	2.35
-----------------	---	------

THERMOTIME SWITCH

Cooling water temperature below 14°C (57°F)	ON
14 - 25°C (57 - 77°F)	ON or OFF
above 25°C (77°F)	OFF
Coil resistance	Ω 40 - 70

AIR FLOW METER

E.F.I. models

Unit: Ω

Potentiometer resistance between terminals ③③ and ③④	100 - 400
between terminals ③④ and ③⑤	200 - 500
between terminals ③② and ③④	Except 0 and ∞

E.C.C.S. models

Unit: Ω

Potentiometer resistance between terminals ③③ and ②⑥	Approx. 280 - 400
between terminals ③③ and ③①	Except 0 and ∞

AIR TEMPERATURE SENSOR

Unit: $k\Omega$

Thermistor resistance at -10°C (14°F)	7.0 - 11.4
at 20°C (68°F)	2.1 - 2.9
at 50°C (122°F)	0.68 - 1.00

THROTTLE VALVE SWITCH

E.F.I. models

Engine speed when idle switch is changed from "ON" to "OFF"	rpm	Approximately 900
---	-----	-------------------

E.C.C.S. models

Engine speed when idle switch is changed from "ON" to "OFF"	rpm	Approximately 750
---	-----	-------------------

CYLINDER HEAD TEMPERATURE SENSOR

Unit: $k\Omega$

Thermistor resistance at -10°C (14°F)	7.0 - 11.4
at 20°C (68°F)	2.1 - 2.9
at 50°C (122°F)	0.68 - 1.0

WATER TEMPERATURE SENSOR

Unit: $k\Omega$

Thermistor resistance at -10°C (14°F)	7.0 - 11.4
at 20°C (68°F)	2.1 - 2.9
at 50°C (122°F)	0.68 - 1.0

V.C.M. SOLENOID VALVE

Coil resistance	Ω	40
-----------------	----------	----

WATER TEMPERATURE SENSING SWITCH (For auxiliary cooling fan)

Cooling water temperature		OFF
E.F.I.	below about 102°C (216°F)	
E.C.C.S.	below about 100°C (212°F)	ON
E.F.I.	above about 102°C (216°F)	
E.C.C.S.	above about 100°C (212°F)	

FAN MOTOR TIMER UNIT (For auxiliary cooling fan)

Operating period minutes	about 17
--------------------------	----------

TIGHTENING TORQUE

Unit	N·m	kg·m	ft·lb
Throttle chamber securing screw	15 - 20	1.5 - 2.0	11 - 14
Exhaust gas sensor	39 - 49	4.0 - 5.0	29 - 36
Fuel hose clamp	1.0 - 1.5	0.10 - 0.15	0.7 - 1.1

Fuel hose clamping position

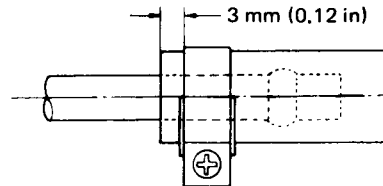

EF336A

E.G.R. tube securing nut	34 - 44	3.5 - 4.5	25 - 33
Thermal vacuum valve	Less than 22	Less than 2.2	Less than 16
Catalytic converter bolt	31 - 42	3.2 - 4.3	23 - 31
Exhaust gas sensor	39 - 49	4.0 - 5.0	29 - 36