

# BRAKE SYSTEM

## SECTION BR

### CONTENTS

<b>SERVICE BRAKE</b> .....	BR- 2	BLEEDING HYDRAULIC SYSTEM .....	BR-14
BRAKE PEDAL .....	BR- 2	<b>PARKING BRAKE</b> .....	BR-15
MASTER CYLINDER .....	BR- 2	PARKING BRAKE .....	BR-15
BRAKE FLUID LEVEL GAUGE .....	BR- 4	<b>SERVICE DATA AND</b>	
BRAKE LINE .....	BR- 4	<b>SPECIFICATIONS (S.D.S.)</b> .....	BR-16
NP-VALVE .....	BR- 4	GENERAL SPECIFICATIONS .....	BR-16
FRONT DISC BRAKE .....	BR- 5	INSPECTION AND ADJUSTMENT .....	BR-16
FRONT DISC ROTOR .....	BR- 7	TIGHTENING TORQUE .....	BR-17
REAR DISC BRAKE –CL14H– .....	BR- 9	<b>TROUBLE DIAGNOSES AND</b>	
REAR DISC ROTOR .....	BR-12	<b>CORRECTIONS</b> .....	BR-18
BRAKE BOOSTER .....	BR-13	<b>SPECIAL SERVICE TOOL</b> .....	BR-20

Refer to Section MA (Brake System) for:

- CHECKING FOOT BRAKE
- CHECKING PARKING BRAKE

# SERVICE BRAKE

## BRAKE PEDAL

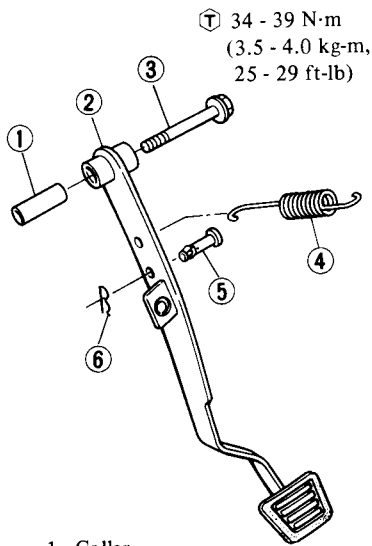

- 1 Collar
- 2 Brake pedal
- 3 Fulcrum bolt
- 4 Return spring
- 5 Clevis pin
- 6 Snap pin

SBR242

### REMOVAL

1. Remove instrument lower cover and floor assist nozzle.
2. Remove snap pin and clevis pin and then separate Brake Booster operating rod from pedal.
3. Remove fulcrum bolt.

### INSPECTION

Check brake pedal for the following items, servicing as necessary.

1. Check pedal bushing for wear, deformation or damage.
2. Check for bent brake pedal.
3. Check for fatigued return spring.

### INSTALLATION

Install brake pedal in reverse order of removal, paying attention to the following:

- Ⓣ : Fulcrum bolt  
 34 - 39 N·m  
 (3.5 - 4.0 kg-m,  
 25 - 29 ft-lb)

1. Apply sufficient amount of recommended multi-purpose grease to sliding contact surface and hook of return spring.

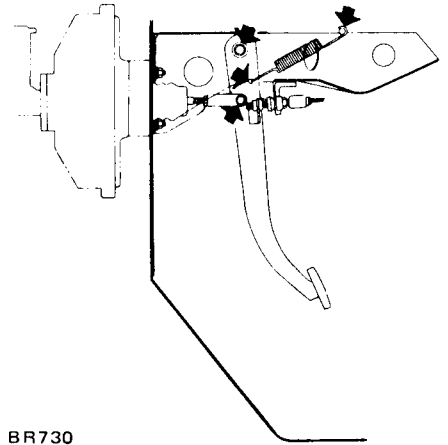

BR730

2. Adjust brake pedal, referring to Section MA.

## MASTER CYLINDER

NABCO make

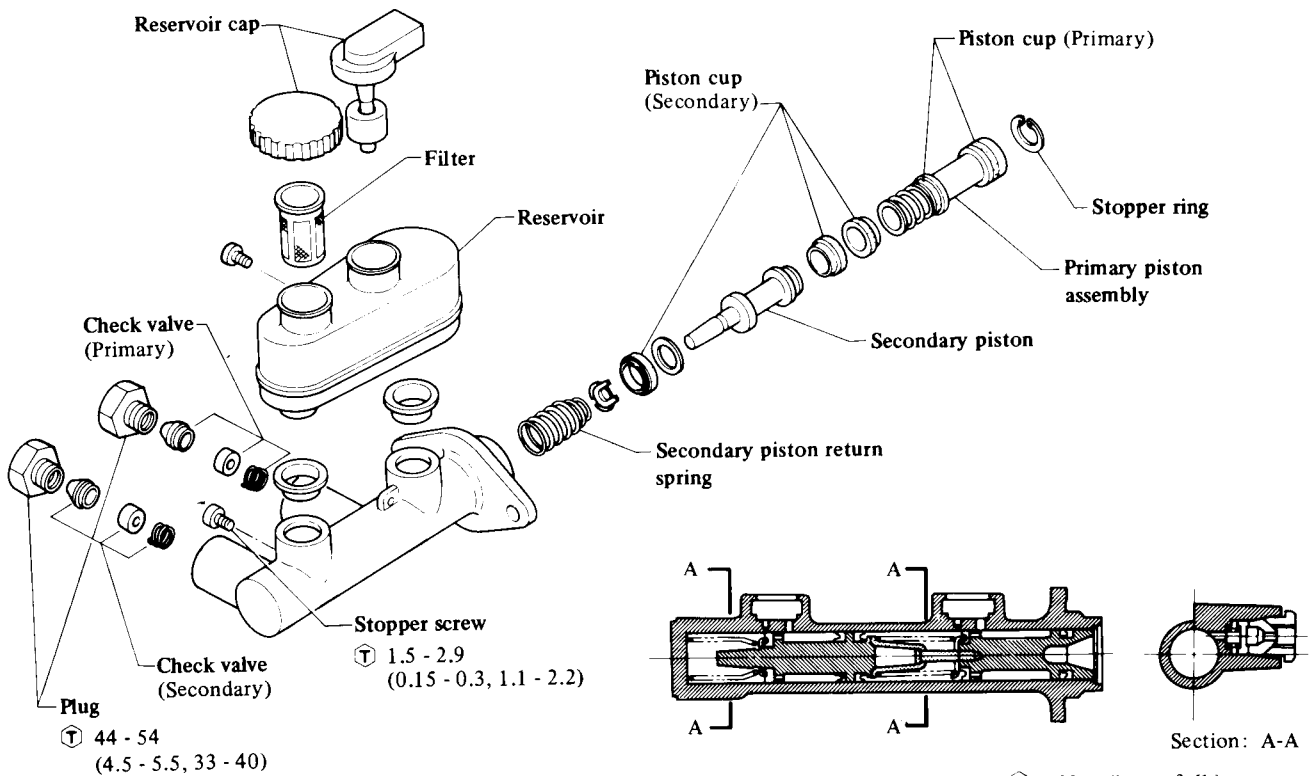

Ⓣ : N·m (kg-m, ft-lb)

SBR390

# Brake System

TOKICO make

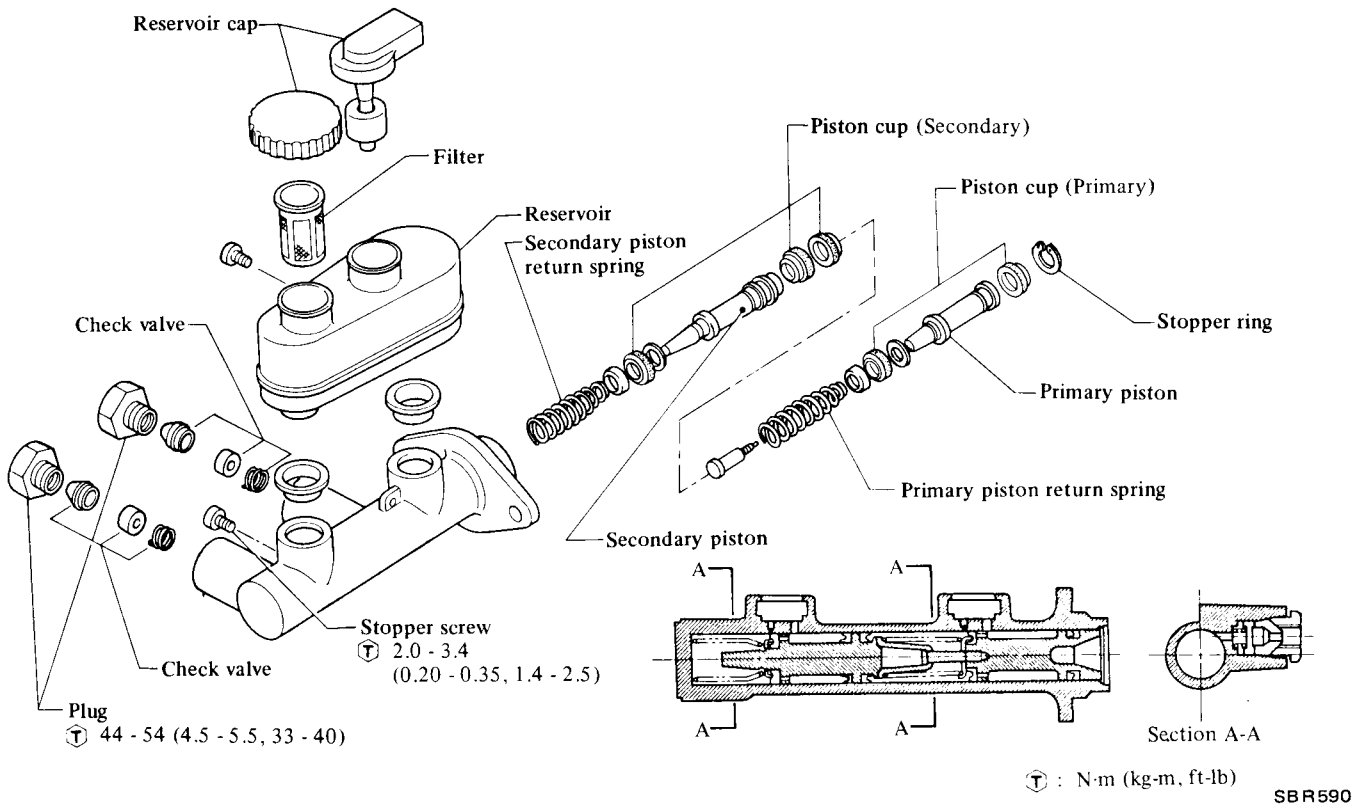

## DISASSEMBLY

There is no interchangeability of repair kits or component parts between NABCO and TOKICO makes.

When replacing the repair kit or component parts, ascertain the brand of the brake master cylinder body. Be sure to use parts of the same make as the former ones.

1. Pry off stopper ring.

Primary piston assembly can then be taken out.

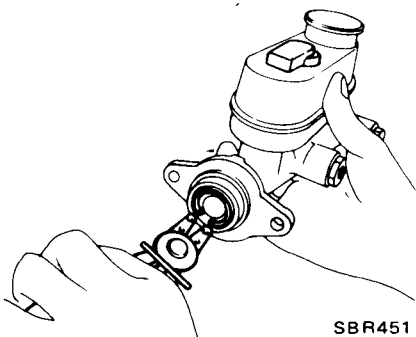

2. Remove stopper screw.  
Secondary piston assembly can then be taken out.

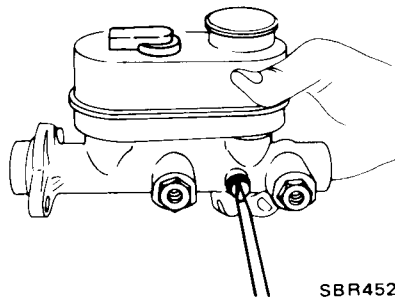

3. Disassemble piston assembly. Do not disassemble primary piston assembly of NABCO make.

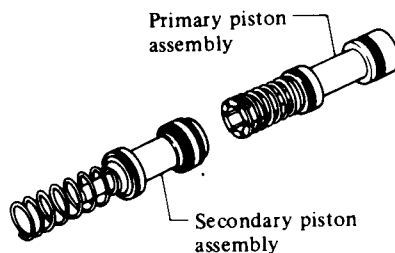

4. Remove piston cups and discard them.

TOKICO make

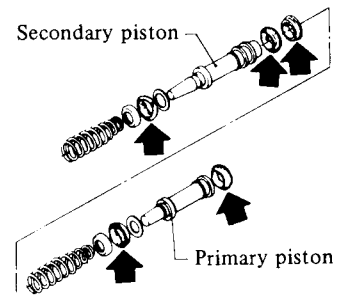

NABCO make

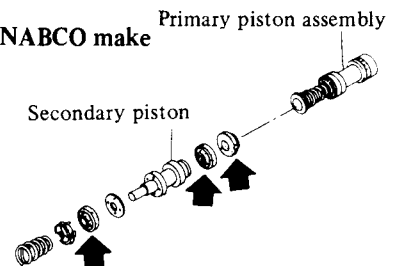

5. Unscrew plugs for disassembling check valve.

## INSPECTION

1. Clean all parts in a brake fluid.
2. Check the parts for evidence of abnormal wear or damage.
3. Check piston-to-cylinder clearance.

**Piston-to-cylinder clearance:**  
Less than 0.15 mm (0.0059 in)

## ASSEMBLY

- a. Replace piston cups and packing with new ones.
- b. Apply brake fluid or rubber grease to sliding contact surface of parts to facilitate assembly of master cylinder.
- c. Use care to install the proper check valves on primary side and secondary side.

Ⓣ : Check valve plug  
44 - 54 N·m  
(4.5 - 5.5 kg·m,  
33 - 40 ft·lb)

## BRAKE FLUID LEVEL GAUGE

### INSPECTION

1. Disengage hand brake control lever.
2. Raise cap and make sure that brake warning lamp goes on when float comes into contact with stopper.

## BRAKE LINE

### REMOVAL

1. Remove flare nuts on both ends, and remove retainers and clips.

### CAUTION:

When removing brake tubes and hoses, use suitable tube wrench. Never use open end or adjustable wrench.

2. To remove brake hose, first remove flare nut securing brake tube to brake hose and withdraw lock spring. End of hose can then be removed from bracket. Next remove brake hose. Do not twist brake hose.

### INSPECTION

Check brake lines (tubes and hoses) for evidence of cracks, deterioration or other damage. Replace any faulty parts.

If leakage occurs at end around joints, re-tighten or, if necessary, replace faulty parts.

### INSTALLATION

Pay particular attention to following instructions when installing brake lines.

1. Leave a sufficient space between brake lines and adjacent parts so that brake lines are completely free from vibration during driving.
2. Be careful not to warp or twist.
3. When installing brake tube, keep a certain distance between tube and adjacent parts as follows:

- Tube to rotating parts  
More than 10 mm (0.39 in)
- Tube to other parts  
More than 5 mm (0.20 in)

4. Always fasten brake tubes with mounting clips where necessary.

On rear suspension arm, there are two double clips which should be used to secure brake tubes in manner described below.

Bend short clip straight up. With brake tube on long clip, bend clip up and around tube. Finally, wrap short clip around tube to secure the installation.

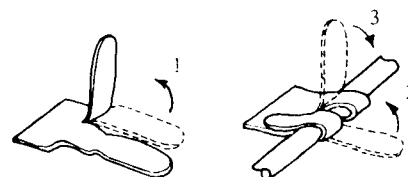

BR141

5. Do not tighten brake line mounting flare nut excessively.

### CAUTION:

When installing brake tubes, use Flare Nut Torque Wrench GG94310000.

Ⓣ : Brake tube flare nut

15 - 18 N·m  
(1.5 - 1.8 kg·m,  
11 - 13 ft·lb)

Brake hose connector

17 - 20 N·m  
(1.7 - 2.0 kg·m,  
12 - 14 ft·lb)

6. Upon completion of installation of brake lines, bleed air out of brake lines.

## NP-VALVE

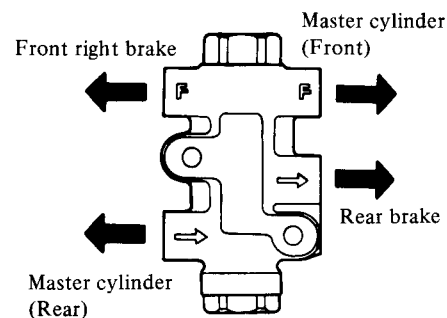

BR163A

## REMOVAL AND INSTALLATION

1. Remove flare nuts.

### CAUTION:

When removing brake tube, use suitable tube wrench. Never use open end or adjustable wrench.

2. Remove NP-valve retaining bolts, and remove NP-valve.

Note: Do not disassemble NP-valve.

3. Installation is in the reverse order of removal.

### CAUTION:

When installing brake tube, use Flare Nut Torque Wrench GG94310000.

Ⓣ : Flared nut

15 - 18 N·m  
(1.5 - 1.8 kg·m,  
11 - 13 ft·lb)

NP-valve attaching bolt

6 - 7 N·m  
(0.6 - 0.7 kg·m,  
4.3 - 5.1 ft·lb)

## FRONT DISC BRAKE

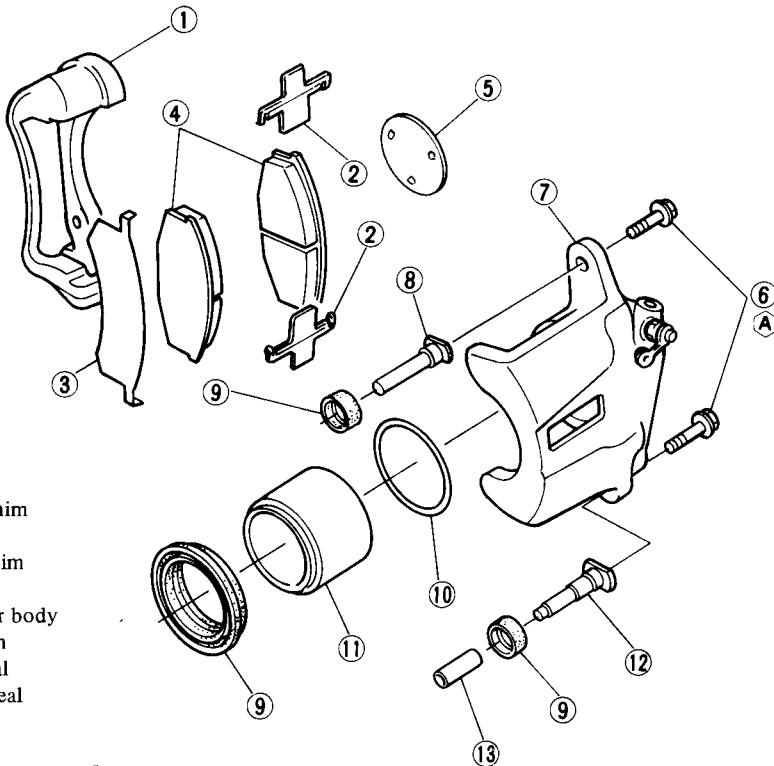

- 1 Torque member
- 2 Pad
- 3 Outer shim
- 4 Pad
- 5 Inner shim
- 6 Pin bolt
- 7 Cylinder body
- 8 Main pin
- 9 Dust seal
- 10 Piston seal
- 11 Piston
- 12 Sub pin
- 13 Rubber seal

Tightening torque N·m (kg·m, ft·lb)

Ⓐ : 22 - 31 (2.2 - 3.2, 16 - 23)

BR164A

## PAD REPLACEMENT

### Removal

1. Jack up front of car, and support it on safety stands. Remove wheel.
2. Remove lower pin bolt.

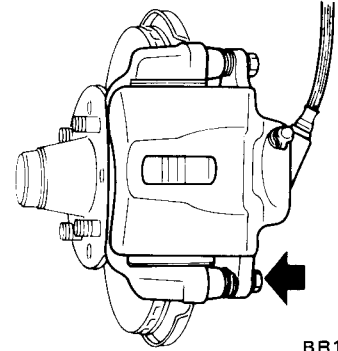

BR165A

3. Open cylinder body upward and remove pad retainer (2), and inner and outer shims (1 & 3).

Note: Do not pull out cylinder body in axial direction (direction of pin guide).

4. Detach pads.

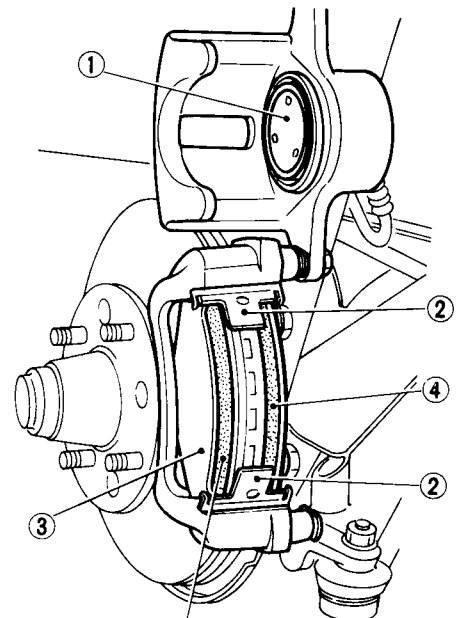

- 1 Inner shim
- 2 Pad retainer
- 3 Outer shim
- 4 Pads

BR166A

### CAUTION:

After removing pads, do not depress brake pedal, or pistons will jump out.

# Brake System

## Inspection

1. When pads are heavily fouled with oil or grease or when pad is deteriorated or deformed, replace it.
2. If pad is worn to less than the specified value, replace.

### Pad wear limit

(Minimum thickness):

2 mm (0.08 in)

Note: Always replace pads in pad kit (four pads).

3. Check rotor, referring to Rotor for inspection.

## Installation

1. Clean piston end and surroundings of pin bolts.

### CAUTION:

Use brake fluid to clean. Never use mineral oil.

Note: Be careful not to get oil on rotor.

2. Install new pad (inner side).

Insert lever into opening in cylinder body as shown below and push piston by catching torque member.

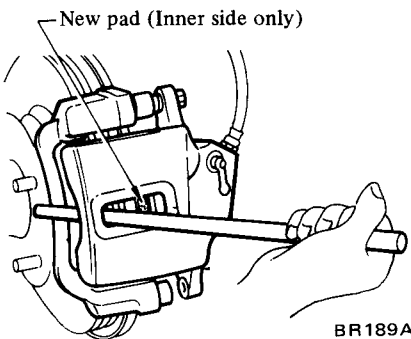

3. Coat the following point with PBC grease or silicone-based grease.

- Torque member-to-pad clearance

Note: Do not grease friction face of pad.

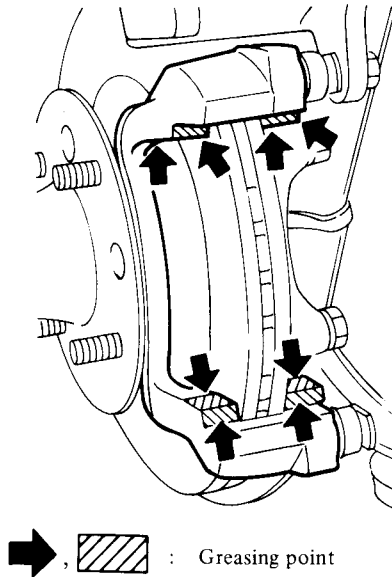

4. Install new pad (outer side), and inner and outer shims.

5. After installing pads, install pad retainer, being careful not to fit it upside down.

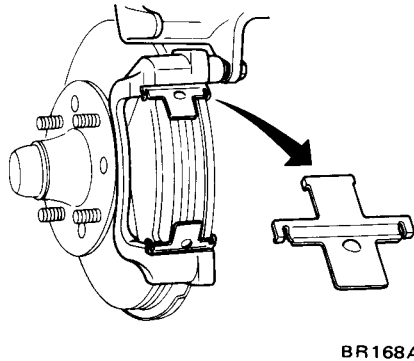

6. Install cylinder body and then tighten lower pin bolt.

Ⓧ : Pin bolt

22 - 31 N·m  
(2.2 - 3.2 kg·m,  
16 - 23 ft·lb)

7. Depress brake pedal several times, and pads will settle into proper position.

8. Install wheels and lower car to ground.

## REMOVAL

1. Jack up front of car, and support it on safety stands. Remove wheel.
2. Remove front brake hose.

### CAUTION:

When removing brake tube, use suitable tube wrench. Never use open-end or adjustable wrench.

Note: Plug up hole in caliper and brake tube so that brake fluid does not flow out.

3. Remove caliper assembly from knuckle spindle.

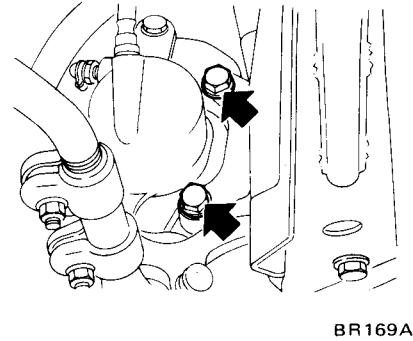

## DISASSEMBLY

1. Drain brake fluid from cylinder body.
2. Wipe off dust and mud from caliper assembly.
3. Remove pin bolts.

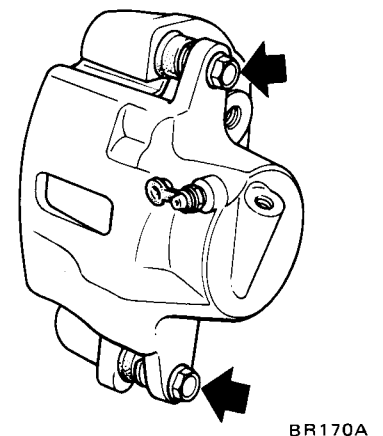

4. Separate cylinder body and torque member.

5. Remove pad retainers and pads.

6. Force out pistons with dust seal from cylinder by feeding compressed air gradually.

# Brake System

**WARNING:**

Gradually increase air pressure so that piston does not pop out.

7. Remove piston seals.

**CAUTION:**

Be careful not to damage seals and cylinder body.

8. If necessary, remove sub pin, main pin and dust seals.

**INSPECTION**

Clean all parts and check as follows:

**CAUTION:**

Use brake fluid to clean. Never use mineral oil.

**Cylinder body**

1. Check inside surface of cylinder for score, rust, wear, damage or presence of foreign substances. If any surface fault is detected, replace cylinder body.
2. Minor damage from rust of foreign substances may be eliminated by polishing surface with a fine emery cloth. If damage is major, cylinder assembly must be replaced.

**Torque member**

Check for wear, cracks or other damage. Replace if any fault is detected.

**Piston**

Check piston for score, rust, wear, damage or presence of foreign substances. Replace if any fault is detected.

**CAUTION:**

Piston sliding surface is plated. Do not polish with emery paper even if rust or foreign matter is stuck on sliding surface.

**Piston seal and dust seal**

Replace piston seal and dust seal at each disassembly.

**Main pin, sub pin and rubber bushing**

Check for wear, cracks or other damage. Replace if any fault is detected.

**ASSEMBLY**

Assemble front brake in reverse order of disassembly, closely observing the following:

1. Install piston seals, taking care not to damage them.
2. Apply brake fluid to sliding portions of piston, inside of cylinder body.
3. With dust seal fitted to piston, insert dust seal into groove in cylinder body and install piston. Then securely fit dust seal.

Note: Apply rubber grease to inside of dust seal.

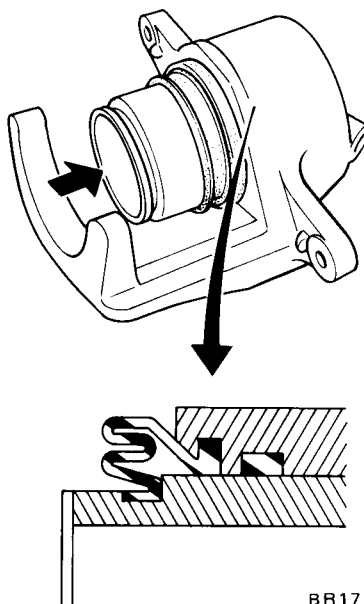

4. Coat the following part with recommended brake grease.

- Torque member-to-pad clearance.
5. Apply a coat of recommended multi-purpose grease to main pin rubber bushing and to sub pin.

6. Tighten pin bolts.

**ⓧ : Pin bolts**

22 - 31 N·m  
(2.2 - 3.2 kg·m,  
16 - 23 ft·lb)

**INSTALLATION**

1. Install caliper assembly without pads and pad retainer to knuckle spindle.

**ⓧ : Caliper mounting bolt**

72 - 97 N·m  
(7.3 - 9.9 kg·m,  
53 - 72 ft·lb)

2. Install pads and pad retainer. Refer to Pad Replacement.
3. Install front brake hose and bleed brake system.

**CAUTION:**

When installing brake tubes, use Flare Nut Torque Wrench GG94310000.

**ⓧ : Brake tube flare nut**

15 - 18 N·m  
(1.5 - 1.8 kg·m,  
11 - 13 ft·lb)

**Air bleeder**

7 - 9 N·m  
(0.7 - 0.9 kg·m,  
5.1 - 6.5 ft·lb)

4. After installing, see if there is no leak by depressing brake pedal several times.

Note: Turn rotor to make sure it does not drag excessively.

**FRONT DISC ROTOR REMOVAL**

Refer to Removal (Section FA).

**INSPECTION**

Check the following items and, if necessary, replace. Checks can be made by removing only wheel.

# Brake System

## 1. Sliding surface

If there are cracks or considerable chips, replace.

## 2. Runout

Adjust wheel bearing correctly. Using a dial gauge, measure runout.

### Runout limit:

**Total indicator reading  
Less than 0.10 mm (0.0039 in)  
at center of rotor pad  
contact surface**

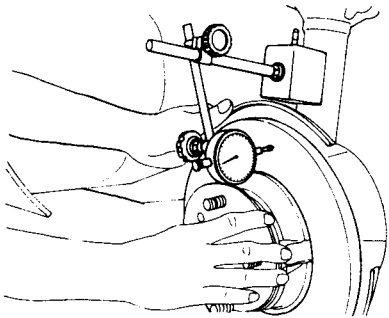

BR025A

## 3. Parallelism

Measure thickness of rotor in circumferential direction, using a micrometer.

### Parallelism:

#### Circumferential direction

**Less than  
0.03 mm (0.0012 in)**

**Note:** As this value increases (wear occurs progressively), vibration corresponding to revolution of tire may often be transmitted to interior of car.

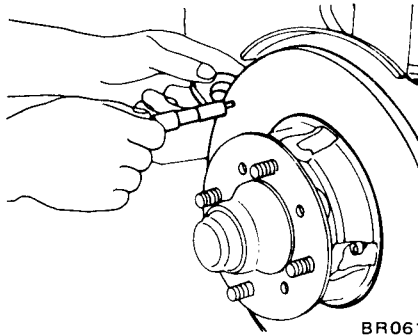

BR061

## 4. Thickness

If rotor thickness is beyond wear limit, replace rotor. When correcting thickness, be sure that the thickness after correction does not exceed the limit.

### Standard thickness:

**20.0 mm (0.787 in)**

### Wear limit (Minimum thickness):

**18.0 mm (0.709 in)**

## INSTALLATION

Install rotor in reverse order of removal. Adjust wheel bearing preload correctly. Refer to Adjustment (Section MA).

### Ⓣ : Rotor to wheel hub

**54 - 74 N·m**

**(5.5 - 7.5 kg-m,**

**40 - 54 ft-lb)**





## PAD REPLACEMENT

### Removal

1. Remove pin bolts.

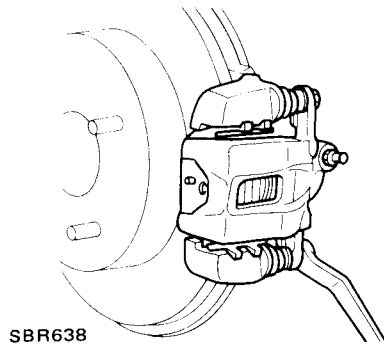

2. Remove pad springs, pads and pad shim.

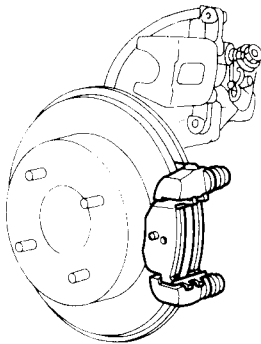

### Installation

1. Clean piston end and area around pin bolts.

**Be careful not to get oil on rotor.**

2. Retract piston into cylinder body by turning it clockwise.

**Be careful not to damage piston boot.**

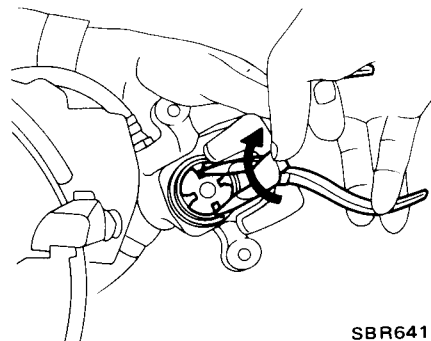

3. Coat the pad contact area on mounting support with PBC grease or silicone-based grease.

4. Install pads, shim and pad springs.

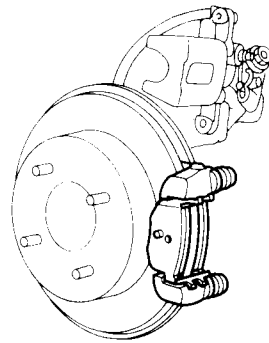

5. Fix cylinder body.

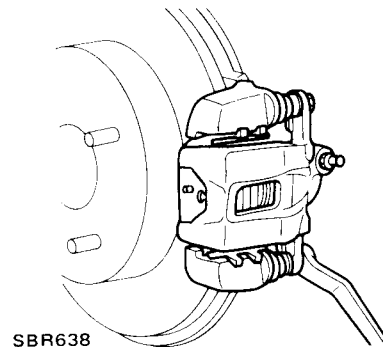

⊕ : 22 - 31 N-m  
(2.2 - 3.2 kg-m, 16 - 23 ft-lb)

⊕ : Caliper fixing bolts

38 - 52 N-m  
(3.9 - 5.3 kg-m,  
28 - 38 ft-lb)

Brake hose connector

17 - 20 N-m  
(1.7 - 2.0 kg-m,  
12 - 14 ft-lb)

## DISASSEMBLY

1. Remove outer spring retainer and pin bolt.

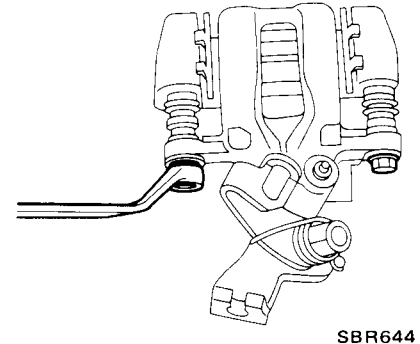

2. Separate cylinder body from torque member.

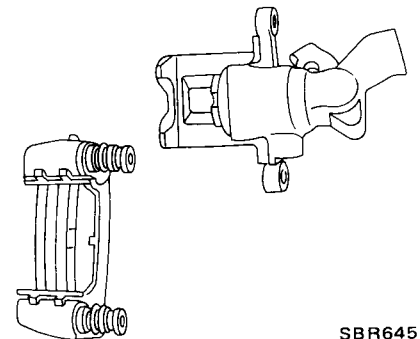

## REMOVAL AND INSTALLATION

Disconnect parking brake cable and brake hose, then remove caliper assembly.

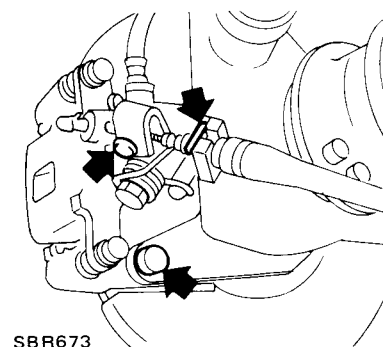

3. Remove piston by turning it counterclockwise with suitable long nose pliers.

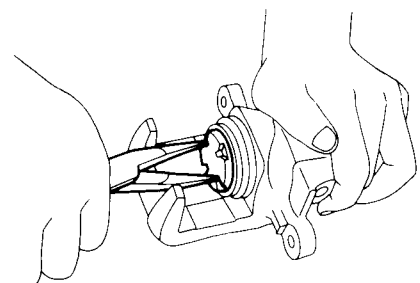

# Brake System

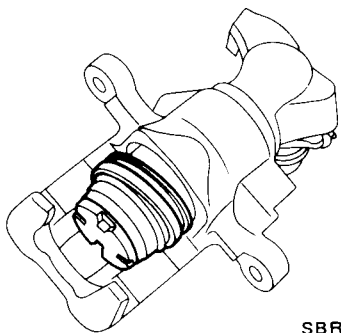

SBR647

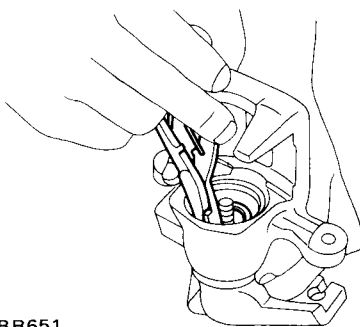

SBR651

6. Remove piston seal.

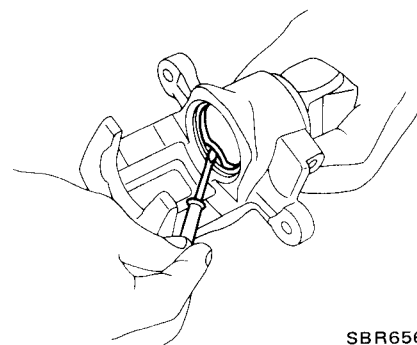

SBR656

4. Disassemble piston as follows.

(1) Pry off ring.

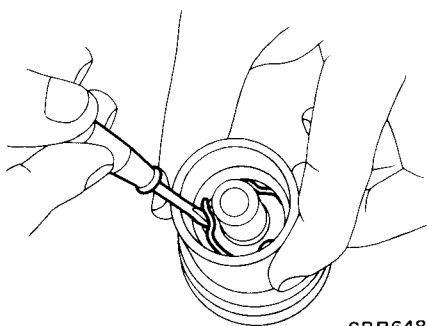

SBR648

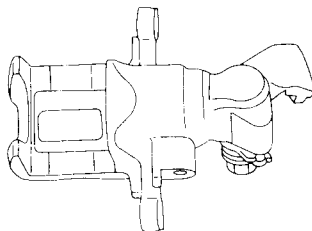

SBR652

(2) Pry off ring B, then remove key plate, push rod and rod.

7. Disassemble lever.

(1) Remove return spring.

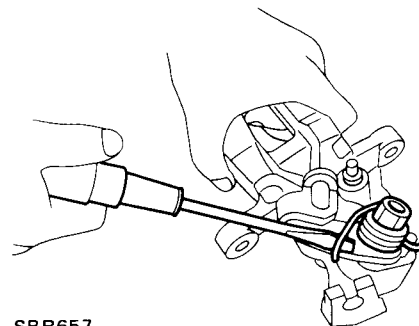

SBR657

(2) Adjust nut, ball bearing, wave washer and spacers can then be removed.

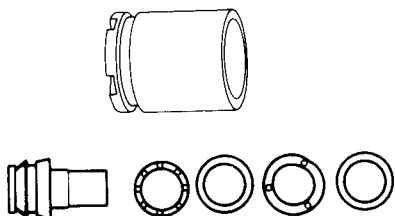

SBR649

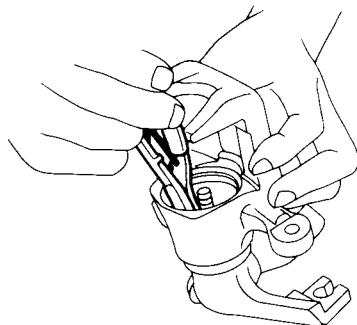

SBR653

(2) Remove nut, spring washer and lever.

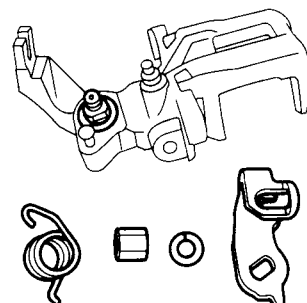

SBR658

(3) Remove cup.

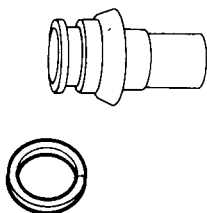

SBR650

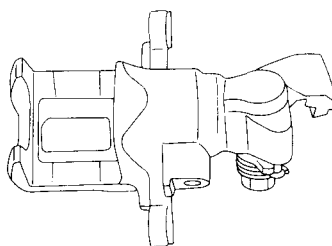

SBR654

(3) Remove adjusting cam and cam boot.

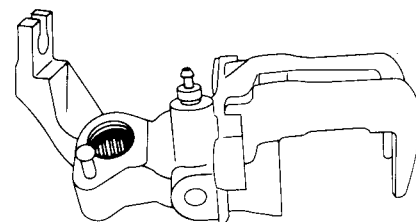

SBR659

5. Disassemble cylinder body.

(1) Pry off ring A with suitable pliers, then remove spring cover, spring and seat.

(3) Remove O-ring.

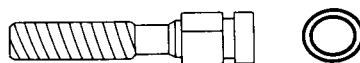

SBR655

# Brake System

8. Remove pin and pin boot as necessary.

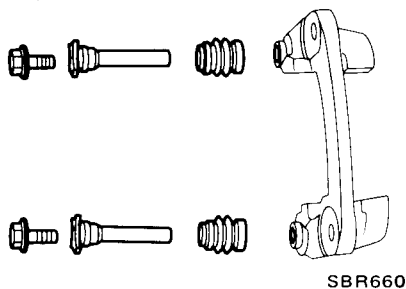

## INSPECTION

Clean all parts and check as follows:

### CAUTION:

Use brake fluid to clean. Never use mineral oil.

## Cylinder body

1. Check inside surface of cylinder for score, rust, wear, damage or presence of foreign substances. If any surface fault is detected, replace cylinder body.
2. Minor damage from rust of foreign substances may be eliminated by polishing surface with a fine emery cloth. If damage is major, cylinder assembly must be replaced.

## Mounting support

Check for wear, cracks or other damage. Replace if any fault is detected.

## Piston

Check piston for score, rust, wear, damage or presence of foreign substances. Replace if any fault is detected.

### CAUTION:

Piston sliding surface is plated. Do not polish with emery paper even if rust or foreign matter is stuck to sliding surface.

## Piston seal and piston boot

Replace piston seal and piston boot at each disassembly.

## Pin and pin boot

Check for wear, cracks or other damage. Replace if any fault is detected.

## Adjust nut cup and push rod O-ring

Replace once they have been disassembled.

## ASSEMBLY

- Before assembling, apply thin coat of rubber grease to the following:

Groove in **push rod** and new **O-ring**  
Strut ends

Groove in **adjust nut** and **cup**  
**Piston seal**

Inside of **boot**

Sliding portions of **piston** and **pins**

- Install cup securely in the specified direction.

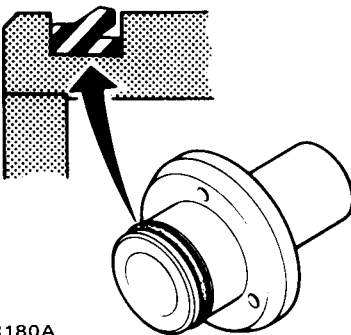

BR180A

- Fit push rod into square hole in key plate. Also fit convex portion of key plate with concave portion of cylinder.

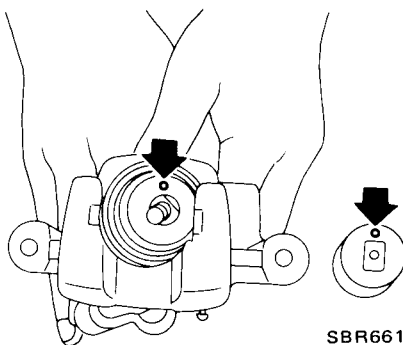

SBR661

- Install ring B with suitable tool.

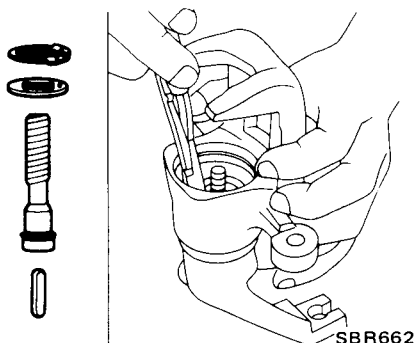

SBR662

- Install seat, spring, spring cover and ring A with suitable press and drift.

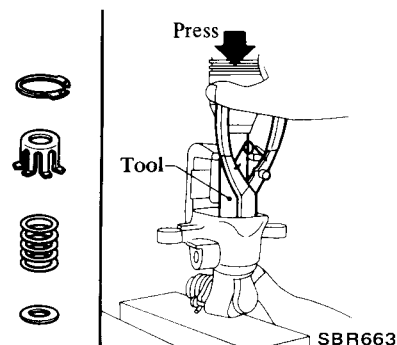

SBR663

## REAR DISC ROTOR

### REMOVAL AND INSTALLATION

Remove caliper. Rotor can then be taken out.

## INSPECTION

1. Sliding surface  
If there are cracks or a considerable number of chips, repair or replace.
2. Runout  
Adjust wheel bearing correctly.  
Measure runout at the center of rotor pad contact surface.

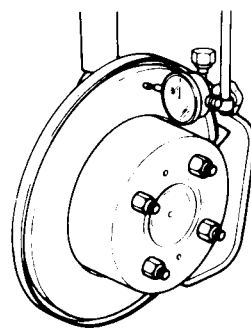

BR104A

**Rotor repair limit:**  
**Maximum runout**  
(Total indicator reading at center of rotor pad contact surface):  
**0.15 mm (0.0059 in)**

3. Thickness

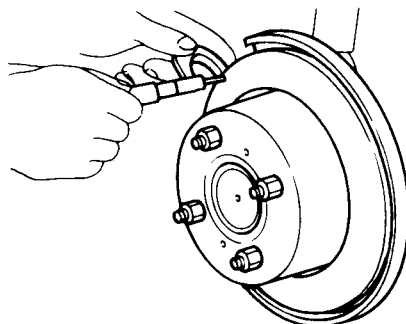

SBR050

**Standard thickness:**  
9.6 mm (0.378 in)  
**Rotor repair limit:**  
**Minimum thickness**  
8.6 mm (0.339 in)

4. Parallelism

**Rotor repair limit:**  
**Maximum parallelism**  
**(Circumferential direction):**  
0.03 mm (0.0012 in)

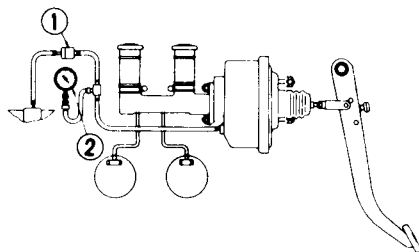

1 Check valve  
2 Vacuum gauge

BR942

2. Start engine and increase engine speed. Stop engine when vacuum gauge indicates 66.7 kPa (500 mmHg, 19.69 inHg).

### Air tight test (No load)

Fifteen seconds after engine is stopped, observe the rate of drop in air pressure registered by vacuum gauge. If vacuum pressure drops more than the specified value, refer to the following chart to determine the cause of failure.

**Maximum vacuum leakage:**  
**3.3 kPa**  
**(25 mmHg, 0.98 inHg)**

## BRAKE BOOSTER

### INSPECTION OF OPERATION

#### Checking vacuum pressure

1. Connect a vacuum gauge, in the line, between check valve and Brake Booster.

### Inspecting check valve

1. Remove clip and disconnect hoses at connections. The check valve can now be removed.

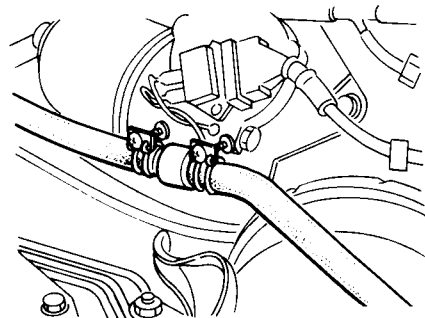

BR183A

2. Using a Brake Booster tester, apply a vacuum pressure of 26.7 kPa (200 mmHg, 7.87 inHg) to the port of check valve on the Brake Booster side. If vacuum pressure drops more than the specified value in 15 seconds, replace check valve with a new one.

**Maximum vacuum leakage of check valve:**  
**1.3 kPa**  
**(10 mmHg, 0.39 inHg)**

3. When vacuum pressure is applied to the Brake Booster side of check valve and valve does not open, replace check valve with a new one.

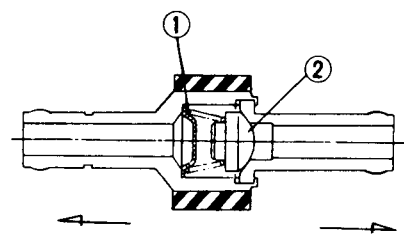

Manifold side

Brake Booster side

1 Spring  
2 Valve

BR953

### Air tight test (Under load)

Fifteen seconds after engine is stopped and brake fully applied, observe the rate of drop in air pressure registered by vacuum gauge. If vacuum

pressure drops more than the specified value, refer to the following chart to determine the cause of failure.

**Maximum vacuum leakage:**  
**3.3 kPa**  
**(25 mmHg, 0.98 inHg)**

Probable cause	Corrective action
1. Air leakage at check valve.	Replace check valve.
2. Damaged diaphragm.	Replace Brake Booster as an assembly.
3. Reaction disc dropped off. (Brake Booster)	
4. Air leakage at poppet assembly seat and valve body.	

4. When installing check valve, be careful to avoid incorrect connections.

### Operating test

1. Connect an oil pressure gauge to brake line, at connection on master cylinder.  
2. Install a pedal force gauge on brake pedal.

3. Start engine, and increase engine speed until a vacuum pressure of 66.7 kPa (500 mmHg, 19.69 inHg) is registered on vacuum pressure gauge. With a steady vacuum pressure of 66.7 kPa (500 mmHg, 19.69 inHg), measure oil pressure with respect to each pedal operating force.

Relationship between oil pressure and pedal operating force is illustrated in following chart. If test results are not as specified in following chart, check Brake Booster for condition in manner described under "Inspection" before removal of this unit.

Also check brake line for evidence of fluid leakage.

**Note:** Determine whether source of problem is in Brake Booster or check valve. Before you reach a final conclusion, always inspect check valve first.

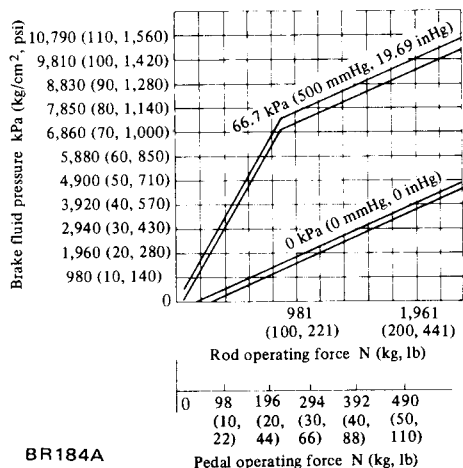

BR184A

## REMOVAL

Remove parts in numerical order enumerated.

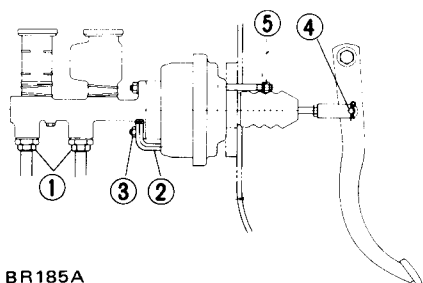

BR185A

## ADJUSTMENT

1. Adjust the length of push rod to the value indicated below. Length adjustment of push rod is made at the tip of push rod.

**Length "A":**  
9.75 - 10.0 mm  
(0.3839 - 0.3937 in)

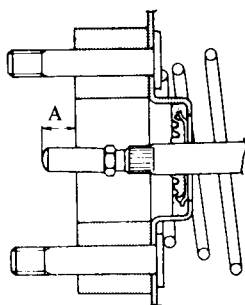

BR109A

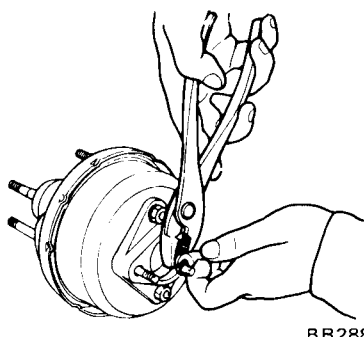

BR288

2. Install clevis. Adjust length of operating rod to specified value.

**Length "B":**  
143 mm (5.63 in)

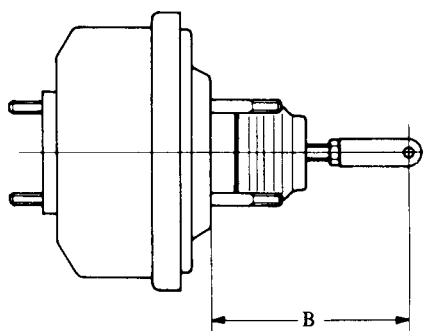

BR110A

## INSTALLATION

Install in the reverse sequence of removal.

**T** : Master cylinder to Brake Booster

8 - 11 N·m  
(0.8 - 1.1 kg·m,  
5.8 - 8.0 ft·lb)

**Brake Booster to body**

8 - 11 N·m  
(0.8 - 1.1 kg·m,  
5.8 - 8.0 ft·lb)

**Note:** After Brake Booster is properly installed in car, conduct an air-tight and operational tests as previously described.

## BLEEDING HYDRAULIC SYSTEM

Hydraulic brake system must be bled whenever any line has been disconnected or air has in some way entered system.

"Spongy" pedal action is an indication that air has entered brake system.

Bleeding hydraulic system deserves much attention as it is an essential element in regular brake servicing.

1. Clean all dirt around master cylinder reservoir, remove cylinder cover and top up reservoir with recommended brake fluid.

**Note:** Do not mix two different brand oils.

2. Thoroughly clean mud or dust from bleeder valve so that outlet hole is free from foreign material. Install a bleeder hose on bleeder valve.

Dip other end of hose into brake fluid bled in a container.

3. Depress brake pedal two or three times and then keep pedal fully depressed.

4. With brake pedal fully depressed, open bleeder valve to exhaust air.

**Note:**

a. Carefully monitor brake fluid level at master cylinder during bleeding operation.

b. Do not re-use brake fluid drained during bleeding operation.

c. Bleed air in the following sequence.

Master cylinder →

Rear wheel → Front wheel

d. Be careful not to splash brake fluid on painted areas.

5. Close bleeder valve quickly as brake pedal is on down stroke.

6. Allow brake pedal to return slowly with bleeder screw closed.

7. Repeat bleeding operations until no air bubbles show in hose.

Note:

a. Brake fluid containing air is white and contains air bubbles.

b. Brake fluid containing no air runs out of bleeder valve in a solid stream free of air bubbles.

8. Repeat steps above on remaining brake line to expel air.

## PARKING BRAKE

### PARKING BRAKE

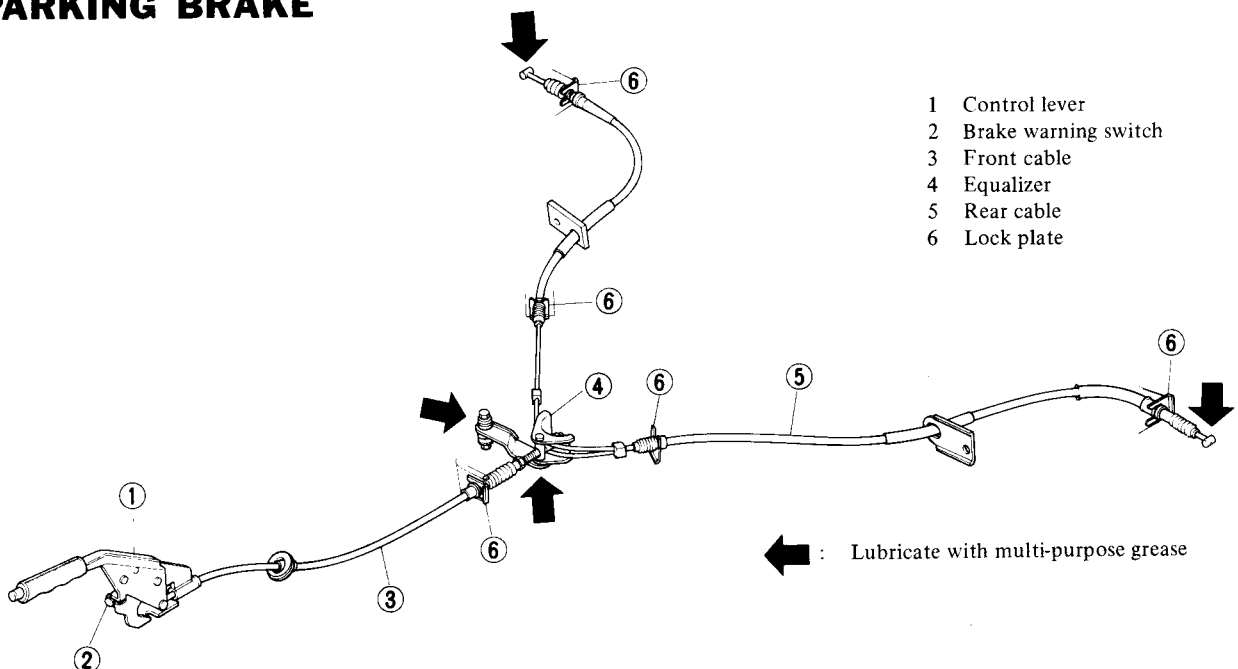

### REMOVAL

#### Control lever and front cable

1. Remove front assistant's seat.
2. Disconnect terminal from parking brake warning switch.
3. Remove bolts securing parking brake control lever to floor.

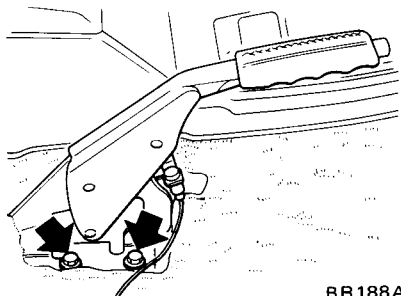

4. Remove lock plate, adjusting nut and lock nut.
5. Pull front cable out into driver's compartment and remove it together with control assembly.

### CAUTION:

**Be careful not to deform or damage control lever.**

Note: Front cable, clevis pin and cotter pin are available as service parts.

### Rear cable

1. Disconnect rear cable at equalizer.
2. Remove cable lock plate from rear suspension and rear disc brake.
3. Remove clevis pin and clevis from rear disc brake.
4. Disconnect rear cable from suspension arm and then remove rear cable.

### INSPECTION

1. Check control lever for wear or other damage. Replace if necessary.

2. Check wires for discontinuity or deterioration. Replace if necessary.

3. Replace malfunctioning warning light or switch.

4. Check parts at each connection and, if found deformed or damaged, replace.

### INSTALLATION

Install parking brake assembly following the reverse procedure of removal. Closely observing the following items:

1. When installing, apply a coating of grease to sliding contact surfaces.
2. Upon completion of installation of parking brake assembly, adjust the entire system as described in Section MA.

3. Make sure that adjacent parts do not interfere with cable.

Do not apply an undue stress to cable.

# SERVICE DATA AND SPECIFICATIONS (S.D.S.)

## GENERAL SPECIFICATIONS

### SERVICE BRAKE

Unit: mm (in)

	Front	Rear
Type	Disc-CL28V	Disc-CL14H
Pad dimension Width x thickness x length	49 x 11 x 118 (1.93 x 0.43 x 4.65)	40 x 8 x 75 (1.57 x 0.31 x 2.95)
Rotor outer diameter	252 (9.92)	258 (10.16)
Caliper inner diameter	60.6 (2.386)	42.8 (1.685)

Master cylinder inner diameter mm (in)	23.81 (15/16)
Brake Booster Type	M90
Diaphragm diameter mm (in)	228.6 (9)
NP-valve Split point kPa (kg/cm <sup>2</sup> , psi)	3,923 (40, 569)
Reducing ratio	0.4

## INSPECTION AND ADJUSTMENT

### BRAKE PEDAL

Unit: mm (in)

	M/T	A/T
Pedal play "a"	1 - 5 (0.04 - 0.20)	
Depressed height "d"	More than 80 (3.15)	More than 90 (3.54)
Pedal height "h"	181 - 187 (7.13 - 7.36)	190 - 196 (7.48 - 7.72)
Full stroke "s"	125 (4.92)	134 (5.28)

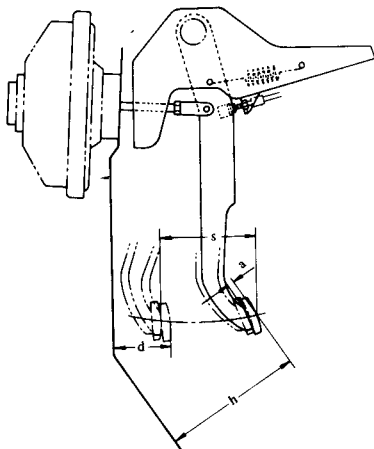

### PARKING BRAKE

Pulling force	N (kg, lb)	265 (27, 60)
Stroke	mm (in)	86 - 109 (3.39 - 4.29)
Number of notches		4 - 6

### MASTER CYLINDER

Allowable clearance between cylinder and piston mm (in)	Less than 0.15 (0.0059)
--	-------------------------

### BRAKE BOOSTER

Maximum vacuum leakage (15 seconds after engine is stopped) kPa (mmHg, inHg)	3.3 (25, 0.98)
Push rod length "A" mm (in)	9.75 - 10.0 (0.3839 - 0.3937)
Operating rod length "B" mm (in)	143 (5.63)

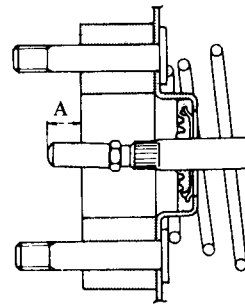

BR109A

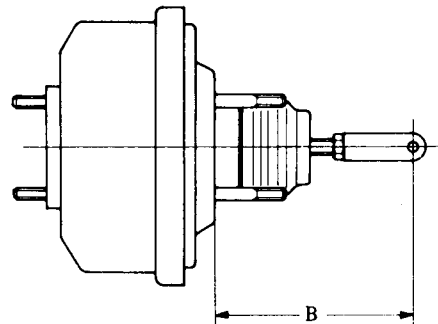

BR947



# Brake System

## CHECK VALVE

Maximum vacuum leakage [15 seconds after 26.7 kPa (200 mmHg, 7.87 inHg) pressure is applied] kPa (mmHg, inHg)	1.3 (10, 0.39)
--	----------------

## DISC BRAKE

Unit: mm (in)

Item	Front	Rear
	CL28V	CL14H
Pad wear limit (Minimum thickness)	2 (0.08)	
Rotor repair limit Maximum runout	0.10 (0.0039)	0.15 (0.0059)
Maximum parallelism circumferential direction	0.03 (0.0012)	
Minimum thickness	18.0 (0.709)	8.6 (0.339)

## TIGHTENING TORQUE

Unit	N·m	kg·m	ft·lb	
Master cylinder to Brake Booster	8 - 11	0.8 - 1.1	5.8 - 8.0	
Brake tube flare nut	15 - 18	1.5 - 1.8	11 - 13	
Brake hose connector	17 - 20	1.7 - 2.0	12 - 14	
Air bleeder valve	7 - 9	0.7 - 0.9	5.1 - 6.5	
Connector mounting bolt	6 mm dia. bolt	5 - 7	0.5 - 0.7	3.6 - 5.1
	8 mm dia. bolt	8 - 11	0.8 - 1.1	5.8 - 8.0
NP-valve	6 - 7	0.6 - 0.7	4.3 - 5.1	
Fulcrum bolt of brake pedal	34 - 39	3.5 - 4.0	25 - 29	
Brake warning lamp switch lock nut	12 - 15	1.2 - 1.5	9 - 11	
Caliper fixing bolt	Front	72 - 97	7.3 - 9.9	53 - 72
	Rear	38 - 52	3.9 - 5.3	28 - 38
Front disc rotor fixing bolt	54 - 74	5.5 - 7.5	40 - 54	
Front brake baffle plate fixing bolts	3.1 - 4.3	0.32 - 0.44	2.3 - 3.2	
Rear disc caliper pin bolt	22 - 31	2.2 - 3.2	16 - 23	
Rear brake baffle plate fixing bolts	3.1 - 4.3	0.32 - 0.44	2.3 - 3.2	
Brake booster				
Brake booster to body	8 - 11	0.8 - 1.1	5.8 - 8.0	
Operating rod lock nut	16 - 22	1.6 - 2.2	12 - 16	
Flange to shell cover	8 - 11	0.8 - 1.1	5.8 - 8.0	
Push rod adjusting nut	16 - 22	1.6 - 2.2	12 - 16	

## TROUBLE DIAGNOSES AND CORRECTIONS

Condition	Probable cause	Corrective action
Excessive pedal travel	<p>Low brake fluid level or empty master cylinder reservoir.</p> <p>Leakage in master cylinder.</p> <p>Deteriorated check valve.</p> <p>Air in system.</p> <p>Faulty brake adjustment.</p> <p>Excessive lateral play on disc caused by loose or worn wheel bearings or steering parts.</p>	<p>Fill and bleed as necessary. Test for source of leakage by examining all lines, connections and wheel cylinder.</p> <p>Overhaul master cylinder.</p> <p>Replace check valve and bleed system.</p> <p>Bleed system.</p> <p>Adjust pad-to-rotor clearance. Inspect auto-adjuster operation.</p> <p>Replace or adjust faulty parts.</p>
Spongy pedal	<p>Low fluid level in master cylinder.</p> <p>Air in system.</p> <p>Faulty brake adjustment.</p> <p>Reservoir filler cap vent hole clogged.</p> <p>Swollen hose due to deterioration or use of poor quality hose.</p> <p>Distorted brake shoes, or excessively worn or cracked brake drum.</p> <p>Soft or swollen caliper seals.</p> <p>Use of a brake fluid with too low boiling point.</p>	<p>Top with fluid and inspect for leakage.</p> <p>Correct as necessary.</p> <p>Adjust pad-to-rotor clearance. Inspect auto-adjuster operation.</p> <p>Clean and bleed system.</p> <p>Replace hose and bleed system.</p> <p>Replace faulty parts.</p> <p>Drain hydraulic system, flush with alcohol and replace all seals.</p> <p>Replace with specified brake fluid and bleed system.</p>
Poor braking effect	<p>Fluid leakage in brake lines.</p> <p>Low brake fluid level or empty master cylinder reservoir.</p> <p>Air in brake lines.</p> <p>Grease, oil, mud or water on pads.</p> <p>Deterioration of pads.</p> <p>Local fit of pads.</p> <p>Pads excessively worn.</p> <p>Master cylinder or caliper assembly in poor condition.</p> <p>Frozen or seized caliper pistons on disc brakes.</p> <p>Binding mechanical linkage at brake pedal.</p>	<p>Check master cylinder, piping and caliper for leaks, and repair.</p> <p>Fill and bleed as necessary.</p> <p>Bleed system.</p> <p>Clean brake mechanism and check for cause of problem. Replace pads.</p> <p>Replace.</p> <p>Shave or replace.</p> <p>Replace.</p> <p>Repair or replace.</p> <p>Disassemble caliper and free up as required.</p> <p>Free up as required.</p>

## Brake System

Condition	Probable cause	Corrective action
Unbalanced brakes	<p>Improper tire inflation.</p> <p>Improper auto adjustment of pad-to-rotor clearance.</p> <p>Grease, oil, mud or water on pads.</p> <p>Mud in rotor.</p> <p>Deterioration of pads.</p> <p>Excessive wear of pads.</p> <p>Caliper cylinder in poor condition.</p> <p>Looseness of caliper assembly securing bolts.</p> <p>Scored or out-of-round rotor.</p> <p>Incorrect adjustment of wheel bearings.</p> <p>Incorrect adjustment of wheel alignment.</p>	<p>Inflate to correct pressure.</p> <p>Readjust.</p> <p>Clean brake mechanism and check for cause of problem. Replace pads.</p> <p>Clean.</p> <p>Replace.</p> <p>Replace.</p> <p>Repair or replace.</p> <p>Fasten or replace.</p> <p>Recondition or replace rotor as required. Check for improper pad contact with rotor and grind pad if necessary.</p> <p>Adjust or replace.</p> <p>Adjust.</p>
Brakes fade	<p>Brake fluid has too low boiling point.</p> <p>Use of improper pads.</p> <p>Brake rotor is out-of-round.</p> <p>Hydraulic connections, master cylinder and caliper cylinders are corroded or damaged.</p> <p>Bleed screw is open.</p>	<p>Drain and fill system with approved fluid.</p> <p>Replace.</p> <p>Repair or replace as necessary.</p> <p>Repair as necessary.</p> <p>Close screw and bleed system.</p>
Brakes drag	<p>Pedal linkage is binding or push rod adjustment is too long.</p> <p>Master cylinder compensator port is obstructed.</p> <p>Seized master cylinder piston.</p> <p>Poor pad condition.</p> <p>Poor caliper cylinder condition.</p> <p>Deformation of piston cups.</p> <p>Poor condition of caliper because of faulty piston seals.</p> <p>Excessive runout of rotor.</p> <p>Hand brake will not return.</p> <p>Clogged master cylinder return port.</p> <p>Clogged brake lines.</p> <p>Incorrect adjustment of wheel bearings.</p> <p>Improper pad-to-rotor clearance.</p> <p>No free travel in brake pedal return.</p>	<p>Lubricate linkage, check pedal return spring for condition and adjust push rod as necessary.</p> <p>Blow out foreign matter with compressed air.</p> <p>Disassemble master cylinder and replace piston. Bleed system.</p> <p>Clean and repair.</p> <p>Repair or replace.</p> <p>Replace.</p> <p>Replace piston seals.</p> <p>Turn rotor on lathe or replace.</p> <p>Check and repair.</p> <p>Clean.</p> <p>Check and clean.</p> <p>Adjust or repair.</p> <p>Adjust.</p> <p>Adjust pedal height.</p>

## Brake System

Condition	Probable cause	Corrective action
Brake chatters	Groove or out-of round rotor. Loose or bent support plate.  Distorted pads. Grease or brake fluid on pads.	Grind or replace as required. Tighten support plate bolts to specified torque, or replace plate. Replace as necessary. Replace pads.
Brake squeals	Dirty or scored rotor.  Bent support plate. Glazed or contaminated pads.	Blow out assembly with compressed air or refinish rotor. Replace faulty unit. Grind pad to eliminate glaze. If it doesn't, replace pad.
Pedal pulsates	Lateral runout of brake rotor is excessive.  Excessive variation in thickness of brake rotor surfaces.	Check with dial indicator, turning disc by hand. If runout exceeds specifications, replace disc. Measure around disc face with micrometer. Replace disc as required.
Rear lock (under light brake pedal force)	Improper tire pressures. Excessive wear of tires. Faulty NP-valve.	Check and adjust. Check and replace. Replace.
Rear lock (under heavy brake pedal force)	Improper tire pressures. Excessive wear of tires. Poor front braking effect. <ul style="list-style-type: none"> <li>● Grease oil, mud or water on pads.</li> <li>● Excessive wear pads.</li> <li>● Local fit pads.</li> <li>● Master cylinder or caliper cylinder in poor condition.</li> </ul>	Check and adjust. Check and replace.  Clean or replace. Replace. Shave or replace. Repair or replace.

## SPECIAL SERVICE TOOL

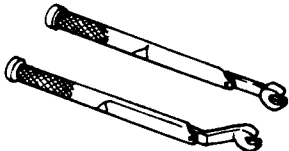
Tool number & tool name	Kent-Moore No.	Tool number & tool name	Kent-Moore No.
	Reference page		Reference page
GG94310000 Flare nut torque wrench	—		
	Page BR-4 Page BR-5 Page BR-7 Page BR-12		